

# Household and similar electrical appliances Safety —

Part 1: General requirements

<http://www.china-gauges.com>

ICS 13.120; 97.030

## National foreword

This British Standard is the UK implementation of EN 60335-1:2002+A2:2006, incorporating A11:2004 and A12:2006, and corrigendum January 2007. It is derived from IEC 60335-1:2001 consolidated with amendments 1:2004 and 2:2006 and corrigenda January 2002 and December 2005. It supersedes BS EN 60335-1:2002+A1:2004 which will be withdrawn on 2009-07-01.

BS EN 60335-1:2002 superseded BS EN 60335-1:1995 and its amendments. However, BS EN 60335-1:1995 remains valid until all the Parts 2 that are used in conjunction with it have been withdrawn. No date of withdrawal of conflicting national standards (dow) has therefore been fixed. However, when Part 1 is used for appliances not covered by a Part 2, BS EN 60335-1:1995 is not to be used after 2008-07-01.

The start and finish of text introduced or altered by amendment is indicated in the text by tags. Tags indicating changes to IEC text carry the number of the IEC amendment. For example, text altered by IEC amendment 1 is indicated by **A1)** **A1)**.

The CENELEC common modifications have been implemented at the appropriate places in the text. The start and finish of each common modification is indicated in the text by tags **C)** **C)**. Where a common modification has been introduced by amendment, the tags carry the number of the amendment. For example, the common modifications introduced by CENELEC amendment A11 are indicated by **C11)** **C11)**.

IEC Interpretation Sheet February 2007 is reproduced in National Annex NB (informative).

Amendment A12:2006 incorporates changes to subclause **29.3**.

The UK participation in its preparation was entrusted to Technical Committee CPL/61, Safety of household and similar electrical appliances.

A list of organizations represented on this committee can be obtained on request to its secretary.

This part of BS EN 60335 is to be used in conjunction with the appropriate Part 2. The Parts 2 contain clauses to supplement or modify the corresponding clauses in Part 1 to provide the relevant requirements for each type of appliance.

NOTE 1 Subclauses, notes and annexes that are additional to those in IEC 60335-1 are prefixed with the letter Z.

### Amendments/corrigenda issued since publication

Amd. No.	Date	Comments
15051	22 April 2004	Changes to subclause <b>24.5</b> , Annex G and Bibliography (cancelled and replaced by amd15172)
15172 Corrigendum No. 1	10 May 2004	Correction of page numbering
15536	8 February 2005	See national foreword
15626 Corrigendum No. 2	8 March 2005	Correction to Contents pages
16414	30 June 2006	See national foreword
16671	31 January 2007	See national foreword
16973 Corrigendum No. 3	31 August 2007	Correction to <b>25.8</b> in Annex ZA
	30 June 2008	Addition of National Annex NB, containing IEC Interpretation Sheet February 2007

This British Standard was published under the authority of the Standards Policy and Strategy Committee on 30 October 2002

© BSI 2008

NOTE 2 New editions of all Part 2 documents are in preparation for use with this new edition of BS EN 60335-1.

NOTE 3 This standard includes IEC corrigendum December 2005, which incorporates changes to subclause 30.2.3.2, H.7 and H.11.12.

The previous edition of this standard bore the title *Safety of household and similar electrical appliances — Part 1: General requirements*. For this edition, the title has been changed to that of the European Standard, which in turn based on that of the IEC standard.

This publication does not purport to include all the necessary provisions of a contract. Users are responsible for its correct application.

**Compliance with a British Standard cannot confer immunity from legal obligations.**

<http://www.china-gauges.com/>

<http://www.china-gauges.com/>

English version

Household and similar electrical appliances — Safety  
Part 1: General requirements

(IEC 60335-1:2001, modified)

Appareils électrodomestiques et analogues —  
Sécurité  
Partie 1: Prescriptions générales  
(CEI 60335-1:2001 modifiée)

Sicherheit elektrischer Geräte für den  
Hausgebrauch und ähnliche Zwecke  
Teil 1: Allgemeine Anforderungen  
(IEC 60335-1:2001, modifiziert)

This European Standard was approved by CENELEC on 2002-07-02. CENELEC members are bound to comply with the CEN/CENELEC Internal Regulations which stipulate the conditions for giving this European Standard the status of a national standard without any alteration.

Up-to-date lists and bibliographical references concerning such national standards may be obtained on application to the Central Secretariat or to any CENELEC member.

This European Standard exists in three official versions (English, French, German). A version in any other language made by translation under the responsibility of a CENELEC member into its own language and notified to the Central Secretariat has the same status as the official versions.

CENELEC members are the national electrotechnical committees of Austria, Belgium, Cyprus, Czech Republic, Denmark, Estonia, Finland, France, Germany, Greece, Hungary, Iceland, Ireland, Italy, Latvia, Lithuania, Luxembourg, Malta, Netherlands, Norway, Poland, Portugal, Romania, Slovakia, Slovenia, Spain, Sweden, Switzerland and United Kingdom.

## CENELEC

European Committee for Electrotechnical Standardization  
Comité Européen de Normalisation Electrotechnique  
Europäisches Komitee für Elektrotechnische Normung

Central Secretariat: rue de Stassart 35, B-1050 Brussels

## Foreword

The text of document 61/1965/FDIS, future fourth edition of IEC 60335-1, prepared by the IEC Technical Committee 61, was submitted to the IEC-CENELEC parallel vote in January 2001. The comments were discussed during the Delft meeting of CENELEC TC 61 in May 2001 when it was decided to submit some common modifications to the formal vote (2MV).

This draft was circulated in November 2001, but did not receive sufficient support. The comments were discussed during the Kista meeting of CENELEC TC 61 in May 2002 when it was decided to retain only the common modifications from the previous draft. This new draft was approved by CENELEC as EN 60335-1 on 2002-07-02.

The following date is applicable:

- latest date by which the EN was to be implemented at (dop) 2003-07-01  
national level by publication of an identical national standard  
or by endorsement

This European Standard replaces EN 60335-1:1994 and its amendments. However, EN 60335-1:1994 remains valid until all the parts 2 that are used in conjunction with it have been withdrawn. No date of withdrawal of conflicting national standards (dow) has therefore been fixed. However, when Part 1 is used for appliances not covered by a part 2, EN 60335-1:1994 is not to be used after 2008-07-01.

This part of EN 60335 is to be used in conjunction with the appropriate part 2. The parts 2 contain clauses to supplement or modify the corresponding clauses in Part 1 to provide the relevant requirements for each type of appliance.

NOTE 1 Subclauses, notes and annexes that are additional to those in IEC 60335-1 are prefixed with the letter Z.

Special national conditions causing a deviation from this European Standard are listed in Annex ZA. National deviations from this European Standard are listed in Annex ZB. Annexes B, C, D, E, F, G, H, I, J, K, M, N, ZA and ZC are normative and form an integral part of this standard.

Annexes A, L, O, ZB and ZD are for information only.

NOTE 2 The following annexes contain provisions suitably modified from other IEC standards:

- Annex E Needle flame test IEC 60695-2-2
- Annex F Capacitors IEC 60384-14
- Annex G Safety isolating transformers IEC 61558-1 and IEC 61558-2-6
- Annex H Switches IEC 61058-1
- Annex J Coated printed circuit boards IEC 60664-3
- Annex N Proof tracking test IEC 60112

NOTE 3 The following print types are used:

- requirements: in roman type;
- *test specifications: in italic type;*
- notes: in small roman type.

Words in **bold** in the text are defined in Clause 3. When a definition concerns an adjective, the adjective and the associated noun are also in bold.

The text of the International Standard IEC 60335-1:2001, excluding the corrigendum January 2002, was approved by CENELEC as a European Standard with agreed common modifications.

—————

### Foreword to amendment A11

EN 60335-1:2002 was approved and published without corrigendum 1 to IEC 60335-1:2001. A proposal to realign the European Standard with the International Standard was discussed during the Brussels meeting of CENELEC TC 61 in November 2002. It was decided to submit the text of the corrigendum to the formal vote for acceptance as an amendment to EN 60335-1. The draft was circulated in April 2003 and was approved by CENELEC as amendment A11 to EN 60335-1 on 2003-09-23.

The following dates are applicable:

- latest date by which the amendment has to be implemented (dop) 2004-10-01  
at national level by publication of an identical national standard or by endorsement
- date on which the national standards conflicting with the amendment have to be withdrawn (dow) 2006-10-01

### Foreword to amendment A1

The text of document 61/2569/FDIS, future amendment 1 to IEC 60335-1:2001, prepared by the IEC Technical Committee 61, was submitted to the IEC-CENELEC parallel vote and was approved by CENELEC as amendment A1 to EN 60335-1:2002 on 2004-09-22.

The following dates are applicable:

- latest date by which the amendment has to be implemented at national level by publication of an identical national standard or by endorsement (dop) 2005-07-01
- date on which national standards conflicting with the amendment have to be withdrawn (dow) 2007-10-01

This amendment supplements or modifies the corresponding clauses of EN 60335-1:2002.

Annex R is normative and forms an integral part of this standard.

Annexes P and Q are for information only.

There are no special national conditions causing a deviation from this amendment.

National deviations from this amendment are listed in Annex ZB and are in addition to those in EN 60335-1.

### Endorsement notice

The text of amendment 1:2004 to the International Standard IEC 60335-1:2001 was approved by CENELEC as an amendment to the European Standard without any modification.

### Foreword to amendment A12

This amendment to EN 60335-1:2002 was prepared by the Technical Committee CENELEC TC 61 based on a decision at the Balsthal meeting in June 2004.

The text of the draft was submitted to the Unique Acceptance Procedure in May 2005 and was approved by CENELEC as amendment A12 to EN 60335-1:2002 on 2005-12-01.

The following dates were fixed:

- latest date by which the amendment has to be implemented at national level by publication of an identical national standard or by endorsement (dop) 2006-12-01
- date on which national standards conflicting with the amendment have to be withdrawn (dow) 2007-10-01

### **Foreword to amendment A2**

The text of document 61/2996/FDIS, future amendment 2 to IEC 60335-1:2001, prepared by the IEC Technical Committee 61, Safety of household and similar electrical appliances, was submitted to the IEC-CENELEC parallel vote and was approved by CENELEC as amendment A2 to EN 60335-1:2002 on 2006-07-01.

The following dates are applicable:

- latest date by which the amendment has to be implemented at national level by publication of an identical national standard or by endorsement (dop) 2007-04-01
- date on which national standards conflicting with the amendment have to be withdrawn (dow) 2009-07-01

This amendment supplements or modifies the corresponding clauses of EN 60335-1:2002.

There are no special national conditions causing a deviation from this amendment.

There are no national deviations from this amendment.

---

### **Endorsement notice**

The text of amendment 2:2006 to the International Standard IEC 60335-1:2001 and its corrigendum August 2006 was approved by CENELEC as an amendment to the European Standard without any modification.

---



CONTENTS

INTRODUCTION.....	8
1 Scope .....	9
2 Normative references .....	9
3 Definitions .....	13
4 General requirement.....	21
5 General conditions for the tests .....	21
6 Classification.....	24
7 Marking and instructions.....	24
8 Protection against access to live parts .....	31
9 Starting of motor-operated appliances.....	33
10 Power input and current.....	33
11 Heating .....	34
12 Void .....	39
13 Leakage current and electric strength at operating temperature .....	39
14 Transient overvoltages .....	42
15 Moisture resistance .....	43
16 Leakage current and electric strength .....	45
17 Overload protection of transformers and associated circuits .....	47
18 Endurance.....	47
19 Abnormal operation .....	47
20 Stability and mechanical hazards .....	56
21 Mechanical strength .....	57
22 Construction.....	58
23 Internal wiring.....	69
24 Components .....	71
25 Supply connection and external flexible cords .....	74
26 Terminals for external conductors .....	82
27 Provision for earthing.....	85
28 Screws and connections .....	87
29 Clearances, creepage distances and solid insulation .....	90
30 Resistance to heat and fire .....	97
31 Resistance to rusting .....	101
32 Radiation, toxicity and similar hazards .....	101

Annex A (informative) Routine tests .....	112
Annex B (normative) Appliances powered by rechargeable batteries .....	114
Annex C (normative) Ageing test on motors .....	117
Annex D (normative) Thermal motor protectors .....	119
Annex E (normative) Needle flame test .....	120
Annex F (normative) Capacitors .....	121
Annex G (normative) Safety isolating transformers .....	123
Annex H (normative) Switches .....	124
Annex I (normative) Motors having basic insulation that is inadequate for the rated voltage of the appliance .....	126
Annex J (normative) Coated printed circuit boards .....	128
Annex K (normative) Overvoltage categories .....	129
Annex L (informative) Guidance for the measurement of clearances and creepage distances .....	130
Annex M (normative) Pollution degree .....	132
Annex N (normative) Proof tracking test .....	133
Annex O (informative) Selection and sequence of the tests of clause 30 .....	134
Annex P (informative) Guidance for the application of this standard to appliances used in warm damp equable climates .....	136
Annex Q (informative) Sequence of tests for the evaluation of electronic circuits .....	138
Annex R (normative) Software evaluation .....	140
Annex ZA (normative) Special national conditions .....	141
Annex ZB (informative) A-deviations .....	144
Annex ZC (normative) Normative references to international publications with their corresponding European publications .....	145
Annex ZD (informative) IEC and CENELEC code designations for flexible cords .....	150
National Annex NB (informative) IEC Interpretation Sheet February 2007 .....	156
Bibliography .....	151
Index of defined words .....	153
Figure 1 – Circuit diagram for leakage current measurement at operating temperature for single-phase connection of class II appliances .....	102
Figure 2 – Circuit diagram for leakage current measurement at operating temperature for single-phase connection of appliances, other than those of class II .....	103
Figure 3 – Circuit diagram for leakage current measurement at operating temperature for three-phase connection of class II appliances .....	104
Figure 4 – Circuit diagram for leakage current measurement at operating temperature for three-phase connection of appliances other than those of class II .....	105
Figure 5 – Void .....	105
Figure 6 – Example of an electronic circuit with low-power points .....	106
Figure 7 – Test finger nail .....	107
Figure 8 – Flexing test apparatus .....	108
Figure 9 – Constructions of cord anchorages .....	109

Figure 10 – An example of parts of an earthing terminal .....	110
Figure 11 – Examples of clearances .....	111
Figure I.1 – Simulation of faults .....	127
Figure L.1 – Sequence for the determination of clearances .....	130
Figure L.2 – Sequence for the determination of creepage distances .....	131
Figure O.1 – Tests for resistance to heat .....	134
Figure O.2 – Tests for resistance to fire .....	135
Table 1 – Power input deviation .....	33
Table 2 – Current deviation .....	34
Table 3 – Maximum normal temperature rises .....	37
Table 4 – Voltage for electric strength test .....	41
Table 5 – Characteristics of high-voltage sources .....	42
Table 6 – Impulse test voltage .....	42
Table 7 – Test voltages .....	46
Table 8 – Maximum winding temperature .....	50
Table 9 – Maximum abnormal temperature rise .....	55
Table 10 – Dimensions of cables and conduits .....	75
Table 11 – Minimum cross-sectional area of conductors .....	77
Table 12 – Pull force and torque .....	79
Table 13 – Nominal cross-sectional area of conductors .....	84
Table 14 – Torque for testing screws and nuts .....	89
Table 15 – Rated impulse voltage .....	91
Table 16 – Minimum clearances .....	91
Table 17 – Minimum creepage distances for basic insulation .....	95
Table 18 – Minimum creepage distances for functional insulation .....	96
Table A.1 – Test voltages .....	113
Table C.1 – Test conditions .....	117

## INTRODUCTION

It has been assumed in the drafting of this international standard that the execution of its provisions is entrusted to appropriately qualified and experienced persons.

This standard recognizes the internationally accepted level of protection against hazards such as electrical, mechanical, thermal, fire and radiation of appliances when operated as in normal use taking into account the manufacturer's instructions. It also covers abnormal situations that can be expected in practice and takes into account the way in which electromagnetic phenomena can affect the safe operation of appliances.

This standard takes into account the requirements of IEC 60364 as far as possible so that there is compatibility with the wiring rules when the appliance is connected to the supply mains. However, national wiring rules may differ.

If the functions of an appliance are covered by different parts 2 of IEC 60335, the relevant part 2 is applied to each function separately, as far as is reasonable. If applicable, the influence of one function on the other is taken into account.

NOTE 1 Throughout this publication, when "Part 2" is mentioned, it refers to the relevant part of IEC 60335.

This standard is a product family standard dealing with the safety of appliances and takes precedence over horizontal and generic standards covering the same subject.

Individual countries may wish to consider the application of the standard, as far as is reasonable, to appliances not mentioned in a part 2, and to appliances designed on new principles.

An appliance that complies with the text of this standard will not necessarily be considered to comply with the safety principles of the standard if, when examined and tested, it is found to have other features which impair the level of safety covered by these requirements.

An appliance employing materials or having forms of construction differing from those detailed in the requirements of this standard may be examined and tested according to the intent of the requirements and, if found to be substantially equivalent, may be considered to comply with the standard.

NOTE 2 Standards dealing with non-safety aspects of household appliances are

- IEC standards published by TC 59 concerning methods of measuring performance;
- CISPR 11, CISPR 14-1, IEC 61000-3-2 and IEC 61000-3-3 concerning electromagnetic emissions;
- CISPR 14-2 concerning electromagnetic immunity.

Ⓒ The principal objectives of the Low Voltage Directive, 73/23/EEC, are covered by this standard. The essential safety requirements of the following directives, which can be applicable to some household and similar appliances, have also been taken into account:

- 98/37/EC – Machinery directive;
- 89/106/EEC – Construction products directive;
- 97/23/EC – Pressure equipment directive. Ⓒ

# HOUSEHOLD AND SIMILAR ELECTRICAL APPLIANCES – SAFETY –

## Part 1: General requirements

### 1 Scope

This International Standard deals with the safety of electrical appliances for household and similar purposes, their ~~rated voltage~~ being not more than 250 V for single-phase appliances and 480 V for other appliances.

Appliances not intended for normal household use but which nevertheless may be a source of danger to the public, such as appliances intended to be used by laymen in shops, in light industry and on farms, are within the scope of this standard.

NOTE 1 Examples of such appliances are catering equipment, cleaning appliances for industrial and commercial use, and appliances for hairdressers.

As far as is practicable, this standard deals with the common hazards presented by appliances that are encountered by all persons in and around the home. However, in general, it does not take into account

- $\text{A}_2$  persons (including children) whose
  - physical, sensory or mental capabilities; or
  - lack of experience and knowledgeprevents them from using the appliance safely without supervision or instruction;
- children playing with the appliance.  $\text{A}_2$

NOTE 2 Attention is drawn to the fact that

- for appliances intended to be used in vehicles or on board ships or aircraft, additional requirements may be necessary;

$\text{A}_1$  *Text deleted*  $\text{A}_1$

- in many countries additional requirements are specified by the national health authorities, the national authorities responsible for the protection of labour, the national water supply authorities and similar authorities.

NOTE 3 This standard does not apply to

- appliances intended exclusively for industrial purposes;
- appliances intended to be used in locations where special conditions prevail, such as the presence of a corrosive or explosive atmosphere (dust, vapour or gas);
- audio, video and similar electronic apparatus (IEC 60065);
- appliances for medical purposes (IEC 60601);
- hand-held motor-operated electric tools (IEC 60745);
- personal computers and similar equipment (IEC 60950);
- transportable motor-operated electric tools (IEC 61029).

### 2 Normative references

The following referenced documents are indispensable for the application of this document. For dated references, only the edition cited applies. For undated references, the latest edition of the referenced document (including any amendments) applies.

$\text{A}_1$  *Text deleted*  $\text{A}_1$

IEC 60061-1, *Lamp caps and holders together with gauges for the control of interchangeability and safety – Part 1: Lamp caps*

**A1** Text deleted **A1**

**A1** IEC 60068-2-2, *Environmental testing – Part 2 Tests. Tests B: Dry heat* **A1**

IEC 60068-2-32, *Environmental testing – Part 2: Tests – Test Ed: Free fall (Procedure 1)*

IEC 60068-2-75, *Environmental testing – Part 2-75: Tests – Test Eh: Hammer tests*

IEC 60083, *Plugs and socket-outlets for domestic and similar general use standardized in member countries of IEC*

**A2** IEC 60085, *Electrical insulation – Thermal classification* **A2**

**A1** IEC 60112:2003, *Method for the determination of the proof and the comparative tracking indices of solid insulating materials* **A1**

IEC 60127 (all parts), *Miniature fuses*

IEC 60227 (all parts), *Polyvinyl chloride insulated cables of rated voltages up to and including 450/750 V*

IEC 60238, *Edison screw lampholders*

IEC 60245 (all parts), *Rubber insulated cables – Rated voltages up to and including 450/750 V*

**A2** Text deleted **A2**

**A2** IEC 60252-1, *AC motor capacitors – Part 1: General – Performance testing and rating – Safety requirements – Guide for installation and operation* **A2**

**A1** IEC 60320-1, **A1** *Appliance couplers for household and similar general purposes – Part 1: General requirements*

**A1** IEC 60320-2-2, *Appliance couplers for household and similar general purposes – Part 2-2: Interconnection couplers for household and similar equipment* **A1**

IEC 60320-2-3, *Appliance couplers for household and similar general purposes – Part 2-3: Appliance coupler with a degree of protection higher than IPX0*

**A2** IEC 60384-14:2005 **A2**, *Fixed capacitors for use in electronic equipment – Part 14: Sectional specification: Fixed capacitors for electromagnetic interference suppression and connection to the supply mains*

Ⓐ<sub>1</sub> IEC 60417-DB:2002<sup>1</sup>, *Graphical symbols for use on equipment* Ⓐ<sub>1</sub>

IEC 60529, *Degrees of protection provided by enclosures (IP Code)*

Ⓐ<sub>1</sub> IEC 60598-1:2003, Ⓐ<sub>1</sub> *Luminaires – Part 1: General requirements and tests*

Ⓐ<sub>1</sub> IEC 60664-1:1992, *Insulation coordination for equipment within low-voltage systems – Part 1: Principles, requirements and tests*

Amendment 1 (2000)

Amendment 2 (2002)<sup>2</sup> Ⓐ<sub>1</sub>

Ⓐ<sub>2</sub> IEC 60664-3:2003, *Insulation coordination for equipment within low-voltage systems – Part 3: Use of coating, potting or moulding for protection against pollution* Ⓐ<sub>2</sub>

IEC 60695-2-11, *Fire Hazard testing – Part 2-11: Glowing/hot wire based test methods – Glow-wire flammability test method for end-products*

IEC 60695-2-12, *Fire Hazard testing – Part 2-12: Glowing/hot wire based test methods – Glow-wire flammability test method for materials*

IEC 60695-2-13, *Fire Hazard testing – Part 2-13: Glowing/hot wire based test methods – Glow-wire ignitability test method for materials*

IEC 60695-10-2, *Fire hazard testing – Part 10: Guidance and test methods for the minimization of the effects of abnormal heat on electrotechnical products involved in fires – Section 2: Method for testing products made from non-metallic materials for resistance to heat using the ball pressure test*

Ⓐ<sub>2</sub> IEC 60695-11-5:2004, *Fire hazard testing – Part 11-5: Test flames – Needle-flame test method – Apparatus, confirmatory test arrangement and guidance* Ⓐ<sub>2</sub>

Ⓐ<sub>1</sub> IEC 60695-11-10, Ⓐ<sub>1</sub> *Fire hazard testing – Part 11-10: Test flames – 50 W horizontal and vertical flame test methods*

Ⓐ<sub>2</sub> IEC 60730-1:1999, *Automatic electrical controls for household and similar use – Part 1: General requirements*

Amendment 1 (2003)<sup>3</sup> Ⓐ<sub>2</sub>

Ⓐ<sub>2</sub> IEC 60730-2-8:2000, *Automatic electrical controls for household and similar use – Part 2-8: Particular requirements for electrically operated water valves, including mechanical requirements*

Amendment 1 (2002)<sup>4</sup> Ⓐ<sub>2</sub>

IEC 60738-1, *Thermistors – Directly heated positive step-function temperature coefficient – Part 1: Generic specification*

IEC 60906-1, *IEC system of plugs and socket-outlets for household and similar purposes – Part 1: Plugs and socket-outlets 16 A 250 V a.c.*

IEC 60990:1999, *Methods of measurement of touch-current and protective conductor current*

Ⓐ<sub>1</sub> *Text deleted* Ⓐ<sub>1</sub>

<sup>1</sup> DB refers to the IEC online database.

<sup>2</sup> There exists a consolidated edition 1.2 (2002) that includes edition 1 and its amendments 1 and 2.

<sup>3</sup> There exists a consolidated edition 3.1 (2003) that includes edition 3 and its amendment 1.

<sup>4</sup> There exists a consolidated edition 2.1 (2003) that includes edition 2 and its amendment 1.

Ⓐ<sub>1</sub> IEC 60999-1:1999, *Connecting devices – Electrical copper conductors – Safety requirements for screw-type and screwless-type clamping units – Part 1: General requirements and particular requirements for clamping units for conductors from 0,2 mm<sup>2</sup> up to 35 mm<sup>2</sup> (included)* Ⓐ<sub>1</sub>

Ⓐ<sub>1</sub> IEC 61000-4-2, *Electromagnetic compatibility (EMC) – Part 4: Testing and measurement techniques – Section 2: Electrostatic discharge immunity test* Ⓐ<sub>1</sub>

Ⓐ<sub>1</sub> IEC 61000-4-3, *Electromagnetic compatibility (EMC) – Part 4-3: Testing and measurement techniques – Radiated, radio-frequency, electromagnetic field immunity test*

IEC 61000-4-4, *Electromagnetic compatibility (EMC) – Part 4: Testing and measurement techniques – Section 4: Electrical fast transient/burst immunity test*

IEC 61000-4-5, *Electromagnetic compatibility (EMC) – Part 4: Testing and measurement techniques – Section 5: Surge immunity test*

IEC 61000-4-6, *Electromagnetic compatibility (EMC) – Part 4-6: Testing and measurement techniques – Immunity to conducted disturbances, induced by radio-frequency fields* Ⓐ<sub>1</sub>

Ⓐ<sub>2</sub> IEC 61000-4-11:2004, *Electromagnetic compatibility (EMC) – Part 4-11: Testing and measurement techniques – Voltage dips, short interruptions and voltage variations immunity tests* Ⓐ<sub>2</sub>

Ⓐ<sub>1</sub> IEC 61000-4-13, *Electromagnetic compatibility (EMC) – Part 4-13: Testing and measurement techniques – Harmonics and interharmonics including mains signalling at a.c. power port, low frequency immunity tests* Ⓐ<sub>1</sub>

IEC 61032:1997, *Protection of persons and equipment by enclosures – Probes for verification*

Ⓐ<sub>1</sub> IEC 61058-1:2000, *Switches for appliances – Part 1: General requirements*  
Amendment 1 (2001)<sup>5</sup> Ⓐ<sub>1</sub>

Ⓐ<sub>1</sub> *Text deleted* Ⓐ<sub>1</sub>

IEC 61180-1, *High-voltage test techniques for low-voltage equipment. Part 1: Definitions, test and procedure requirements*

IEC 61180-2, *High-voltage techniques for low-voltage equipment – Part 2: Test equipment*

Ⓐ<sub>2</sub> IEC 61558-1:1997, *Safety of power transformers, power supply units and similar – Part 1: General requirements and tests*  
Amendment 1(1998)<sup>6</sup> Ⓐ<sub>2</sub>

IEC 61558-2-6:1997, *Safety of power transformers, power supply units and similar – Part 2: Particular requirements for safety isolating transformers for general use*

Ⓐ<sub>1</sub> IEC 61770, *Electric appliances connected to the water mains – Avoidance of backsiphonage and failure of hose-sets* Ⓐ<sub>1</sub>

ISO 2768-1, *General tolerances – Part 1: Tolerances for linear and angular dimensions without individual tolerance indications*

Ⓐ<sub>2</sub> ISO 7000-DB:2004 Ⓐ<sub>2</sub>, *Graphical symbols for use on equipment – Index and synopsis*

Ⓐ<sub>2</sub> ISO 9772:2001, *Cellular plastics – Determination of horizontal burning characteristics of small specimens subjected to a small flame*  
Amendment 1 (2003) Ⓐ<sub>2</sub>

Ⓐ<sub>2</sub> IEC 60691:2002, *Thermal-links – Requirements and application guide* Ⓐ<sub>2</sub>

Ⓐ<sub>2</sub> IEC 62151, *Safety of equipment electrically connected to a telecommunication network* Ⓐ<sub>2</sub>

<sup>5</sup> There exists a consolidated edition 3.1 (2001) that includes edition 3 and its amendment 1.

<sup>6</sup> There exists a consolidated edition 1.1 (1998) that includes edition 1 and its amendment 1.



### 3 Definitions

Ⓐ) An Index of the defined terms is provided at the end of this publication. Ⓐ)

#### 3.1

When the terms “voltage” and “current” are used, they are r.m.s. values, unless otherwise specified.

##### 3.1.1

###### **rated voltage**

voltage assigned to the appliance by the manufacturer

##### 3.1.2

###### **rated voltage range**

voltage range assigned to the appliance by the manufacturer, expressed by its lower and upper limits

##### 3.1.3

###### **working voltage**

maximum voltage to which the part under consideration is subjected when the appliance is supplied at its **rated voltage** and operating under **normal operation**

NOTE 1 The different positions of controls and switching devices are taken into account.

NOTE 2 **Working voltage** takes into account resonant voltages.

NOTE 3 When deducing the **working voltage**, the effect of transient voltages is ignored.

##### 3.1.4

###### **rated power input**

power input assigned to the appliance by the manufacturer

##### 3.1.5

###### **rated power input range**

power input range assigned to the appliance by the manufacturer, expressed by its lower and upper limits

##### 3.1.6

###### **rated current**

current assigned to the appliance by the manufacturer

NOTE If no current is assigned to the appliance, the **rated current** is

- for **heating appliances**, the current calculated from the **rated power input** and the **rated voltage**;
- for **motor-operated appliances** and **combined appliances**, the current measured when the appliance is supplied at **rated voltage** and operated under **normal operation**.

##### 3.1.7

###### **rated frequency**

frequency assigned to the appliance by the manufacturer

##### 3.1.8

###### **rated frequency range**

frequency range assigned to the appliance by the manufacturer, expressed by its lower and upper limits

### 3.1.9

#### **normal operation**

conditions under which the appliance is operated in normal use when it is connected to the supply mains

### 3.1.10

#### **rated impulse voltage**

voltage derived from the **rated voltage** and the overvoltage category of the appliance, characterizing the specified withstand capability of its insulation against transient over-voltages

### A1 3.1.11

#### **dangerous malfunction**

unintended operation of the appliance that may impair safety A1

### A2 3.1.12

#### **remote operation**

control of an appliance by a command that can be initiated out of sight of the appliance using means such as telecommunications, sound controls or bus systems

NOTE An infra-red control by itself is not considered one used for **remote operation**. However, it may be incorporated as part of a system such as a telecommunication, sound control or bus system. A2

## 3.2

### 3.2.1

#### **detachable cord**

flexible cord, for supply or interconnection, intended to be connected to the appliance by means of a suitable appliance coupler

### 3.2.2

#### **interconnection cord**

external flexible cord provided as part of a complete appliance for purposes other than connection to the supply mains

NOTE A remote hand-held switching device, an external interconnection between two parts of an appliance and a cord connecting an accessory to the appliance or to a separate signalling circuit are examples of **interconnection cords**.

### 3.2.3

#### **supply cord**

flexible cord, for supply purposes, that is fixed to the appliance

### 3.2.4

#### **type X attachment**

method of attachment of the **supply cord** such that it can easily be replaced

NOTE The **supply cord** may be specially prepared and only available from the manufacturer or its service agent. A specially prepared cord may include a part of the appliance.

### 3.2.5

#### **type Y attachment**

method of attachment of the **supply cord** such that any replacement is intended to be made by the manufacturer, its service agent or similar qualified person

### 3.2.6

#### **type Z attachment**

method of attachment of the **supply cord** such that it cannot be replaced without breaking or destroying the appliance

### 3.2.7

#### **supply leads**

set of wires intended for connecting the appliance to fixed wiring and accommodated in a compartment within or attached to the appliance

### 3.3

#### 3.3.1

##### **basic insulation**

insulation applied to **live parts** to provide basic protection against electric shock

#### 3.3.2

##### **supplementary insulation**

independent insulation applied in addition to **basic insulation**, in order to provide protection against electric shock in the event of a failure of **basic insulation**

#### 3.3.3

##### **double insulation**

insulation system comprising both **basic insulation** and **supplementary insulation**

#### 3.3.4

##### **reinforced insulation**

single insulation applied to **live parts**, that provides a degree of protection against electric shock equivalent to **double insulation** under the conditions specified in this standard

NOTE It is not implied that the insulation is one homogeneous piece. The insulation may comprise several layers which cannot be tested singly as **supplementary insulation** or **basic insulation**.

#### 3.3.5

##### **functional insulation**

insulation between conductive parts of different potential which is necessary only for the proper functioning of the appliance

#### 3.3.6

##### **protective impedance**

impedance connected between **live parts** and **accessible conductive parts** of **class II constructions** so that the current, in normal use and under likely fault conditions in the appliance, is limited to a safe value

#### 3.3.7

##### **class 0 appliance**

appliance in which protection against electric shock relies upon **basic insulation** only, there being no means for the connection of conductive **accessible parts**, if any, to the protective conductor in the fixed wiring of the installation, reliance in the event of a failure of the **basic insulation** being placed upon the environment

NOTE **Class 0 appliances** have either an enclosure of insulating material which may form a part or the whole of the **basic insulation**, or a metal enclosure which is separated from **live parts** by an appropriate insulation. If an appliance with an enclosure of insulating material has provision for earthing internal parts, it is considered to be a **class I appliance** or **class 0I appliance**.

#### 3.3.8

##### **class 0I appliance**

appliance having at least **basic insulation** throughout and incorporating an earthing terminal but having a **supply cord** without earthing conductor and a plug without earthing contact

### 3.3.9

#### **class I appliance**

appliance in which protection against electric shock does not rely on **basic insulation** only but which includes an additional safety precaution, in that conductive **accessible parts** are connected to the protective earthing conductor in the fixed wiring of the installation in such a way that conductive **accessible parts** cannot become live in the event of a failure of the **basic insulation**

NOTE This provision includes a protective earthing conductor in the supply cord.

### 3.3.10

#### **class II appliance**

appliance in which protection against electric shock does not rely on **basic insulation** only but in which additional safety precautions are provided, such as **double insulation** or **reinforced insulation**, there being no provision for protective earthing or reliance upon installation conditions

NOTE 1 Such an appliance may be of one of the following types:

- an appliance having a durable and substantially continuous enclosure of insulating material which envelops all metal parts, with the exception of small parts, such as nameplates, screws and rivets, which are isolated from **live parts** by insulation at least equivalent to **reinforced insulation**; such an appliance is called an insulation-encased **class II appliance**;
- an appliance having a substantially continuous metal enclosure, in which **double insulation** or **reinforced insulation** is used throughout; such an appliance is called a metal-encased **class II appliance**;
- an appliance which is a combination of an insulation-encased **class II appliance** and a metal-encased **class II appliance**.

NOTE 2 The enclosure of an insulation-encased **class II appliance** may form a part or the whole of the **supplementary insulation** or of the **reinforced insulation**.

NOTE 3 If an appliance with **double insulation** or **reinforced insulation** throughout has provision for earthing, it is considered to be a **class I appliance** or a **class 0I appliance**.

### 3.3.11

#### **class II construction**

part of an appliance for which protection against electric shock relies upon **double insulation** or **reinforced insulation**

### 3.3.12

#### **class III appliance**

appliance in which protection against electric shock relies on supply at **safety extra-low voltage** and in which voltages higher than those of **safety extra-low voltage** are not generated

### 3.3.13

#### **class III construction**

part of an appliance for which protection against electric shock relies upon **safety extra-low voltage** and in which voltages higher than those of **safety extra-low voltage** are not generated

### 3.3.14

#### **clearance**

shortest distance in air between two conductive parts or between a conductive part and the **accessible surface**

### 3.3.15

#### **creepage distance**

shortest distance along the surface of insulation between two conductive parts or between a conductive part and the **accessible surface**

### 3.4

#### 3.4.1

##### **extra-low voltage**

voltage supplied from a source within the appliance that does not exceed 50 V between conductors and between conductors and earth when the appliance is supplied at **rated voltage**

#### 3.4.2

##### **safety extra-low voltage**

voltage not exceeding 42 V between conductors and between conductors and earth, the no-load voltage not exceeding 50 V

When **safety extra-low voltage** is obtained from the supply mains, it is to be through a **safety isolating transformer** or a convertor with separate windings, the insulation of which complies with **double insulation** or **reinforced insulation** requirements.

NOTE 1 The voltage limits specified are based on the assumption that the **safety isolating transformer** is supplied at its rated voltage.

NOTE 2 **Safety extra-low voltage** is also known as SELV.

#### 3.4.3

##### **safety isolating transformer**

transformer, the input winding of which is electrically separated from the output winding by an insulation at least equivalent to **double insulation** or **reinforced insulation**, that is intended to supply an appliance or circuit at **safety extra-low voltage**

#### 3.4.4

##### **protective extra-low voltage circuit**

earthed circuit operating at **safety extra-low voltage** which is separated from other circuits by **basic insulation** and protective screening, **double insulation** or **reinforced insulation**

NOTE 1 Protective screening is the separation of circuits from **live parts** by means of an earthed screen.

NOTE 2 A **protective extra-low voltage circuit** is also known as a PELV circuit.

### 3.5

#### 3.5.1

##### **portable appliance**

appliance that is intended to be moved while in operation or an appliance, other than a **fixed appliance**, having a mass less than 18 kg

#### 3.5.2

##### **hand-held appliance**

**portable appliance** intended to be held in the hand during normal use

#### 3.5.3

##### **stationary appliance**

**fixed appliance** or an appliance which is not a **portable appliance**

#### 3.5.4

##### **fixed appliance**

appliance that is intended to be used while fastened to a support or while secured in a specific location

ⓘ Note deleted ⓘ

#### 3.5.5

##### **built-in appliance**

**fixed appliance** intended to be installed in a cabinet, in a prepared recess in a wall or in a similar location

#### 3.5.6

##### **heating appliance**

appliance incorporating heating elements but without any motor

#### 3.5.7

##### **motor-operated appliance**

appliance incorporating motors but without any heating element

NOTE Magnetically driven appliances are considered to be **motor-operated appliances**.

#### 3.5.8

##### **combined appliance**

appliance incorporating heating elements and motors

### 3.6

#### 3.6.1

##### **non-detachable part**

part that can only be removed or opened with the aid of a **tool** or a part that fulfills the test of 22.11

#### 3.6.2

##### **detachable part**

part that can be removed without the aid of a **tool**, a part that is removed in accordance with the instructions for use, even if a **tool** is needed for removal, or a part that does not fulfil the test of 22.11

NOTE 1 If for installation purposes a part has to be removed, this part is not considered to be detachable even if the instructions state that it is to be removed.

NOTE 2 Components that can be removed without the aid of a **tool** are considered to be **detachable parts**.

NOTE 3 A part that can be opened is considered to be a part that can be removed.

#### 3.6.3

##### **accessible part**

part or surface that can be touched by means of test probe B of IEC 61032, and if the part or surface is metal, any conductive part connected to it

ⓘ NOTE **Accessible non-metallic parts** with conductive coatings are considered to be **accessible metal parts**. ⓘ

### 3.6.4

#### **live part**

conductor or conductive part intended to be energized in normal use, including a neutral conductor but, by convention, not a PEN conductor

NOTE 1 Parts, accessible or not, complying with 8.1.4 are not considered to be live parts

NOTE 2 A PEN conductor is a protective earthed neutral conductor combining the functions of both a protective conductor and a neutral conductor.

### 3.6.5

#### **tool**

screwdriver, coin or any other object that may be used to operate a screw or similar fixing means

## 3.7

### 3.7.1

#### **thermostat**

temperature-sensing device, the operating temperature of which may be either fixed or adjustable and which during **normal operation** keeps the temperature of the controlled part between certain limits by automatically opening and closing a circuit

### 3.7.2

#### **temperature limiter**

temperature-sensing device, the operating temperature of which may be either fixed or adjustable and which during **normal operation** operates by opening or closing a circuit when the temperature of the controlled part reaches a predetermined value

NOTE It does not make the reverse operation during the normal duty cycle of the appliance. It may or may not require manual resetting.

### 3.7.3

#### **thermal cut-out**

device which during abnormal operation limits the temperature of the controlled part by automatically opening the circuit, or by reducing the current, and is constructed so that its setting cannot be altered by the user

### 3.7.4

#### **self-resetting thermal cut-out**

**thermal cut-out** that automatically restores the current after the relevant part of the appliance has cooled down sufficiently

### 3.7.5

#### **non-self-resetting thermal cut-out**

**thermal cut-out** that requires a manual operation for resetting, or replacement of a part, in order to restore the current

NOTE Manual operation includes disconnection of the appliance from the supply mains.

### 3.7.6

#### **protective device**

device, the operation of which prevents a hazardous situation under abnormal operation conditions

### 3.7.7

#### **thermal link**

**thermal cut-out** which operates only once and requires partial or complete replacement

### 3.8

#### 3.8.1

##### **all-pole disconnection**

disconnection of both supply conductors by a single initiating action or, for three-phase appliances, disconnection of the three supply conductors by a single initiating action

NOTE For three-phase appliances, the neutral conductor is not considered to be a supply conductor.

#### 3.8.2

##### **off position**

stable position of a switching device in which the circuit controlled by the switch is disconnected from its supply  $\text{A}_1$  or, for electronic disconnection, the circuit is de-energized  $\text{A}_1$

NOTE The **off position** does not imply an **all-pole disconnection**.

#### 3.8.3

##### **visibly glowing heating element**

heating element that is partly or completely visible from the outside of the appliance and has a temperature of at least 650 °C when the appliance has been operated under **normal operation at rated power input** until steady conditions have been established

#### 3.8.4

##### **PTC heating element**

element intended for heating consisting mainly of positive temperature coefficient resistors that are thermally sensitive and have a rapid non-linear increase in resistance when the temperature is raised through a particular range

#### 3.8.5

##### **user maintenance**

any maintenance operation stated in the instructions for use, or marked on the appliance, that the user is intended to perform

### 3.9

#### 3.9.1

##### **electronic component**

part in which conduction is achieved principally by electrons moving through a vacuum, gas or semiconductor

NOTE Neon indicators are not considered to be **electronic components**.

#### 3.9.2

##### **electronic circuit**

circuit incorporating at least one **electronic component**

#### $\text{A}_1$ 3.9.3

##### **protective electronic circuit**

**electronic circuit** that prevents a hazardous situation under abnormal operating conditions

NOTE Parts of the circuit may also be used for functional purposes.  $\text{A}_1$



**A1** 3.9.4

**software class B**

software that includes code intended to prevent hazards if a fault, other than a software fault, occurs in the appliance

3.9.5

**software class C**

software that includes code intended to prevent hazards without the use of other **protective devices** **A1**

## 4 General requirement

Appliances shall be constructed so that in normal use they function safely so as to cause no danger to persons or surroundings, even in the event of carelessness that may occur in normal use.

*In general this principle is achieved by fulfilling the relevant requirements specified in this standard and compliance is checked by carrying out all the relevant tests.*

## 5 General conditions for the tests

Unless otherwise specified, the tests are carried out in accordance with this clause.

### 5.1 Tests according to this standard are type tests.

NOTE Routine tests are described in annex A.

**5.2** *The tests are carried out on a single appliance that shall withstand all the relevant tests. However, the tests of clauses 20, 22 (except 22.11 and 22.18) to 26, 28, 30 and 31 may be carried out on separate appliances. The test of 22.3 is carried out on a new appliance.*

NOTE 1 Additional samples may be required if the appliance has to be tested under different conditions, for example if it can be supplied with different voltages.

If an intentionally weak part becomes open circuit during the tests of clause 19, an additional appliance may be needed.

The testing of components may require the submission of additional samples of these components.

If the test of annex C has to be carried out, six samples of the motor are needed.

**A1** If the test of annex D has to be carried out, an additional appliance may be used. **A1**

If the tests of annex G are carried out, four additional transformers are needed.

If the tests of annex H are carried out, three switches or three additional appliances are needed.

NOTE 2 The cumulative stress resulting from successive tests on **electronic circuits** is to be avoided. It may be necessary to replace components or to use additional samples. The number of additional samples should be kept to a minimum by an evaluation of the relevant **electronic circuits**.

NOTE 3 If an appliance has to be dismantled in order to carry out a test, care is to be taken to insure that it is reassembled as originally supplied. In case of doubt, subsequent tests may be carried out on a separate sample.

**5.3** *The tests are carried out in the order of the clauses. However, the test of 22.11 on the appliance at room temperature is carried out before the tests of clause 8. **A1** The tests of clause 14 and 21.2 and 22.4 are carried out after the tests of clause 29. **A1** **A2** The test of 19.14 is carried out before the tests of 19.11. **A2***

*If it is evident from the construction of the appliance that a particular test is not applicable, the test is not carried out.*

**5.4** When testing appliances that are also supplied by other energies such as gas, the influence of their consumption has to be taken into account.

**5.5** The tests are carried out with the appliance or any movable part of it placed in the most unfavourable position that may occur in normal use.

**5.6** Appliances provided with controls or switching devices are tested with these controls or devices adjusted to their most unfavourable setting, if the setting can be altered by the user.

NOTE 1 If the adjusting means of the control is accessible without the aid of a **tool**, this subclause applies whether the setting can be altered by hand or with the aid of a **tool**. If the adjusting means is not accessible without the aid of a **tool** and if the setting is not intended to be altered by the user, this subclause does not apply.

NOTE 2 Adequate sealing is regarded as preventing alteration of the setting by the user.

**5.7** The tests are carried out in a draught-free location at an ambient temperature of  $20\text{ }^{\circ}\text{C} \pm 5\text{ }^{\circ}\text{C}$ .

If the temperature attained by any part is limited by a temperature sensitive device or is influenced by the temperature at which a change of state occurs, for example when water boils, the ambient temperature is maintained at  $23\text{ }^{\circ}\text{C} \pm 2\text{ }^{\circ}\text{C}$  in case of doubt.

**5.8.1** Appliances for a.c. only are tested with a.c. at **rated frequency**, and those for a.c. and d.c. are tested at the more unfavourable supply.

Appliances for a.c. that are not marked with **rated frequency** or are marked with a frequency range of 50 Hz to 60 Hz are tested with either 50 Hz or 60 Hz, whichever is the more unfavourable.

**5.8.2** Appliances having more than one **rated voltage** are tested on the basis of the most unfavourable voltage.

For **motor-operated appliances**, and **combined appliances**, marked with a **rated voltage range**, when it is specified that the supply voltage is equal to the **rated voltage** multiplied by a factor, the appliance is supplied at

- the upper limit of the **rated voltage range** multiplied by this factor, if greater than 1;
- the lower limit of the **rated voltage range** multiplied by this factor, if smaller than 1.

When a factor is not specified, the supply voltage is the most unfavourable within the **rated voltage range**.

NOTE 1 If a **heating appliance** has a **rated voltage range**, the upper limit of the voltage range will usually be the most unfavourable voltage within the range.

NOTE 2 For **motor-operated appliances**, **combined appliances** and appliances having more than one **rated voltage** or **rated voltage range**, it may be necessary to make some of the tests at the minimum, the mean and the maximum values of the **rated voltage** or the **rated voltage range** in order to establish the most unfavourable voltage.

**5.8.3** For **heating appliances**, and **combined appliances**, marked with a **rated power input range**, when it is specified that the power input is equal to the **rated power input** multiplied by a factor, the appliance is operated at

- the upper limit of the **rated power input range** multiplied by this factor, if greater than 1;
- the lower limit of the **rated power input range** multiplied by this factor, if smaller than 1.

When a factor is not specified, the power input is the most unfavourable within the **rated power input range**.

**5.8.4** For appliances marked with a **rated voltage range** and **rated power input** corresponding to the mean of the **rated voltage range**, when it is specified that the power input is equal to **rated power input** multiplied by a factor, the appliance is operated at

- the calculated power input corresponding to the upper limit of the **rated voltage range** multiplied by this factor, if greater than 1;
- the calculated power input corresponding to the lower limit of the **rated voltage range** multiplied by this factor, if smaller than 1.

When a factor is not specified, the power input corresponds to the power input at the most unfavourable voltage within the **rated voltage range**.

**5.9** When alternative heating elements or accessories are made available by the appliance manufacturer, the appliance is tested with those elements or accessories which give the most unfavourable results.

**5.10** The tests are carried out on the appliance as supplied. However, an appliance constructed as a single appliance but supplied in a number of units is tested after assembly in accordance with the instructions provided with the appliance.

**Built-in appliances** and **fixed appliances** are installed in accordance with the instructions provided with the appliance before testing.

**5.11** Appliances intended to be connected to fixed wiring by means of a flexible cord are tested with the appropriate flexible cord connected to the appliance.

**5.12** For **heating appliances** and **combined appliances**, when it is specified that the appliance has to operate at a power input multiplied by a factor, this applies only to heating elements without appreciable positive temperature coefficient of resistance.

For heating elements with appreciable positive temperature coefficient of resistance, other than **PTC heating elements**, the supply voltage is determined by supplying the appliance at **rated voltage** until the heating element reaches its operating temperature. The supply voltage is then rapidly increased to the value necessary to give the power input required for the relevant test, this value of the supply voltage being maintained throughout the test.

NOTE In general, the temperature coefficient is considered to be appreciable if, at **rated voltage**, the power input of the appliance in cold condition differs by more than 25 % from the power input at operating temperature.

**5.13** The tests for appliances with **PTC heating elements** are carried out at a voltage corresponding to the specified power input. When a power input greater than the **rated power input** is specified, the factor for multiplying the voltage is equal to the square root of the factor for multiplying the power input.

**5.14** If **class 0I appliances** or **class I appliances** have **accessible metal parts** that are not earthed and are not separated from **live parts** by an intermediate metal part that is earthed, such parts are checked for compliance with the appropriate requirements specified for **class II construction**.

If **class 0I appliances** or **class I appliances** have **accessible non-metallic parts**, such parts are checked for compliance with the appropriate requirements specified for **class II construction** unless these parts are separated from **live parts** by an intermediate metal part that is earthed.

**[A1]** NOTE Guidance is given in Annex P for enhanced requirements that may be used to ensure an acceptable level of protection against electrical and thermal hazards for particular types of appliances used in an installation without a protective earthing conductor in countries that have warm damp equable climates. **[A1]**

**5.15** If appliances have parts operating at **safety extra-low voltage**, such parts are checked for compliance with the appropriate requirements specified for **class III construction**.

**5.16** When testing **electronic circuits**, the supply is to be free from perturbations from external sources that can influence the results of the tests.

**5.17** Appliances powered by rechargeable batteries are tested in accordance with annex B.

**5.18** If linear and angular dimensions are specified without a tolerance, ISO 2768-1 is applicable.

## 6 Classification

**6.1** Appliances shall be of one of the following classes with respect to protection against electric shock:

☐ text deleted ☐ **class I, class II, class III.**

*Compliance is checked by inspection and by the relevant tests.*

**6.2** Appliances shall have the appropriate degree of protection against harmful ingress of water.

*Compliance is checked by inspection and by the relevant tests.*

NOTE The degrees of protection against harmful ingress of water are given in IEC 60529.

## 7 Marking and instructions

**7.1** Appliances shall be marked with the

- **rated voltage** or **rated voltage range** in volts;
- symbol for nature of supply, unless the **rated frequency** is marked;
- **rated power input** in watts or **rated current** in amperes;
- name, trade mark or identification mark of the manufacturer or responsible vendor;
- model or type reference;
- symbol 5172 of IEC 60417, for **class II appliances** only;
- IP number according to degree of protection against ingress of water, other than IPX0.

☐ The marking of **rated voltage** or **rated voltage range**, for appliances intended to be connected to the supply mains, shall cover:

- 230 V for single-phase appliances;
- 400 V for multi-phase appliances. ☐

*Compliance is checked by inspection.*

NOTE 1 The first numeral of the IP number need not be marked on the appliance.

NOTE 2 Additional markings are allowed provided they do not give rise to misunderstanding.

NOTE 3 If components are marked separately, the marking of the appliance and that of the components is to be such that there can be no doubt with regard to the marking of the appliance itself.

NOTE 4 If the appliance is marked with rated pressure, the units used may be bars but only together with pascals and placed in brackets.

$\square_{A1}$  The enclosure of electrically-operated water valves incorporated in external hose-sets for connection of an appliance to the water mains shall be marked with symbol IEC 60417-5036 (DB:2002-10) if their **working voltage** exceeds **extra-low voltage**.  $\square_{A1}$

**7.2 Stationary appliances** for multiple supply shall be marked with the substance of the following:

Warning: Before obtaining access to terminals, all supply circuits must be disconnected.

This warning shall be placed in the vicinity of the terminal cover.

*Compliance is checked by inspection.*

**7.3** Appliances having a range of rated values and which can be operated without adjustment throughout the range shall be marked with the lower and upper limits of the range separated by a hyphen.

NOTE 1 Example: 115-230 V: The appliance is suitable for any value within the marked range (a curling iron with a PTC heating element).

Appliances having different rated values and which have to be adjusted for use at a particular value by the user or installer shall be marked with the different values separated by an oblique stroke.

NOTE 2 Example: 115/230 V: The appliance is only suitable for the marked values (a shaver with a selector switch).

NOTE 3 This requirement is also applicable to appliances with provision for connection to both single-phase and multi-phase supplies.

Example: 230 V/400 V: The appliance is only suitable for the voltage values indicated, 230 V being for single-phase operation and 400 V for three-phase operation (a dishwasher with terminals for both supplies).

*Compliance is checked by inspection.*

**7.4** If the appliance can be adjusted for different **rated voltages**, the voltage to which the appliance is adjusted shall be clearly discernible.

NOTE If frequent changes in voltage setting are not required, this requirement is considered to be met if the **rated voltage** to which the appliance is to be adjusted can be determined from a wiring diagram fixed to the appliance. The wiring diagram may be on the inside of a cover that has to be removed to connect the supply conductors. It is not to be on a label loosely attached to the appliance.

*Compliance is checked by inspection.*

**7.5** For appliances marked with more than one **rated voltage** or with one or more **rated voltage ranges**, the **rated power input** or **rated current** for each of these voltages or ranges shall be marked. However, if the difference between the limits of a **rated voltage range** does not exceed 10 % of the  $\square_{A2}$  arithmetic mean value  $\square_{A2}$  of the range, the marking for **rated power input** or **rated current** may be related to the  $\square_{A2}$  arithmetic mean value  $\square_{A2}$  of the range.



The upper and lower limits of the **rated power input** or **rated current** shall be marked on the appliance so that the relation between input and voltage is clear.

*Compliance is checked by inspection.*

## 7.6 When symbols are used, they shall be as follows

 [symbol 5031 of IEC 60417] direct current

 [symbol 5032 of IEC 60417] alternating current

 3  [symbol IEC 60417-5032-1 (DB:2002-10)] three-phase alternating current

3N  [symbol IEC 60417-5032-2 (DB:2002-10)] three-phase alternating current with neutral 

 [symbol 5016 of IEC 60417] fuse-link

NOTE 1 The rated current of the fuse link may be indicated in association with this symbol.



 time-lag miniature fuse-link where X is the symbol for the time/current characteristic as given in IEC 60127

 [symbol 5019 of IEC 60417] protective earth



 [symbol 5172 of IEC 60417] class II equipment



 [symbol 5012 of IEC 60417] lamp



NOTE 2 The rated wattage of the lamp may be indicated in association with this symbol.

  [symbol ISO 7000-1641 (DB:2004-01)] operator's manual; operating instructions 

 [symbol 0434 of ISO 7000] caution

  [symbol IEC 60417-5021 (DB:2002-10)] equipotentiality

 [symbol IEC 60417-5036 (DB:2002-10)] dangerous voltage 

  [symbol ISO 7000-0790 (DB:2004-01)] read operator's manual 

The symbol for nature of supply shall be placed next to the marking for **rated voltage**.

The symbol for **class II appliances** shall be placed so that it will be obvious that it is a part of the technical information and is unlikely to be confused with any other marking.

Units of physical quantities and their symbols shall be those of the international standardized system.

*Compliance is checked by inspection.*

NOTE 3 Additional symbols are allowed provided that they do not give rise to misunderstanding.

NOTE 4 Symbols specified in IEC 60417 and ISO 7000 may be used.

**7.7** Appliances to be connected to more than two supply conductors and appliances for multiple supply shall have a connection diagram fixed to them, unless the correct mode of connection is obvious.

*Compliance is checked by inspection.*

NOTE 1 The correct mode of connection for three-phase appliances is considered to be obvious if the terminals for the supply conductors are indicated by arrows pointing towards the terminals.

NOTE 2 Marking in words is an acceptable means of indicating the correct mode of connection.

NOTE 3 The connection diagram may be the wiring diagram referred to in 7.4.

**7.8** Except for **type Z attachment**, terminals used for connection to the supply mains shall be indicated as follows:

- terminals intended exclusively for the neutral conductor shall be indicated by the letter N;
- protective earthing terminals shall be indicated by symbol 5019 of IEC 60417.

These indications shall not be placed on screws, removable washers or other parts which can be removed when conductors are being connected.

*Compliance is checked by inspection.*

**7.9** Unless it is obviously unnecessary, switches which may give rise to a hazard when operated shall be marked or placed so as to indicate clearly which part of the appliance they control. Indications used for this purpose shall, wherever practicable, be comprehensible without a knowledge of languages or national standards.

*Compliance is checked by inspection.*

**7.10** The different positions of switches on **stationary appliances** and the different positions of controls on all appliances shall be indicated by figures, letters or other visual means.

NOTE 1 This requirement also applies to switches which are part of a control.

If figures are used for indicating the different positions, the **off position** shall be indicated by the figure 0 and the position for a higher value, such as output, input, speed or cooling effect, shall be indicated by a higher figure.

The figure 0 shall not be used for any other indication unless it is positioned and associated with other numbers so that it does not give rise to confusion with the indication of the **position**.

NOTE 2 For example, figure 0 may be used on a digital programming keyboard.

*Compliance is checked by inspection.*

**7.11** Controls intended to be adjusted during installation or in normal use shall be provided with an indication for the direction of adjustment.

NOTE An indication of + and – is considered to be sufficient.

*Compliance is checked by inspection.*

**7.12** Instructions for use shall be provided with the appliance so that the appliance can be used safely.

NOTE Instructions for use may be marked on the appliance as long as they are visible in normal use.

If it is necessary to take precautions during **user maintenance**, appropriate details shall be given.

**A2** The instructions shall state the substance of the following:

This appliance is not intended for use by persons (including children) with reduced physical, sensory or mental capabilities, or lack of experience and knowledge, unless they have been given supervision or instruction concerning use of the appliance by a person responsible for their safety.

Children should be supervised to ensure that they do not play with the appliance. **A2**

*Compliance is checked by inspection.*

**7.12.1** If it is necessary to take precautions during installation of the appliance, appropriate details shall be given.

*Compliance is checked by inspection.*

**7.12.2** If a **stationary appliance** is not fitted with a **supply cord** and a plug, or with other means for disconnection from the supply mains having a contact separation in all poles that provide full disconnection under overvoltage category III conditions, the instructions shall state that means for disconnection must be incorporated in the fixed wiring in accordance with the wiring rules.

*Compliance is checked by inspection.*

**7.12.3** If the insulation of the fixed wiring supplying an appliance for permanent connection to the supply mains can come into contact with parts having temperature rise exceeding 50 K during the test of clause 11, the instructions shall state that the fixed wiring insulation must be protected, for example, by insulating sleeving having an appropriate temperature rating.

*Compliance is checked by inspection and during the test of clause 11.*



**7.12.4** The instructions for **built-in appliances** shall include information with regard to the following:

- dimensions of the space to be provided for the appliance;
- dimensions and position of the means for supporting and fixing the appliance within this space;
- minimum distances between the various parts of the appliance and the surrounding structure;
- minimum dimensions of ventilating openings and their correct arrangement;
- connection of the appliance to the supply mains and the interconnection of any separate components;
- Ⓐ) – necessity to allow disconnection of the appliance from the supply after installation, unless the appliance incorporates a switch complying with 24.3. The disconnection may be achieved by having the plug accessible or by incorporating a switch in the fixed wiring in accordance with the wiring rules. Ⓐ)

*Compliance is checked by inspection.*

**7.12.5** For appliances with **type X attachment** having a specially prepared cord, the instructions shall contain the substance of the following.

If the supply cord is damaged, it must be replaced by a special cord or assembly available from the manufacturer or its service agent.

For appliances with **type Y attachment**, the instructions shall contain the substance of the following.

If the supply cord is damaged, it must be replaced by the manufacturer, its service agent or similarly qualified persons in order to avoid a hazard.

For appliances with **type Z attachment**, the instructions shall contain the substance of the following.

The supply cord cannot be replaced. If the cord is damaged the appliance should be scrapped.

*Compliance is checked by inspection.*

Ⓐ) **7.12.6** The instructions for **heating appliances** incorporating a **non-self-resetting thermal cut-out** that is reset by disconnection of the supply mains shall contain the substance of the following:

CAUTION: In order to avoid a hazard due to inadvertent resetting of the thermal cutout, this appliance must not be supplied through an external switching device, such as a timer, or connected to a circuit that is regularly switched on and off by the utility.

*Compliance is checked by inspection.*

**7.12.7** The instructions for **fixed appliances** shall state how the appliance is to be fixed to its support.

NOTE The method of fixing is not to depend on the use of adhesives since they are not considered to be a reliable fixing means.

*Compliance is checked by inspection.* Ⓐ)

**7.12.8** The instructions for appliances connected to the water mains shall state

- the maximum inlet water pressure, in pascals;
- the minimum inlet water pressure, in pascals, if this is necessary for the correct operation of the appliance.

The instructions for appliances connected to the water mains by **detachable hose-sets** shall state that the new hose-sets supplied with the appliance are to be used and that old hose-sets should not be reused.

*Compliance is checked by inspection.*

**7.13** Instructions and other text required by this standard shall be written in an official language of the country in which the appliance is to be sold.

*Compliance is checked by inspection.*

**7.14** The markings required by the standard shall be clearly legible and durable.

*Compliance is checked by inspection and by rubbing the marking by hand for 15 s with a piece of cloth soaked with water and again for 15 s with a piece of cloth soaked with petroleum spirit.*

*After all the tests of this standard, the marking shall be clearly legible. It shall not be easily possible to remove marking plates nor shall they show curling.*

NOTE 1 In considering the durability of the marking, the effect of normal use is taken into account. For example, marking by means of paint or enamel, other than vitreous enamel, on containers that are likely to be cleaned frequently, is not considered to be durable.

NOTE 2 The petroleum spirit to be used for the test is aliphatic solvent hexane having a maximum aromatics content of 0,1 % by volume, a kauri-butanol value of 29, an initial boiling point of approximately 65 °C, a dry point of approximately 69 °C and a specific mass of approximately 0,66 kg/l.

**7.15** The markings specified in 7.1 to 7.5 shall be on a main part of the appliance.

Markings on the appliance shall be clearly discernible from the outside of the appliance but if necessary after removal of a cover. For **portable appliances** it shall be possible to remove or open this cover without the aid of a **tool**.

For **stationary appliances** at least the name or trade mark or identification mark of the manufacturer or responsible vendor and the model or type reference shall be visible when the appliance is installed as in normal use. These markings may be beneath a **detachable cover**. Other markings may be beneath a cover only if they are near to the terminals. For **fixed appliances**, this requirement applies after the appliance has been installed according to the instructions provided with the appliance.

Indications for switches and controls shall be placed on or near these components. They shall not be placed on parts which can be positioned or repositioned in such a way that the marking is misleading.

*Compliance is checked by inspection.*

**7.16** If compliance with this standard depends upon the operation of a replaceable **thermal link** or fuse link, the reference number or other means for identifying the link shall be marked at such a place that it is clearly visible when the appliance has been dismantled to the extent necessary for replacing the link.

NOTE Marking on the link is allowed as long as the marking is legible after the link has functioned.

This requirement does not apply to links which can only be replaced together with a part of the appliance.

*Compliance is checked by inspection.*

## 8 Protection against access to live parts

**8.1** Appliances shall be constructed and enclosed so that there is adequate protection against accidental contact with **live parts**.

*Compliance is checked by inspection and by the tests of 8.1.1 to 8.1.3, as applicable, taking into account 8.1.4 and 8.1.5.*

**8.1.1** *The requirement of 8.1 applies for all positions of the appliance when it is operated as in normal use, and after the removal of **detachable parts**.*

**A2** NOTE 1 **A2** This excludes the use of screw-type fuses and screw-type miniature circuit breakers which are accessible without the aid of a **tool**.

*Lamps located behind a **detachable cover** are not removed, provided that the appliance can be isolated from the supply mains by means of a plug or an all-pole switch. However, during insertion or removal of lamps which are located behind a **detachable cover**, protection against contact with **live parts** of the lamp cap shall be ensured.*

*Test probe B of IEC 61032 is applied without appreciable force, the appliance being in every possible position except that appliances normally used on the floor and having a mass exceeding 40 kg are not tilted. Through openings, the test probe is applied to any depth that the probe will permit and is rotated or angled before, during and after insertion to any position. If the opening does not allow the entry of the probe, the force on the probe in the straight position is increased to 20 N. If the probe then enters the opening, the test is repeated with the probe in the angled position.*

**A2** NOTE 2 "Without appreciable force" is considered to be a force not exceeding 1 N. **A2**

*It shall not be possible to touch **live parts** or **live parts** protected only by lacquer, enamel, ordinary paper, cotton, oxide film, beads, or sealing compound except self-hardening resins, with the probe.*

**8.1.2** *Test probe 13 of IEC 61032 is applied without appreciable force through openings in **class 0 appliances, class II appliances and class II constructions**, except for those giving access to lamp caps and **live parts** in socket-outlets.*

**A2** NOTE 1 **A2** Appliance outlets are not considered to be socket-outlets.

*The test probe is also applied through openings in earthed metal enclosures having a non-conductive coating such as enamel or lacquer.*

**A2** NOTE 2 "Without appreciable force" is considered to be a force not exceeding 1 N. **A2**

*It shall not be possible to touch **live parts** with the test probe.*

**8.1.3** Instead of test probe B and test probe 13, for appliances other than those of class II, test probe 41 of IEC 61032 is applied without appreciable force to **live parts of visibly glowing heating elements**, all poles of which can be disconnected by a single switching action. It is also applied to parts supporting such elements, provided that it is obvious from the outside of the appliance, without removing covers and similar parts, that these supporting parts are in contact with the element.

*It shall not be possible to touch these live parts.*

**A2** NOTE 1 "Without appreciable force" is considered to be a force not exceeding 1 N. **A2**

**A2** NOTE 2 **A2** For appliances provided with a supply cord and without a switching device in their supply circuit, the withdrawal of the plug from a socket-outlet is considered to be a single switching action.

**8.1.4** An **accessible part** is not considered to be live if

- the part is supplied at **safety extra-low voltage**, provided that
  - for a.c., the peak value of the voltage does not exceed 42,4 V,
  - for d.c., the voltage does not exceed 42,4 V,

or

- the part is separated from **live parts** by **protective impedance**.
- **A2** for voltages having a peak value over 15 kV, the energy in the discharge shall not exceed 350 mJ. **A2**

**A2** *The quantity of electricity and energy in the discharge is measured using a resistor having a nominal non-inductive resistance of 2 000  $\Omega$ .* **A2**

If **protective impedance** is used, the current between the part and the supply source shall not exceed 2 mA for d.c., its peak value shall not exceed 0,7 mA for a.c. and

- for voltages having a peak value over 42,4 V up to and including 450 V, the capacitance shall not exceed 0,1  $\mu\text{F}$ ,
- for voltages having a peak value over 450 V up to and including 15 kV, the discharge shall not exceed 45  $\mu\text{C}$ .

*Compliance is checked by measurement, the appliance being supplied at **rated voltage**.*

*Voltages and currents are measured between the relevant parts and each pole of the supply source. Discharges are measured immediately after the interruption of the supply. The quantity of electricity in the discharge is measured using a resistor having a nominal non-inductive resistance of 2 000  $\Omega$ .*

**A1** NOTE 1 **A1** Details of a suitable circuit for measuring the current are given in figure 4 of IEC 60990.

**A1** NOTE 2 The quantity of electricity is calculated from the sum of all areas recorded on the voltage/time graph without taking voltage polarity into account. **A1**

**8.1.5** **Live parts of built-in appliances, fixed appliances** and appliances delivered in separate units, shall be protected at least by **basic insulation** before installation or assembly.

*Compliance is checked by inspection and by the test of 8.1.1.*

**8.2 Class II appliances and class II constructions** shall be constructed and enclosed so that there is adequate protection against accidental contact with **basic insulation** and metal parts separated from **live parts** by **basic insulation** only.

It shall only be possible to touch parts which are separated from **live parts** by **double insulation** or **reinforced insulation**.

$\text{A}_2$  Compliance is checked by inspection and by applying test probe B of IEC 61032 in accordance with the conditions specified in 8.1.1.  $\text{A}_2$

$\text{A}_2$  Note deleted  $\text{A}_2$

$\text{A}_2$  NOTE  $\text{A}_2$  Built-in appliances and fixed appliances are tested after installation.

## 9 Starting of motor-operated appliances

NOTE Requirements and tests are specified in part 2 when necessary.

## 10 Power input and current

**10.1** If an appliance is marked with **rated power input**, the power input at normal operating temperature shall not deviate from the **rated power input** by more than the deviation shown in table 1.  $\text{A}_2$  The permissible deviations apply for both limits of the range for appliances marked with a **rated voltage range** having limits differing by more than 10 % of the arithmetic mean value of the range.  $\text{A}_2$

Table 1 – Power input deviation

Type of appliance	Rated power input W	Deviation
All appliances	≤25	+20 %
Heating appliances and combined appliances	>25 and ≤200	±10 %
	>200	+5 % or 20 W (whichever is the greater) –10 %
Motor-operated appliances	>25 and ≤300	+20 %
	>300	+15 % or 60 W (whichever is the greater)

The deviation for **motor-operated appliances** applies for **combined appliances** if the power input of the motors is more than 50 % of the **rated power input**.

$\text{A}_2$  NOTE  $\text{A}_2$  In case of doubt, the power input of motors may be measured separately.

*Compliance is checked by measurement when the power input has stabilized*

- *all circuits which can operate simultaneously being in operation;*
- *the appliance being supplied at **rated voltage**;*
- *the appliance being operated under **normal operation**.*

*If the power input varies throughout the operating cycle, the power input is determined as the  $\text{A}_2$  arithmetic mean value  $\text{A}_2$  of the power input occurring during a representative period.*

$\text{A}_2$  Notes deleted  $\text{A}_2$

**A2** The test is carried out at both the upper and lower limits of the ranges for appliances marked with one or more **rated voltage ranges**, unless the marking of the **rated power input** is related to the arithmetic mean value of the relevant voltage range, in which case the test is carried out at a voltage equal to the arithmetic mean value of that range. **A2**

**10.2** If an appliance is marked with **rated current**, the current at normal operating temperature shall not deviate from the **rated current** by more than the deviation shown in table 2. **A2** The permissible deviations apply for both limits of the range for appliances marked with a **rated voltage range** having limits differing by more than 10 % of the arithmetic mean value of the range. **A2**

Table 2 Current deviation

Type of appliances	Rated current A	Deviation
All appliances	≤0,2	+20 %
Heating appliances and combined appliances	>0,2 and ≤1,0	±10 %
	>1,0	+5 % or 0,10 A (whichever is the greater) -10 %
Motor-operated appliances	>0,2 and ≤1,5	+20 %
	>1,5	+15 % or 0,30 A (whichever is the greater)

The deviation for **motor-operated appliances** applies for **combined appliances** if the current of the motors is more than 50 % of the **rated current**.

**A2** NOTE **A2** In case of doubt, the current of the motors may be measured separately.

*Compliance is checked by measurement when the current has stabilized*

- all circuits which can operate simultaneously being in operation;
- the appliance being supplied at **rated voltage**;
- the appliance being operated under **normal operation**.

*If the current varies throughout the operating cycle, the current is determined as the **A2** arithmetic **A2** mean value of the current occurring during a representative period.*

**A2** The test is carried out at both the upper and lower limits of the ranges for appliances marked with one or more **rated voltage ranges**, unless the marking of the **rated current** is related to the arithmetic mean value of the relevant voltage range, in which case the test is carried out at a voltage equal to the arithmetic mean value of that range. **A2**

**A2** Notes deleted **A2**

## 11 Heating

**11.1** Appliances and their surroundings shall not attain excessive temperatures in normal use.

*Compliance is checked by determining the temperature rise of the various parts under the conditions specified in 11.2 to 11.7.*

**11.2 Hand-held appliances** are held in their normal position of use.

Appliances with pins for insertion into socket-outlets are plugged into an appropriate wall-mounted socket-outlet.

**Built-in appliances** are installed in accordance with the instructions.

Other **heating appliances** and other **combined appliances** are placed in a test corner as follows:

- appliances normally placed on a floor or table in use, are placed on the floor as near to the walls as possible;
- appliances normally fixed to a wall are fixed to one of the walls, as near to the other wall and floor or ceiling as is likely to occur, taking into account the instructions;
- appliances normally fixed to a ceiling are fixed to the ceiling as near to the walls as is likely to occur, taking into account in the instructions.

Other **motor-operated appliances** are positioned as follows:

- appliances normally placed on a floor or table in use are placed on a horizontal support;
- appliances normally fixed to a wall are fixed to a vertical support;
- appliances normally fixed to a ceiling are fixed underneath a horizontal support.

Dull black-painted plywood approximately 20 mm thick is used for the test corner, the supports and for the installation of **built-in appliances**.

For appliances provided with an automatic cord reel, one-third of the total length of the cord is unreeled. The temperature rise of the cord sheath is determined as near as possible to the hub of the reel and also between the two outermost layers of the cord on the reel.

For cord storage devices, other than automatic cord reels, which are intended to accommodate the **supply cord** partially while the appliance is in operation, 50 cm of the cord is unwound. The temperature rise of the stored part of the cord is determined at the most unfavourable place.

**11.3 Temperature rises, other than those of windings, are determined by means of fine-wire thermocouples positioned so that they have minimum effect on the temperature of the part under test.**

NOTE 1 Thermocouples having wires with a diameter not exceeding 0,3 mm are considered to be fine-wire thermocouples.

Thermocouples used for determining the temperature rise of the surface of walls, ceiling and floor of the test corner are attached to the back of small blackened disks of copper or brass, 15 mm in diameter and 1 mm thick. The front of the disk is flush with the surface of the board.

As far as is possible, the appliance is positioned so that the thermocouples detect the highest temperatures.

*The temperature rise of electrical insulation, other than that of windings, is determined on the surface of the insulation at places where failure could cause*

- a short circuit;
- contact between **live parts** and **accessible metal parts**;
- bridging of insulation;
- a reduction of **clearances** or **creepage distances** below the values specified in clause 29.

NOTE 2 If it is necessary to dismantle the appliance to position thermocouples, care has to be taken to ensure that the appliance has been correctly reassembled. In case of doubt, the power input is remeasured.

NOTE 3 The point of separation of the cores of a multicore cord and the point where insulated wires enter lampholders are examples of places where thermocouples are positioned.

*Temperature rises of windings are determined by the resistance method unless the windings are non-uniform or if it is difficult to make the necessary connections, in which case the temperature rise is determined by means of thermocouples.*

NOTE 4 The temperature rise of a winding is calculated from the formula:

$$\Delta t = \frac{R_2 - R_1}{R_1} (k + t_1) - (t_2 - t_1)$$

where

$\Delta t$  is the temperature rise of the winding;

$R_1$  is the resistance at the beginning of the test;

$R_2$  is the resistance at the end of the test;

$k$  is equal to 234,5 for copper windings and 225 for aluminium windings;

$t_1$  is the room temperature at the beginning of the test;

$t_2$  is the room temperature at the end of the test.

At the beginning of the test, the windings are to be at room temperature. It is recommended that the resistance of windings at the end of the test be determined by taking resistance measurements as soon as possible after switching off and then at short intervals so that a curve of resistance against time can be plotted for ascertaining the resistance at the instant of switching off.

**11.4 Heating appliances are operated under normal operation and at 1,15 times rated power input.**

**11.5 Motor-operated appliances are operated under normal operation and supplied with the most unfavourable voltage between 0,94 times and 1,06 times the rated voltage.**

**11.6 Combined appliances are operated under normal operation and supplied with the most unfavourable voltage between 0,94 times and 1,06 times the rated voltage.**

**11.7 The appliance is operated for a duration corresponding to the most unfavourable conditions of normal use.**

NOTE The duration of the test may consist of more than one cycle of operation.

**11.8 During the test, the temperature rises are monitored continuously and shall not exceed the values shown in table 3. However, if the temperature rise of the motor winding exceeds the value specified in table 3 or if there is doubt with regard to the temperature classification of the insulation of the motor, the tests of annex C are carried out.**

**Protective devices shall not operate and sealing compound shall not flow out.**  $\square_{A1}$  However, components in **protective electronic circuits** are allowed to operate provided they are tested for the number of cycles of operation specified in 24.1.4.  $\square_{A1}$



Table 3 – Maximum normal temperature rises

Part	Temperature rise K
<p>Windings <sup>a</sup>, if the winding insulation according to IEC 60085 is:</p> <p><b>A<sub>2</sub></b> – class 105                      – class 120                      – class 130                      – class 155                      – class 180 <b>A<sub>2</sub></b>                      – class 200                      – class 220                      – class 250</p>	<p>75 (65)                      90 (80)                      95 (85)                      115                      140                      160                      180                      210</p>
<p>Pins of appliance inlets:</p> <p>– for very hot conditions                      – for hot conditions                      – for cold conditions</p>	<p>130                      95                      45</p>
<p>Terminals, including earthing terminals, for external conductors of <b>stationary appliances</b>, unless they are provided with a <b>supply cord</b></p>	<p>60</p>
<p>Ambient of switches, <b>thermostats</b> and <b>temperature limiters</b> <sup>b</sup>:</p> <p>– without T-marking                      – with T-marking</p>	<p>30                      T-25</p>
<p><b>A<sub>2</sub></b> Rubber, polychloroprene or polyvinyl chloride insulation of internal and external wiring, including <b>supply cords</b>:</p> <p>– without temperature rating or with a temperature rating not exceeding 75 °C                      – with temperature rating (T) <sup>j</sup> where T exceeds 75 °C</p>	<p>50                      T-25 <b>A<sub>2</sub></b></p>
<p>Cord sheaths used as <b>supplementary insulation</b></p>	<p>35</p>
<p>Sliding contacts of cord reels</p>	<p>65</p>
<p>Points where the insulation of wires can come into contact with parts of a terminal block or compartment for fixed wiring, for a <b>stationary appliance</b> not provided with a <b>supply cord</b>.</p>	<p>50 <sup>c</sup></p>
<p>Rubber, other than synthetic, used for gaskets or other parts, the deterioration of which could affect safety:</p> <p>– when used as <b>supplementary insulation</b> or as <b>reinforced insulation</b>                      – in other cases</p>	<p>40                      50</p>
<p>Lampholders with T-marking <sup>d</sup></p> <p>– B15 and B22 marked T1                      – B15 and B22 marked T2                      – other lampholders</p> <p>Lampholders without T-marking <sup>d</sup></p> <p>– E14 and B15                      – B22, E26 and E27                      – other lampholders and starter holders for fluorescent lamps</p>	<p>140                      185                      T-25                      110                      140                      55</p>

<http://www.china-gauges.com/>

Table 3 (continued)

Part	Temperature rise
<p>Material used as insulation, other than that specified for wires and windings <sup>e</sup>:</p> <ul style="list-style-type: none"> <li>– impregnated or varnished textile, paper or press-board</li> <li>– laminates bonded with: <ul style="list-style-type: none"> <li>• melamine-formaldehyde, phenol-formaldehyde or phenol-furfural resins</li> <li>• urea-formaldehyde resin</li> </ul> </li> <li>– printed circuit boards bonded with epoxy resin</li> <li>– moulding of: <ul style="list-style-type: none"> <li>• phenol-formaldehyde with cellulose fillers</li> <li>• phenol-formaldehyde with mineral fillers</li> <li>• melamine-formaldehyde</li> <li>• urea-formaldehyde</li> </ul> </li> <li>– polyester with glass reinforcement</li> <li>– silicone rubber</li> <li>– polytetrafluoroethylene</li> <li>– pure mica and tightly sintered ceramic material when such materials are used as <b>supplementary insulation or reinforced insulation</b></li> <li>– thermoplastic material <sup>f</sup></li> </ul>	<p>70</p> <p>85 (175) 65 (150)</p> <p>120</p> <p>85 (175) 100 (200) 75 (150) 65 (150)</p> <p>110</p> <p>145</p> <p>265</p> <p>400</p> <p>–</p>
<p>Wood, in general <sup>g</sup></p> <ul style="list-style-type: none"> <li>– Wooden supports, walls, ceiling and floor of the test corner and wooden cabinet: <ul style="list-style-type: none"> <li>• <b>stationary appliances</b> liable to be operated continuously for long periods</li> <li>• other appliances</li> </ul> </li> </ul>	<p>65</p> <p>60 65</p>
<p>Outer surface of capacitors <sup>h</sup>:</p> <ul style="list-style-type: none"> <li>– with marking of maximum operating temperature (T) <sup>i</sup></li> <li>– without marking of maximum operating temperature: <ul style="list-style-type: none"> <li>• small ceramic capacitors for radio and television interference suppression</li> <li>• capacitors complying with IEC 60384-14</li> <li>• other capacitors</li> </ul> </li> </ul>	<p>T-25</p> <p>50 50 20</p>
<p>External enclosure of <b>motor-operated appliances</b>, except handles held in normal use</p>	<p>60</p>
<p>Surfaces of handles, knobs, grips and similar parts which are continuously held in normal use (e.g. soldering irons)</p> <ul style="list-style-type: none"> <li>– of metal</li> <li>– of porcelain or vitreous material</li> <li>– of moulded material, rubber or wood</li> </ul>	<p>30 40 50</p>
<p>Surfaces of handles, knobs, grips and similar parts which are held for short periods only in normal use (e.g. switches):</p> <ul style="list-style-type: none"> <li>– of metal</li> <li>– of porcelain or vitreous material</li> <li>– of moulded material, rubber or wood</li> </ul>	<p>35 45 60</p>
<p>Parts in contact with oil having a flash-point of t °C</p>	<p>t-50</p>

Table 3 (continued)

NOTE 1 If other materials than those mentioned in the table are used, they are not to be subjected to temperatures in excess of their thermal capabilities as determined by ageing tests.

NOTE 2 The values in the table are based on an ambient temperature not normally exceeding 25 °C but occasionally reaching 35 °C. However, the temperature rise values specified are based on 25 °C.

NOTE 3 The temperature rise limit for metal applies to parts having a metal coating at least 0,1 mm thick and to metal parts having a plastic coating less than 0,3 mm thick.

NOTE 4 The temperature of the terminals of switches is measured if the switch is tested in accordance with annex H.

<sup>a</sup> To allow for the fact that the average temperature of windings of universal motors, relays, solenoids and similar components is usually above the temperature at the points on the windings where thermocouples are placed, the figures without parentheses apply when the resistance method is used and those within parentheses apply when thermocouples are used. For windings of vibrator coils and a.c. motors, the figures without parentheses apply in both cases.

For motors constructed so that the circulation of air between the inside and the outside of the case is prevented but which are not necessarily sufficiently enclosed to be considered airtight, the temperature rise limits may be increased by 5 K.

<sup>A2</sup> The temperature rise limit of windings in transformers and inductors mounted on printed circuit boards is equal to the thermal class of the winding insulation reduced by 25 K provided the largest dimension of the winding does not exceed 5 mm in cross section or length. <sup>A2</sup>

<sup>b</sup> *T* means the maximum ambient temperature in which the component or its switch head can operate.

The ambient is the temperature of the air at the hottest point at a distance of 5 mm from the surface of the component concerned. However, if a **thermostat** or a **temperature limiter** is mounted on a heat-conducting part, the declared temperature limit of the mounting surface (*T<sub>s</sub>*) is also applicable. Therefore, the temperature rise of the mounting surface has to be measured.

<sup>A1</sup> The temperature rise limit does not apply to switches or controls tested in accordance with the conditions occurring in the appliance. <sup>A1</sup>

<sup>c</sup> This limit may be exceeded if the instruction specified in 7.12.3 is supplied.

<sup>d</sup> Locations for measuring the temperature rises are specified in table 12.1 of IEC 60598-1.

<sup>e</sup> The values in parentheses apply to locations where the part is fixed to a hot surface.

<sup>f</sup> There is no specific limit for thermoplastic material. However, the temperature rise has to be determined in order that the tests of 30.1 can be carried out.

<sup>g</sup> The limit specified concerns the deterioration of wood and it does not take into account deterioration of surface finishes.

<sup>h</sup> There is no limit for the temperature rise of capacitors that are short-circuited in 19.11.

<sup>i</sup> Temperature marking for capacitors mounted on printed circuit boards may be given in the technical sheet.

<sup>A2</sup> <sup>j</sup> IEC 60245 Types 53, 57 and 87 **supply cords** have a *T* rating of 60 °C;

IEC 60227 Types 52 and 53 **supply cords** have a *T* rating of 70 °C;

IEC 60227 Types 56 and 57 **supply cords** have a *T* rating of 90 °C. <sup>A2</sup>

## 12 Void

## 13 Leakage current and electric strength at operating temperature

13.1 At operating temperature, the leakage current of the appliance shall not be excessive and its electric strength shall be adequate.

Compliance is checked by the tests of 13.2 and 13.3.

The appliance is operated under **normal operation** for the duration specified in 11.7.

**Heating appliances** are operated at 1,15 times the **rated power input**.

**Motor-operated appliances and combined appliances** are supplied at 1,06 times rated voltage.

Three-phase appliances which, according to the instructions for installation, are also suitable for single-phase supply are tested as single-phase appliances with the three circuits connected in parallel.

**Protective impedance** and radio interference filters are disconnected before carrying out the tests.

**13.2** The leakage current is measured by means of the circuit described in figure 4 of IEC 60990 between any pole of the supply and **accessible metal parts** connected to metal foil having an area not exceeding 20 cm × 10 cm which is in contact with **accessible surfaces** of insulating materials.

NOTE 1 The voltmeter shown in figure 4 of IEC 60990 is to be capable of measuring the true r.m.s. value of the voltage.

For single-phase appliances, the measuring circuit is shown in the following figures:

- if of **class II**, figure 1;
- if other than **class II**, figure 2.

The leakage current is measured with the selector switch in each of the positions a and b.

For three-phase appliances, the measuring circuit is shown in the following figures:

- if of **class II**, figure 3;
- if other than **class II**, figure 4.

For three-phase appliances, the leakage current is measured with the switches a, b and c in the closed position. The measurements are then repeated with each of the switches a, b and c open in turn, the other two switches remaining closed. For appliances intended to be connected in star connection only, the neutral is not connected.

After the appliance has been operated for a duration as specified in 11.7, the leakage current shall not exceed the following values:

- |   |   |
|---|---|
| – for <b>class II appliances</b>                          | 0,25 mA   |
| – for <b>class 0, class 0I and class III appliances</b>   | 0,5 mA  |
| – for <b>portable class I appliances</b>                  | 0,75 mA   |
| – for <b>stationary class I motor-operated appliances</b> | 3,5 mA  |
| – for <b>stationary class I heating appliances</b>        | 0,75 mA or 0,75 mA per kW <b>rated power input</b> of the appliance with a maximum of 5 mA, whichever is higher |

For **combined appliances**, the total leakage current may be within the limits specified for **heating appliances** or **motor-operated appliances**, whichever is the greater, but the two limits are not added.

If the appliance incorporates capacitors and is provided with a single-pole switch, the measurements are repeated with the switch in the **off position**.

If the appliance incorporates a thermal control which operates during the test of clause 11 the leakage current is measured immediately before the control opens the circuit.

NOTE 2 The test with the switch in the **off position** is carried out to verify that capacitors connected behind a single-pole switch do not cause an excessive leakage current.

NOTE 3 It is recommended that the appliance is supplied through an isolating transformer, otherwise it is to be insulated from earth.

NOTE 4 The metal foil has the largest area possible on the surface under test without exceeding the dimensions specified. If its area is smaller than the surface under test, it is not to test all parts of the surface.

The heat dissipation of the appliance is not to be affected by the metal foil.

**13.3**  $\square_{A1}$  The appliance is disconnected from the supply and the insulation is immediately subjected to a voltage having a frequency of 50 Hz or 60 Hz for 1 min, in accordance with IEC 61180-1.

The high-voltage source used for the test is to be capable of supplying a short circuit current  $I_s$  between the output terminals after the output voltage has been adjusted to the appropriate test voltage. The overload release of the circuit is not to be operated by any current below the tripping current  $I_r$ . The values of  $I_s$  and  $I_r$  are given in Table 5 for various high-voltage sources.  $\square_{A1}$

The test voltage is applied between **live parts** and **accessible parts**, non-metallic parts being covered with metal foil. For **class II constructions** having intermediate metal between **live parts** and **accessible parts**, the voltage is applied across the **basic insulation** and the **supplementary insulation**.

NOTE 1 Care should be taken to avoid overstressing the components of **electronic circuits**.

The values of the test voltages are specified in table 4.

$\square_{A1}$  Table 4 – Voltage for electric strength test

Insulation	Test voltage V			
	Rated voltage <sup>a</sup>			Working voltage (U)
	SELV	≤150 V	>150 V and ≤250 V <sup>b</sup>	
<b>Basic insulation</b>	500	1 000	1 000	1,2 U + 700
<b>Supplementary insulation</b>		1 250	1 750	1,2 U + 1 450
<b>Reinforced insulation</b>		2 500	3 000	2,4 U + 2 400

<sup>a</sup> For multi-phase appliances, the line to neutral or line to earth voltage is used for **rated voltage**. The test voltage for 480 V multi-phase appliances is that specified for a **rated voltage** in the range > 150 V and ≤ 250 V.

<sup>b</sup> For appliances having a **rated voltage** ≤ 150 V, these test voltages apply to parts having a **working voltage** > 150 V ≤ 250 V.

$\square_{A1}$

$\square_{A1}$  Text deleted  $\square_{A1}$

No breakdown shall occur during the test.

NOTE 2 Glow discharges without drop in voltage are neglected.

$\square_{A1}$  Note deleted  $\square_{A1}$

**A1** Table 5 – Characteristics of high-voltage sources

Test voltage V	Minimum current mA	
	$I_s$	$I_{sc}$
≤4 000	200	100
>4 000 and ≤10 000	50	40
>10 000 and ≤20 000	40	20

NOTE The currents are calculated on the basis of the short circuit and release energies of 300 VA and 400 VA respectively at the upper end of the voltage ranges.

**A1**

## 14 Transient overvoltages

Appliances shall withstand the transient overvoltages to which they may be subjected.

Compliance is checked by subjecting each **clearance** having a value less than those specified in table 16 to an impulse voltage test.

**A2** The impulse test voltage has a no-load waveshape corresponding to the 1,2/50  $\mu$ s standard impulse specified in IEC 61180-1. It is supplied from a generator having a conventional impedance not exceeding 42  $\Omega$ . The impulse test voltage is applied three times for each polarity with intervals of at least 1 s. **A2**

NOTE 1 The generator is specified in IEC 61180-2.

The impulse test voltage is specified in table 6 for **rated impulse voltages** given in table 15.

**A1** Table 6 – Impulse test voltage

Rated impulse voltage V	Impulse test voltage V
330	350
500	550
800	910
1 500	1 750
2 500	2 950
4 000	4 800
6 000	7 300
8 000	9 800
10 000	12 300

**A1**

*There shall be no flashover. However, flashover of **functional insulation** is allowed if the appliance complies with clause 19 when the **clearance** is short-circuited.*

**A1** NOTE 2 The impulse test voltages have been calculated using correction factors for testing at locations situated at sea level. It is considered that they are appropriate for any location between sea level and 500 m. If tests are carried out at other locations, other correction factors should be used as noted in subclause 4.1.1.2.1.2 of IEC 60664-1. **A1**

**A2** Note deleted **A2**

## 15 Moisture resistance

**15.1** The enclosure of the appliance shall provide the degree of protection against moisture in accordance with the classification of the appliance.

*Compliance is checked as specified in 15.1.1 taking into account 15.1.2, the appliance not being connected to the supply mains.*

*The appliance shall then withstand the electric strength test of 16.3 and inspection shall show that there is no trace of water on insulation which could result in a reduction of **clearances** and **creepage distances** below the values specified in clause 29.*

NOTE The external enclosure is carefully wiped to remove any surplus water before inspection. Care has to be taken when dismantling to avoid displacing any water within the appliance.

**15.1.1** Appliances other than those classified IPX0 are subjected to the tests of IEC 60529 as follows:

- IPX1 appliances as described in subclause 14.2.1;
- IPX2 appliances as described in subclause 14.2.2;
- IPX3 appliances as described in subclause 14.2.3a;
- IPX4 appliances as described in subclause 14.2.4a;
- IPX5 appliances as described in subclause 14.2.5;
- IPX6 appliances as described in subclause 14.2.6;
- IPX7 appliances as described in subclause 14.2.7. For this test the appliance is immersed in water containing approximately 1 % NaCl.

NOTE The **hand-held spray nozzle** may be used for testing appliances that cannot be placed under the oscillating tube specified in IEC 60529.

**A1** Water valves containing **live parts** and that are incorporated in external hoses for connection of an appliance to the water mains are subjected to the test specified for IPX7 appliances. **A1**

**15.1.2 Hand-held appliances** are turned continuously through the most unfavourable positions during the test.

**Built-in appliances** are installed in accordance with the instructions.

*Appliances normally used on the floor or table are placed on a horizontal unperforated support having a diameter of twice the oscillating tube radius minus 15 cm.*

*Appliances normally fixed to a wall and appliances with pins for insertion into socket-outlets are mounted as in normal use in the centre of a wooden board having dimensions which are 15 cm ± 5 cm in excess of those of the orthogonal projection of the appliance on the board. The wooden board is placed at the centre of the oscillating tube.*

*For IPX3 appliances, the base of wall-mounted appliances is placed at the same level as the pivot axis of the oscillating tube.*

*For IPX4 appliances, the horizontal centre line of the appliance is aligned with the pivot axis of the oscillating tube. However, for appliances normally used on the floor or table, the movement is limited to two times 90° from the vertical for a period of 5 min, the support being placed at the level of the pivot axis of the oscillating tube.*

*If the instructions for wall-mounted appliances state that the appliance is to be placed close to the floor level and specifies a distance, a board is placed under the appliance at that distance. The dimensions of the board are 5 cm more than the horizontal projection of the appliance.*

**A1)** *Appliances normally fixed to a ceiling are mounted underneath a horizontal unperforated support that is constructed to prevent water spraying onto its top surface. The pivot axis of the oscillating tube is located at the same level as the underside of the support and aligned centrally with the appliance. The spray is directed upwards.*

*For IPX4 appliances, the movement of the tube is limited to two times 90° from the vertical for a period of 5 min. **A1)***

*Appliances with **type X attachment**, except those having a specially prepared cord, are fitted with the lightest permissible type of flexible cord of the smallest cross-sectional area specified in table 13.*

**Detachable parts** are removed and subjected, if necessary, to the relevant treatment with the main part. However, if the instructions state that a part has to be removed for **user maintenance** and a **tool** is needed, this part is not removed.

**15.2** Appliances subject to spillage of liquid in normal use shall be constructed so that such spillage does not affect their electrical insulation.

*Compliance is checked by the following test.*

*Appliances with **type X attachment**, except those having a specially prepared cord, are fitted with the lightest permissible type of flexible cord of the smallest cross-sectional area specified in table 13.*

*Appliances incorporating an appliance inlet are tested with or without an appropriate connector in position, whichever is most unfavourable.*

**Detachable parts** are removed.

*The liquid container of the appliance is completely filled with water containing approximately 1 % NaCl and a further quantity, equal to 15 % of the capacity of the container or 0,25 l, whichever is the greater, is poured in steadily over a period of 1 min.*

*The appliance shall then withstand the electric strength test of 16.3 and inspection shall show that there is no trace of water on insulation that could result in a reduction of **clearances** or **creepage distances** below the values specified in clause 29.*



**15.3** Appliances shall be proof against humid conditions that may occur in normal use.

*Compliance is checked by the following test.*

*Appliances that were subjected to the tests of 15.1 or 15.2 are placed in normal ambient conditions for 24 h.*

*Cable entries, if any, are left open. If knock-outs are provided, one of them is opened. **Detachable parts** are removed and subjected, if necessary, to the humidity test with the main part.*

*The humidity test is carried out for 48 h in a humidity cabinet containing air with a relative humidity of  $(93 \pm 3) \%$ . The temperature of the air is maintained within 1 K of any convenient value  $t$  between  $20 \text{ }^\circ\text{C}$  and  $30 \text{ }^\circ\text{C}$ . Before being placed in the humidity cabinet, the appliance is brought to a temperature of  $t_0^{+4} \text{ }^\circ\text{C}$ .*

NOTE 1 In most cases, the appliance may be brought to the specified temperature by keeping it at this temperature for at least 4 h before the humidity test.

NOTE 2 A relative humidity of  $(93 \pm 3) \%$  can be obtained by placing a saturated solution of  $\text{Na}_2\text{SO}_4$  or  $\text{KNO}_3$  in water in the humidity cabinet, the container having a sufficiently large contact surface with the air.

NOTE 3 The specified conditions may be achieved by ensuring a constant circulation of the air within a thermally insulated cabinet.

*The appliance shall then withstand the tests of clause 16 in the humidity cabinet or in the room in which the appliance was brought to the prescribed temperature after reassembly of those parts that may have been removed.*

## **16 Leakage current and electric strength**

**16.1** The leakage current of the appliance shall not be excessive and its electric strength shall be adequate.

*Compliance is checked by the tests of 16.2 and 16.3.*

**Protective impedance is disconnected from live parts before carrying out the tests.**

*The tests are carried out on the appliance at room temperature and not connected to the supply mains.*

**16.2** An a.c. test voltage is applied between **live parts** and **accessible metal parts** that are connected to metal foil having an area not exceeding  $20 \text{ cm} \times 10 \text{ cm}$  in contact with **accessible surfaces** of insulating materials.

*The test voltage is*

- 1,06 times **rated voltage**, for single-phase appliances;
- 1,06 times **rated voltage**, divided by  $\sqrt{3}$ , for three-phase appliances.

*The leakage current is measured within 5 s after the application of the test voltage.*

The leakage current shall not exceed the following values:

- for **class II appliances** 0,25 mA
- for **class 0, class 0I and class III appliances** 0,5 mA
- for **portable class I appliances** 0,75 mA
- for **stationary class I motor-operated appliances** 3,5 mA
- for **stationary class I heating appliances** 0,75 mA or 0,75 mA per kW **rated power input** of the appliance with a maximum of 5 mA, whichever is higher

The values specified above are doubled if all controls have an **off position** in all poles. They are also doubled if

- the appliance has no control other than a **thermal cut-out**, or
- all **thermostats, temperature limiters** and energy regulators do not have an **off position**, or
- the appliance has radio interference filters. In this case the leakage current with the filter disconnected shall not exceed the limits specified.

For **combined appliances**, the total leakage current may be within the limits specified for **heating appliances** or **motor-operated appliances**, whichever is the greater, but the two limits are not added.

**A2** 16.3 Immediately after the test of 16.2, the insulation is subjected to a voltage having a frequency of 50 Hz or 60 Hz for 1 min in accordance with IEC 61180-1. The values of the test voltage for different types of insulation are given in Table 7. **A2**

**Accessible parts** of insulating material are covered with metal foil.

NOTE 1 Care is to be taken that the metal foil is placed so that no flashover occurs at the edges of the insulation.

**A1** Table 7 – Test voltages

Insulation	Test voltage V			
	Rated voltage <sup>a</sup>			Working voltage (U)
	SELV	≤150 V	>150 V and ≤250 V <sup>b</sup>	>250 V
<b>Basic insulation</b>	500	1 250	1 250	1,2 U + 950
<b>Supplementary insulation</b>	–	1 250	1 750	1,2 U + 1 450
<b>Reinforced insulation</b>	–	2 500	3 000	2,4 U + 2 400

<sup>a</sup> For multi-phase appliances, the line to neutral or line to earth voltage is used for **rated voltage**. The test voltage for 480 V multi-phase appliances is that specified for a **rated voltage** in the range > 150 V and ≤ 250 V.

<sup>b</sup> For appliances having a **rated voltage** ≤ 150 V, these test voltages apply to parts having a **working voltage** > 150 V and ≤ 250 V.

**A1**

*A test voltage is applied between **accessible metal parts** and the **supply cord** which is wrapped with metal foil where it is located in an inlet bushing, a cord guard or a cord anchorage, any clamping screws being tightened to two-thirds of the torque specified in table 14. The test voltage is 1 250 V for **class 0 appliances** and **class I appliances** and 1 750 V for **class II appliances**.*

**A2** NOTE 2 The characteristics of the high-voltage source used for the test are described in Table 5. **A2**

NOTE 3 For **class II constructions** incorporating both **reinforced insulation** and **double insulation**, care is to be taken that the voltage applied to the **reinforced insulation** does not overstress the **basic insulation** or the **supplementary insulation**.

NOTE 4 In constructions where **basic insulation** and **supplementary insulation** cannot be tested separately, the insulation is subjected to the test voltages specified for **reinforced insulation**.

NOTE 5 When testing insulating coatings, the metal foil may be pressed against the insulation by means of a sandbag so that the pressure is approximately 5 kPa. The test may be limited to places where the insulation is likely to be weak, for example where there are sharp metal edges under the insulation.

NOTE 6 If practicable, insulating linings are tested separately.

NOTE 7 Care is to be taken to avoid overstressing the components of **electronic circuits**.

**A2** Text deleted **A2**

*No breakdown shall occur during the test.*

## 17 Overload protection of transformers and associated circuits

Appliances incorporating circuits supplied from a transformer shall be constructed so that in the event of short circuits which are likely to occur in normal use, excessive temperatures do not occur in the transformer or in the circuits associated with the transformer.

NOTE 1 Examples are the short-circuiting of bare or inadequately insulated conductors of **accessible circuits** operating at **safety extra-low voltage**.

NOTE 2 Failure of **basic insulation** is not considered likely to occur in normal use.

*Compliance is checked by applying the most unfavourable short circuit or overload which is likely to occur in normal use, the appliance being supplied with 1,06 times or 0,94 times **rated voltage**, whichever is the more unfavourable.*

*The temperature rise of the insulation of the conductors of **safety extra-low voltage** circuits shall not exceed the relevant value specified in table 3 by more than 15 K.*

*The temperature of windings shall not exceed the values specified in table 8. However, these limits do not apply to fail-safe transformers complying with subclause 15.5 of IEC 61558-1.*

## 18 Endurance

NOTE Requirements and tests are specified in part 2 when necessary.

## 19 Abnormal operation

**19.1** Appliances shall be constructed so that as a result of abnormal or careless operation, the risk of fire, mechanical damage impairing safety or protection against electric shock is obviated as far as is practicable.

**Electronic circuits** shall be designed and applied so that a fault condition will not render the appliance unsafe with regard to electric shock, fire hazard, mechanical hazard or **Ⓐ1** dangerous malfunction. **Ⓐ1**

*Appliances incorporating heating elements are subjected to the tests of 19.2 and 19.3. In addition, such appliances having a control that limits the temperature during clause 11 are subjected to the tests of 19.4 and, when applicable, to the test of 19.5. Appliances incorporating PTC heating elements are also subjected to the test of 19.6.*

*Appliances incorporating motors are subjected to the tests of 19.7 to 19.10, as applicable.*

*Appliances incorporating electronic circuits are also subjected to the tests of 19.11 and 19.12, as applicable.*

**Ⓐ2** *Appliances incorporating contactors or relays are subjected to the test of 19.14. **Ⓐ2***

*Unless otherwise specified, the tests are continued until a **non-self-resetting thermal cut-out** operates or until steady conditions are established. If a heating element or an intentionally weak part becomes permanently open-circuited, the relevant test is repeated on a second sample. This second test shall be terminated in the same mode unless the test is otherwise satisfactorily completed.*

NOTE 1 An intentionally weak part is a part intended to rupture under conditions of abnormal operation to prevent the occurrence of a condition which could impair compliance with this standard. Such a part may be a replaceable component, such as a resistor or a capacitor or a part of a component to be replaced, such as an inaccessible **thermal link** incorporated in a motor.

NOTE 2 Fuses, **thermal cut-outs**, overcurrent protection devices, or similar devices incorporated in the appliance, may be used to provide the necessary protection. The **protective device** in the fixed wiring does not provide the necessary protection.

*Unless otherwise specified, only one abnormal condition is simulated at any one time.*

NOTE 3 If more than one of the tests are applicable to the same appliance, these tests are carried out consecutively after the appliance has cooled down to room temperature.

NOTE 4 For **combined appliances**, the tests are carried out with motors and heating elements operating simultaneously under **normal operation**, the appropriate tests being applied one at a time to each motor and heating element.

NOTE 5 When it is stated that a control is short-circuited, it may be rendered inoperative instead.

*Unless otherwise specified, compliance with the tests of this clause is checked as described in 19.13.*

**19.2** *Appliances with heating elements are tested under the conditions specified in clause 11 but with restricted heat dissipation. The supply voltage, determined prior to the test, is that required to provide a power input of 0,85 times **rated power input** under **normal operation** when the power input has stabilized. This voltage is maintained throughout the test.*

**Ⓐ1** NOTE Controls that operate during the test of Clause 11 are allowed to operate. **Ⓐ1**

**19.3** *The test of 19.2 is repeated but with a supply voltage, determined prior to the test, equal to that required to provide a power input of 1,24 times **rated power input** under **normal operation** when the power input has stabilized. This voltage is maintained throughout the test.*

**Ⓐ1** NOTE Controls that operate during the test of Clause 11 are allowed to operate. **Ⓐ1**

**19.4** The appliance is tested under the conditions specified in clause 11. Any control that limits the temperature during the test of clause 11 is short-circuited.

NOTE If the appliance incorporates more than one control, they are short-circuited in turn.

**19.5** The test of 19.4 is repeated on **class 01 appliances** and **class I appliances** incorporating tubular sheathed or embedded heating elements. However, controls are not short-circuited but one end of the element is connected to the sheath of the heating element.

This test is repeated with the polarity of the supply to the appliance reversed and with the other end of the element connected to the sheath.

The test is not carried out on appliances intended to be permanently connected to fixed wiring and on appliances where an **all-pole disconnection** occurs during the test of 19.4.

NOTE 1 Appliances with a neutral are tested with the neutral connected to the sheath.

NOTE 2 For embedded heating elements, the metal enclosure is considered to be the sheath.

**19.6** Appliances with **PTC heating elements** are supplied at **rated voltage** until steady conditions with regard to power input and temperature are established.

The **working voltage** of the **PTC heating element** is increased by 5 % and the appliance is operated until steady conditions are re-established. The voltage is then increased in similar steps until 1,5 times **working voltage** is reached, or until the **PTC heating element** ruptures, whichever occurs first.

**19.7** The appliance is operated under stalled conditions by

- locking the rotor if the locked rotor torque is smaller than the full load torque;
- locking moving parts of other appliances.

NOTE 1 If an appliance has more than one motor, the test is carried out for each motor separately.

**A1** NOTE 2 Void. **A1**

Appliances incorporating motors and having capacitors in the circuit of an auxiliary winding, are operated with the rotor locked, the capacitors being open-circuited one at a time. The test is repeated with the capacitors short-circuited one at a time unless they are of class P2 of **A2** IEC 60252-1. **A2**

NOTE 3 This test is carried out with the rotor locked since some motors may start thus giving rise to inconsistent results.

For each of the tests, appliances provided with a timer or programmer are supplied at **rated voltage** for a period equal to the maximum period allowed by the timer or programmer.

Other appliances are supplied at **rated voltage** for a period

- of 30 s for
  - **hand-held appliances**,
  - appliances that have to be kept switched on by hand or foot, and
  - appliances that are continuously loaded by hand;
- of 5 min for other appliances that are operated while extended;
- until steady conditions are established, for other appliances.

NOTE 4 Appliances that are tested for 5 min are indicated in the relevant part 2.

During the test, the temperature of the windings shall not exceed the relevant value specified in table 8.

**Table 8 – Maximum winding temperature**

Type of appliance	Temperature °C							
	Class A	Class E	Class B	Class F	Class H	Class 200	Class 220	Class 250
Appliances other than those operated until steady conditions are established	200	215	225	240	260	280	300	330
Appliances operated until steady conditions are established								
– if impedance protected	150	165	175	190	210	230	250	280
– if protected by a <b>protective device</b>								
• during the first hour, maximum value	200	215	225	240	260	280	300	330
• after the first hour, maximum value	175	190	200	215	235	255	275	305
• after the first hour, arithmetic average	150	165	175	190	210	230	250	280

**19.8** One phase of appliances incorporating three-phase motors is disconnected. The appliance is then operated under **normal operation** and supplied at **rated voltage** for the period specified in 19.7.

**19.9** A running overload test is carried out on appliances incorporating motors that are intended to be remotely or automatically controlled or liable to be operated continuously.

The appliance is operated under **normal operation** and supplied at **rated voltage** until steady conditions are established. The load is then increased so that the current through the motor windings is raised by 10 % and the appliance is operated again until steady conditions are established, the supply voltage being maintained at its original value. The load is again increased and the test is repeated until the **protective device** operates or the motor stalls.

*During the test the winding temperature shall not exceed*

- 140 °C, for class A winding insulation;
- 155 °C, for class E winding insulation;
- 165 °C, for class B winding insulation;
- 180 °C, for class F winding insulation;
- 200 °C, for class H winding insulation;
- 220 °C, for class 200 winding insulation;
- 240 °C, for class 220 winding insulation;
- 270 °C, for class 250 winding insulation.

NOTE If the load cannot be increased in appropriate steps, the motor is removed from the appliance and tested separately.

**A1** Note deleted **A1**

**19.10** Appliances incorporating series motors are operated with the lowest possible load and supplied at 1,3 times **rated voltage** for 1 min.

*During the test, parts shall not be ejected from the appliance.*

**19.11 Electronic circuits** are checked by evaluation of the fault conditions specified in 19.11.2 for all circuits or parts of circuits, unless they comply with the conditions specified in 19.11.1.

NOTE 1 In general, examination of the appliance and its circuit diagram will reveal the fault conditions which have to be simulated, so that testing can be limited to those cases that may be expected to give the most unfavourable results.

**A2** Appliances incorporating an **electronic circuit** are subjected to the tests of 19.11.3 and 19.11.4.

Appliances incorporating an **electronic circuit** that relies upon a programmable component to function correctly are subjected to the test of 19.11.4.8, unless restarting at any point in the operating cycle after interruption of operation due to a supply voltage dip will not result in a hazard. The test is carried out after removal of all batteries and other components intended to maintain the programmable component supply voltage during mains supply voltage dips, interruptions and variations. **A2**

**A1** Appliances having a **A2** device **A2** with an **off position** obtained by electronic disconnection or a **A2** device **A2** that can place the appliance in a stand-by mode, are subjected to the tests of 19.11.4. **A1**

**A1** NOTE 1a The sequence of tests for the evaluation of **electronic circuits** is given in Annex Q. **A1**

*If the safety of the appliance under any of the fault conditions depends on the operation of a miniature fuse-link complying with IEC 60127, the test of 19.12 is carried out.*

*During and after each test, the temperature of the windings shall not exceed the values specified in table 8. However, these limits do not apply to fail-safe transformers complying with subclause 15.5 of IEC 61558-1. The appliance shall comply with the conditions specified in 19.13. Any current flowing through **protective impedance** shall not exceed the limits specified in 8.1.4.*

NOTE 2 Unless it is necessary to replace components after any of the tests, the electric strength test required by 19.13 need only be carried out after the final test on the **electronic circuit**.

If a conductor of a printed circuit board becomes open-circuited, the appliance is considered to have withstood the particular test, provided  $\text{A}_2$  both  $\text{A}_2$  of the following conditions are met:

- the base material of the printed circuit board withstands the test of annex E;
- any loosened conductor does not reduce **clearances** or **creepage distances** between live parts and **accessible metal parts** below the values specified in clause 29.

$\text{A}_2$  List item deleted  $\text{A}_2$

**19.11.1** Fault conditions a) to f) specified in 19.11.2 are not applied to circuits or parts of circuits when both of the following conditions are met:

- the **electronic circuit** is a low-power circuit as described below;
- protection against electric shock, fire hazard, mechanical hazard or  $\text{A}_1$  **dangerous malfunction**  $\text{A}_1$  of other parts of the appliance does not rely on the correct functioning of the **electronic circuit**.

An example of a low-power circuit is shown in figure 6 and is determined as follows.

The appliance is supplied at **rated voltage** and a variable resistor, adjusted to its maximum resistance, is connected between the point to be investigated and the opposite pole of the supply source. The resistance is then decreased until the power consumed by the resistor reaches a maximum. Points closest to the supply source at which the maximum power delivered to this resistor does not exceed 15 W at the end of 5 s are called low-power points. The part of the circuit farther from the supply source than a low-power point is considered to be a low-power circuit.

NOTE 1 The measurements are made from only one pole of the supply source, preferably the one that gives the fewest low-power points.

NOTE 2 When determining the low-power points, it is recommended to start with points close to the supply source.

NOTE 3 The power consumed by the variable resistor is measured by a wattmeter.

**19.11.2** The following fault conditions are considered and, if necessary, applied one at a time, consequential faults being taken into consideration:

- a) short circuit of **functional insulation** if **clearances** or **creepage distances** are less than the values specified in clause 29;
- b) open circuit at the terminals of any component;
- c) short circuit of capacitors, unless they comply with IEC 60384-14;
- d) short circuit of any two terminals of an **electronic component**, other than an integrated circuit. This fault condition is not applied between the two circuits of an optocoupler;
- e) failure of triacs in the diode mode;
- f) failure of an integrated circuit.  $\text{A}_1$  Text deleted  $\text{A}_1$  All possible output signals are considered for faults occurring within the integrated circuit. If it can be shown that a particular output signal is unlikely to occur, then the relevant fault is not considered.

NOTE 1 Components such as thyristors and triacs are not subjected to fault condition f).

NOTE 2 Microprocessors are tested as integrated circuits.

$\text{A}_2$  g) failure of an electronic power switching device in a partial turn-on mode with loss of gate (base) control. During this test, winding temperatures shall not exceed the values given in 19.7.

NOTE 3 This mode may be simulated by disconnecting the electronic power switching device gate (base) terminal and connecting an external adjustable power supply between the gate (base) terminal and the source (emitter) terminal of the electronic power switching device. The power supply is then varied so as to achieve a current that will not damage the electronic power switching device but give the most onerous conditions of test.

NOTE 4 Examples of electronic power switching devices are field effect transistors (FET's and MOSFET's) and bipolar transistors (including IGBT's).  $\text{A}_2$



Fault condition f) is applied to encapsulated and similar components if the circuit cannot be assessed by other methods.

Positive temperature coefficient resistors are not short-circuited if they are used within the manufacturer's specification. However, PTC-S thermistors are short-circuited unless they comply with IEC 60738-1.

In addition, each low-power circuit is short-circuited by connecting the low-power point to the pole of the supply source from which the measurements were made.

For simulation of the fault conditions, the appliance is operated under the conditions specified in clause 11 but supplied at rated voltage.

When any of the fault conditions are simulated, the duration of the test is

- as specified in 11.7 but only for one operating cycle and only if the fault cannot be recognized by the user, for example, a change in temperature;
- as specified in 19.7, if the fault can be recognized by the user, for example, when the motor of a kitchen machine stops;
- until steady conditions are established, for circuits continuously connected to the supply mains, for example, stand-by circuits.

**A1** In each case, the test is ended if a non-self-resetting interruption of the supply occurs within the appliance. **A1**

**19.11.3** If the appliance incorporates a **protective electronic circuit** which operates to ensure compliance with clause 19, the relevant test is repeated with a single fault simulated, as indicated in a) to f) of 19.11.2.

**A1** **19.11.4** Appliances having a **A2** device **A2** with an **off position** obtained by electronic disconnection, or a **A2** device **A2** that can be placed in the stand-by mode, are subjected to the tests of 19.11.4.1 to 19.11.4.7. The tests are carried out with the appliance supplied at **rated voltage**, the **A2** device **A2** being set in the **off position** or in the stand-by mode.

Appliances incorporating a **protective electronic circuit** are subjected to the tests of 19.11.4.1 to 19.11.4.7. The tests are carried out after the **protective electronic circuit** has operated during the relevant tests of Clause 19 except 19.2, 19.6 and 19.11.3. However, appliances that are operated for 30 s or 5 min during the test of 19.7 are not subjected to the tests for electromagnetic phenomena.

The tests are carried out with surge **A2** protective devices **A2** disconnected, unless they incorporate spark gaps.

NOTE 1 If the appliance has several modes of operation, the tests are carried out with the appliance operating in each mode, if necessary.

NOTE 2 Appliances incorporating electronic controls complying with the IEC 60730 series are not exempt from the tests.

**19.11.4.1** The appliance is subjected to electrostatic discharges in accordance with IEC 61000-4-2, test level 4 being applicable. Ten discharges having a positive polarity and ten discharges having a negative polarity are applied at each preselected point. **A1**

**A1** 19.11.4.2 The appliance is subjected to radiated fields in accordance with IEC 61000-4-3 test level 3 being applicable.

NOTE The dwell time for each frequency is to be sufficient to observe a possible malfunction of the protective electronic circuit.

19.11.4.3 The appliance is subjected to fast transient bursts in accordance with IEC 61000-4-4. Test level 3 is applicable for signal and control lines. Test level 4 is applicable for the power supply lines. The bursts are applied for 2 min with a positive polarity and for 2 min with a negative polarity.

19.11.4.4 The power supply terminals of the appliance are subjected to voltage surges in accordance with IEC 61000-4-5, five positive impulses and five negative impulses being applied at the selected points. Test level 3 is applicable for the line-to-line coupling mode, a generator having a source impedance of 2  $\Omega$  being used. Test level 4 is applicable for the line-to-earth coupling mode, a generator having a source impedance of 12  $\Omega$  being used.

Earthed heating elements in **class I appliances** are disconnected during this test.

NOTE If a feedback system depends on inputs related to a disconnected heating element, an artificial network may be needed.

For appliances having surge arresters incorporating spark gaps, the test is repeated at a level that is 95 % of the flashover voltage.

19.11.4.5 The appliance is subjected to injected currents in accordance with IEC 61000-4-6, test level 3 being applicable. During the test, all frequencies between 0,15 MHz to 80 MHz are covered.

NOTE The dwell time for each frequency is to be sufficient to observe a possible malfunction of the protective electronic circuit.

19.11.4.6 **A2** The appliance is subjected to the Class 3 voltage dips and interruptions in accordance with IEC 61000-4-11. The values specified in Table 1 and Table 2 of IEC 61000-4-11 are applied at zero crossing of the supply voltage. **A2**

19.11.4.7 The appliance is subjected to mains signals in accordance with IEC 61000-4-13, test level class 2 being applicable. **A1**

**A2** 19.11.4.8 The appliance is supplied at **rated voltage** and operated under **normal operation**. After approximately 60 s, the power supply voltage is reduced to a level such that the appliance ceases to respond to user inputs or parts controlled by the programmable component cease to operate, whichever occurs first. This value of supply voltage is recorded. The appliance is supplied at **rated voltage** and operated under **normal operation**. The voltage is then reduced to a value of approximately 10 % less than the recorded voltage. It is held at this value for approximately 60 s and then increased to **rated voltage**. The rate of decrease and increase of the power supply voltage is to be approximately 10 V/s.

The appliance shall continue to either operate normally from the same point in its operating cycle at which the voltage decrease occurred or a manual operation shall be required to restart it. **A2**

19.12 If safety of the appliance depends upon the operation of a miniature fuse-link complying with IEC 60127 during any of the fault conditions specified in 19.11.2, the test is repeated but with the miniature fuse-link replaced by an ammeter. If the current measured

- does not exceed 2,1 times the rated current of the fuse-link, the circuit is not considered to be adequately protected and the test is carried out with the fuse-link short-circuited;
- is at least 2,75 times the rated current of the fuse-link, the circuit is considered to be adequately protected;

- is between 2,1 times and 2,75 times the rated current of the fuse-link, the fuse link is short-circuited and the test is carried out
  - for the relevant period or for 30 min, whichever is the shorter, for quick acting fuse-links;
  - for the relevant period or for 2 min, whichever is the shorter, for time lag fuse-links.

NOTE 1 In case of doubt, the maximum resistance of the fuse-link has to be taken into account when determining the current.

NOTE 2 The verification whether the fuse-link acts as a protective device is based on the fusing characteristics specified in IEC 60127, which also gives the information necessary to calculate the maximum resistance of the fuse-link.

NOTE 3 Other fuses are considered to be intentionally weak parts in accordance with 19.1.

**19.13** During the tests the appliance shall not emit flames, molten metal, or poisonous or ignitable gas in hazardous amounts and temperature rises shall not exceed the values shown in table 9.

**A2** After the tests, and when the appliance has cooled to approximately room temperature, compliance with Clause 8 shall not be impaired and the appliance shall comply with 20.2 if it can still be operated. **A2**

**Table 9 – Maximum abnormal temperature rise**

<b>Part</b>	<b>Temperature rise K</b>
Wooden supports, walls, ceiling and floor of the test corner and wooden cabinets <sup>a</sup>	150
Insulation of the <b>supply cord</b> <sup>a</sup>	150
<b>Supplementary insulation and reinforced insulation</b> other than thermoplastic materials <sup>b</sup>	1,5 times the relevant value specified in table 3
<sup>a</sup> For <b>motor-operated appliances</b> these temperature rises are not determined.	
<sup>b</sup> There is no specific limit for <b>supplementary insulation and reinforced insulation</b> of thermoplastic material. However, the temperature rise has to be determined so that the test of 30.1 can be carried out.	

When the insulation, other than that of **class III appliances**, has cooled down to approximately room temperature, it shall withstand the electric strength test of 16.3, the test voltage, however, being as specified in table 4.

NOTE The humidity treatment of 15.3 is not applied before this electric strength test.

For appliances which are immersed in or filled with conducting liquid in normal use, the appliance is immersed in or filled with water for 24 h before the electric strength test is carried out.

**A1** The appliance shall not undergo a **dangerous malfunction**, and there shall be no failure of **protective electronic circuits** if the appliance is still operable. **A1**

**A2** After the operation or interruption of a control, **clearances and creepage distances** across the **functional insulation** shall withstand the electric strength test of 16.3, the test voltage, however, being twice the **working voltage**. **A2**

**A2** Appliances tested with an electronic switch in the **off position**, or in the stand-by mode shall

- not become operational, or
- if they become operational, not result in a **dangerous malfunction** during or after the tests of 19.11.4.

NOTE Unintended operation that may impair safety can result from careless use of appliances, such as:

- storage of small appliances while connected to the supply;
- placing flammable material on working surfaces of heating appliances; or
- placing objects in areas near motorized appliances that are not expected to start. **A2**

**A2** **19.14** Appliances are operated under the conditions of Clause 11. Any contactor or relay contact that operates under the conditions of Clause 11 is short-circuited.

NOTE If a relay or contactor with more than one contact is used, all contacts are short-circuited at the same time. **A2**

## 20 Stability and mechanical hazards

**20.1** Appliances, other than **fixed appliances** and **hand-held appliances**, intended to be used on a surface such as the floor or a table shall have adequate stability.

*Compliance is checked by the following test, appliances incorporating an appliance inlet being fitted with an appropriate connector and flexible cord.*

*The appliance is placed in any normal position of use on a plane inclined at an angle of 10° to the horizontal, the **supply cord** resting on the inclined plane in the most unfavourable position. However, if part of an appliance comes into contact with the horizontal supporting surface when the appliance is tilted through an angle of 10°, the appliance is placed on a horizontal support and tilted in the most unfavourable direction through an angle of 10°.*

NOTE 1 The appliance is not connected to the supply mains.

NOTE 2 The test on the horizontal support may be necessary for appliances provided with rollers, castors or feet.

NOTE 3 Castors or wheels are blocked to prevent the appliance from rolling.

*Appliances provided with doors are tested with the doors open or closed, whichever is the more unfavourable.*

*Appliances intended to be filled with liquid by the user in normal use are tested empty or filled with the most unfavourable quantity of water up to the capacity indicated in the instructions.*

*The appliance shall not overturn.*

*The test is repeated on appliances with heating elements with the angle of inclination increased to 15°. If the appliance overturns in one or more positions, it is subjected to the tests of clause 11 in each of these overturned positions.*

*During this test, temperature rises shall not exceed the values shown in table 9.*

**20.2** Moving parts of appliances shall, as far as is compatible with the use and working of the appliance, be positioned or enclosed to provide adequate protection against personal injury in normal use.

NOTE 1 For some appliances complete protection is impracticable, for example sewing machines, food mixers and electric knives.

Protective enclosures, guards and similar parts shall be **non-detachable parts** and shall have adequate mechanical strength.

NOTE 2 Enclosures that can be opened by overriding an interlock by applying the test probe are considered to be **detachable parts**.

The unexpected reclosure of **self-resetting thermal cut-outs** and overcurrent **protective devices** shall not cause a hazard.

NOTE 3 Examples of appliances in which **self-resetting thermal cut-outs** and overcurrent **protective devices** could cause a hazard are food mixers and wringers.

*Compliance is checked by inspection, by the tests of  $\text{A}_1$  21.1  $\text{A}_1$  and by applying a force not exceeding 5 N by means of a test probe that is similar to test probe B of IEC 61032 but having a circular stop face with a diameter of 50 mm, instead of the non-circular face.*

*For appliances provided with movable devices such as those intended for varying the tension of belts, the test with the test probe is carried out with these devices adjusted to the most unfavourable position within their range of adjustment. If necessary, belts are removed.*

*It shall not be possible to touch dangerous moving parts with this test probe.*

## 21 Mechanical strength

$\text{A}_1$  21.1  $\text{A}_1$  Appliances shall have adequate mechanical strength and be constructed to withstand such rough handling that may be expected in normal use.

$\text{A}_1$  *Compliance is checked by applying blows to the appliance in accordance with test Ehb of IEC 60068-2-75, the spring hammer test.*

*The appliance is rigidly supported and three blows, having an impact energy of 0,5 J, are applied to every point of the enclosure that is likely to be weak.  $\text{A}_1$*

$\text{A}_1$  NOTE 1 Void.  $\text{A}_1$

*If necessary, the blows are also applied to handles, levers, knobs and similar parts and to signal lamps and their covers but only if the lamps or covers protrude from the enclosure by more than 10 mm or if their surface area exceeds 4 cm<sup>2</sup>. Lamps within the appliance and their covers are only tested if they are likely to be damaged in normal use.*

NOTE 2 When applying the release cone to the guard of a **visibly glowing heating element**, care is to be taken that the hammer head passing through the guard does not strike the heating element.

*After the test, the appliance shall show no damage that could impair compliance with this standard and compliance with 8.1, 15.1 and clause 29 shall not be impaired. In case of doubt, **supplementary insulation** and **reinforced insulation** are subjected to the electric strength test of 16.3.*

NOTE 3 Damage to the finish, small dents that do not reduce **clearances** or **creepage distances** below the values specified in clause 29, and small chips that do not adversely affect protection against access to **live parts** or moisture, are ignored.

NOTE 4 If a decorative cover is protected by an inner cover, fracture of the decorative cover is ignored if the inner cover itself withstands the test.

If there is doubt as to whether a defect has occurred by the application of the preceding blows, this defect is neglected and the group of three blows is applied to the same place on a new sample which shall then withstand the test.

NOTE 5 Cracks not visible to the naked eye and surface cracks in fibre-reinforced materials and similar materials are ignored.

**A1** 21.2 Accessible parts of solid insulation shall have sufficient strength to prevent penetration by sharp implements.

Compliance is checked by subjecting the insulation to the following test, unless the thickness of **supplementary insulation** is at least 1 mm and that of **reinforced insulation** is at least 2 mm.

The insulation is raised to the temperature measured during the test of Clause 11. The surface of the insulation is then scratched by means of a hardened steel pin, the end of which has the form of a cone with an angle of 40°. Its tip is rounded with a radius of 0,25 mm ± 0,02 mm. The pin is held at an angle of 80° – 85° to the horizontal and loaded so that the force exerted along its axis is 10 N ± 0,5 N. The scratches are made by drawing the pin along the surface of the insulation at a speed of approximately 20 mm/s. Two parallel scratches are made. They are spaced sufficiently apart so that they are not affected by each other, their length covering approximately 25 % of the length of the insulation. Two similar scratches are made at 90° to the first pair without crossing them.

The test fingernail of Figure 7 is then applied to the scratched surface with a force of approximately 10 N. No further damage, such as separation of the material, shall occur. The insulation shall then withstand the electric strength test of 16.3.

The hardened steel pin is then applied perpendicularly with a force of 30 N ± 0,5 N to an unscratched part of the surface. The insulation shall then withstand the electric strength test of 16.3 with the pin still applied and used as one of the electrodes. **A1**

## 22 Construction

**22.1** If the appliance is marked with the first numeral of the IP system, the relevant requirements of IEC 60529 shall be fulfilled.

Compliance is checked by the relevant tests.

**22.2** For **stationary appliances**, means shall be provided to ensure **all-pole disconnection** from the supply mains. Such means shall be one of the following:

- a **supply cord** fitted with a plug;
- a switch complying with 24.3;
- a statement in the instructions that a disconnection incorporated in the fixed wiring is to be provided;
- an appliance inlet.

**A2** Single-pole switches and single-pole **protective devices** that disconnect heating elements from the supply mains in single-phase, permanently connected **class 01 appliances** and **class I appliances** shall be connected to the phase conductor. **A2**

Compliance is checked by inspection.

**22.3** Appliances with pins for insertion into socket-outlets shall not impose undue strain on these socket-outlets. The means for retaining the pins shall withstand the forces to which the pins are likely to be subjected in normal use.

*Compliance is checked by inserting the pins of the appliance into a socket-outlet without earthing contact. The socket-outlet has a horizontal pivot at a distance of 5 mm behind the engagement face of the socket-outlet and in the plane of the contact faces.*

*The torque that has to be applied to maintain the engagement face of the socket-outlet in the vertical plane shall not exceed 0,25 Nm.*

NOTE The torque to keep the socket-outlet itself in the vertical plane is not included in this value.

*A new sample of the appliance is firmly held so that the retention of the pins is not affected. The appliance is placed in a heating cabinet for 1 h at a temperature of  $70\text{ °C} \pm 2\text{ °C}$ . The appliance is then removed from the heating cabinet and a pull force of 50 N is immediately applied for 1 min to each pin along their longitudinal axes.*

*When the appliance has cooled down to room temperature, the pins shall not have been displaced by more than 1 mm.*

*Each pin is then subjected in turn to a torque of 0,4 Nm, which is applied for 1 min in each direction. The pins shall not rotate unless rotation does not impair compliance with this standard.*

**22.4** Appliances for heating liquids and appliances causing undue vibration shall not be provided with pins for insertion into socket-outlets.

*Compliance is checked by inspection.*

**22.5** Appliances intended to be connected to the supply mains by means of a plug shall be constructed so that in normal use there is no risk of electric shock from charged capacitors  $A_2$  having a rated capacitance exceeding  $0,1\text{ }\mu\text{F}$   $A_2$  when the pins of the plug are touched.

$A_2$  Note deleted  $A_2$

$A_1$  Compliance is checked by the following test.

*The appliance is supplied at **rated voltage**. Any switch is then placed in the **off position** and the appliance is disconnected from the supply mains at the instant of voltage peak. One second after disconnection, the voltage between the pins of the plug is measured with an instrument that does not appreciably affect the value to be measured.*

*The voltage shall not exceed 34 V.  $A_1$*

**22.6** Appliances shall be constructed so that their electrical insulation cannot be affected by water that could condense on cold surfaces or by liquid that could leak from containers, hoses, couplings and similar parts of the appliance. The electrical insulation of **class II appliances** and **class II constructions** shall not be affected if a hose ruptures or a seal leaks.

*Compliance is checked by inspection and, in case of doubt, by the following test.*

*Drops of coloured water solution are applied by a syringe to parts inside the appliance where leakage of a liquid could occur and affect electrical insulation. The appliance is in operation or at rest, whichever is the more unfavourable.*

*After this test, inspection shall show that there is no trace of liquid on windings or insulation that could result in a reduction of **creepage distances** below the values specified in 29.2.*

**22.7** Appliances containing liquid or gases in normal use or having steam-producing devices shall incorporate adequate safeguards against the risk of excessive pressure.

*Compliance is checked by inspection and, if necessary, by an appropriate test.*

**22.8** For appliances having compartments to which access can be gained without the aid of a **tool** and that are likely to be cleaned in normal use, the electrical connections shall be arranged so that they are not subject to pulling during cleaning.

*Compliance is checked by inspection and by manual test.*

**22.9** Appliances shall be constructed so that parts such as insulation, internal wiring, windings, commutators and slip rings are not exposed to oil, grease or similar substances, unless the substance has adequate insulating properties so that compliance with the standard is not impaired.

*Compliance is checked by inspection and by the tests of this standard.*

**22.10** <sup>[A1]</sup> It shall not be possible to reset voltage-maintained **non-self-resetting thermal cut-outs** by the operation of an automatic switching device incorporated within the appliance.

NOTE 1 Voltage-maintained controls will automatically reset if they become de-energized.

Non-self-resetting thermal motor protectors shall have a trip-free action unless they are voltage maintained.

NOTE 2 Trip-free is an automatic action that is independent of manipulation or position of the actuating member.

Reset buttons of non-self-resetting controls shall be located or protected so that their accidental resetting is unlikely to occur if this could result in a hazard.

NOTE 3 For example, this requirement precludes the location of reset buttons on the back of an appliance, which could result in them being reset by pushing the appliance against a wall.

*Compliance is checked by inspection.* <sup>[A1]</sup>

**22.11 Non-detachable parts** that protect against access to **live parts**, moisture or contact with moving parts shall be fixed in a reliable manner and withstand the mechanical stress occurring during normal use. Snap-in devices used for fixing such parts shall have an obvious locked position. The fixing properties of snap-in devices used in parts that are likely to be removed during installation or servicing shall be reliable.

*Compliance is checked by the following tests.*

*Parts that are likely to be removed during installation or servicing are disassembled and assembled 10 times before the test is carried out.*

NOTE Servicing includes replacement of the **supply cord**.

*The test is carried out at room temperature. However, if compliance may be affected by the temperature of the appliance, the test is also carried out immediately after it has been operated under the conditions specified in clause 11.*

*The test is applied to all parts that are likely to be detachable whether or not they are fixed by screws, rivets or similar parts.*



A force is applied without jerks for 10 s in the most unfavourable direction to parts likely to be weak. The force is as follows:

- push force, 50 N;
- pull force:
  - if the shape of the part is such that the fingertips cannot easily slip off, 50 N;
  - if the projection of the part that is gripped is less than 10 mm in the direction of removal, 30 N.

The push force is applied by test probe 110 EC 61032.

The pull force is applied by suitable means, such as a suction cup, so that the test results are not affected. While the force is being applied, the test fingernail of figure 7 is inserted in any aperture or joint with a force of 10 N. The fingernail is then slid sideways with a force of 10 N but is not twisted or used as a lever.

If the shape of the part is such that an axial pull is unlikely, the pull force is not applied but the test fingernail is inserted in any aperture or joint with a force of 10 N and is then pulled for 10 s by means of the loop with a force of 30 N in the direction of removal.

If the part is likely to be twisted, the following torque is applied at the same time as the pull or push force:

- 2 Nm, for major dimensions up to 50 mm;
- 4 Nm, for major dimensions over 50 mm.

This torque is also applied when the test fingernail is pulled by means of the loop.

If the projection of the part which is gripped is less than 10 mm, the torque is reduced by 50 %.

Parts shall remain in the locked position and not become detached.

**22.12** Handles, knobs, grips, levers and similar parts shall be fixed in a reliable manner so that they will not work loose in normal use if loosening could result in a hazard. If these parts are used to indicate the position of switches or similar components, it shall not be possible to fix them incorrectly if this could result in a hazard.

Compliance is checked by inspection, by manual test and by trying to remove the part by applying an axial force of

- 15 N, if an axial pull is unlikely to be applied in normal use;
- 30 N, if an axial pull is likely to be applied in normal use.

The force is applied for 1 min.

NOTE Sealing compound and similar materials, other than self-hardening resins, are not considered to be adequate to prevent loosening.

**22.13** Appliances shall be constructed so that when handles are gripped in normal use, contact is unlikely between the operator's hand and parts having a temperature rise exceeding the value specified in table 3 for handles which are held for short periods only in normal use.

Compliance is checked by inspection and, if necessary, by determining the temperature rise.

**22.14** Appliances shall have no ragged or sharp edges, other than those necessary for the functioning of the appliance, that could create a hazard for the user in normal use or during **user maintenance**.

Pointed ends of self-tapping screws or other fasteners shall be located so that they are unlikely to be touched by the user in normal use or during **user maintenance**.

*Compliance is checked by inspection.*

**22.15** Storage hooks and similar devices for flexible cords shall be smooth and well-rounded.

*Compliance is checked by inspection.*

**22.16** Automatic cord reels shall be constructed so that they do not cause

- undue abrasion or damage to the sheath of the flexible cord;
- breakage of conductor strands;
- undue wear of contacts.

*Compliance is checked by the following test, which is carried out without passing current through the flexible cord.*

*Two-thirds of the length of the cord is unreeled. If the withdrawable length of the cord is less than 225 cm, the cord is unreeled so that a length of 75 cm remains on the reel. An additional length of 75 cm of the cord is then unreeled and pulled in a direction so that the greatest abrasion occurs to the sheath, taking into account the normal position of use of the appliance. Where the cord leaves the appliance, the angle between the axis of the cord during the test and the axis of the cord when it is unreeled without substantial resistance is approximately 60°. The cord is allowed to be recoiled by the reel.*

NOTE 1 If the cord does not recoil at the angle of 60°, this angle is adjusted to the maximum that will allow recoil.

*The test is carried out 6 000 times at a rate of approximately 30 times per minute or at the maximum rate allowed by the construction of the cord reel if this is less.*

NOTE 2 It may be necessary to interrupt the test to allow the cord to cool.

*After this test, the cord and cord reel are inspected. In case of doubt the cord is subjected to the electric strength test of 16.3, a test voltage of 1 000 V being applied between the conductors of the cord connected together and metal foil wrapped around the cord.*

**22.17** Spacers intended to prevent the appliance from overheating walls shall be fixed so that it is not possible to remove them from the outside of the appliance by hand or by means of a screwdriver or a spanner.

*Compliance is checked by inspection and by manual test.*

**22.18** Current-carrying parts and other metal parts, the corrosion of which could result in a hazard, shall be resistant to corrosion under normal conditions of use.

NOTE 1 Stainless steel and similar corrosion-resistant alloys and plated steel are considered to be satisfactory for the purpose of this requirement.

*Compliance is checked by verifying that after the tests of clause 19, the relevant parts show no sign of corrosion.*

NOTE 2 Attention is to be paid to the compatibility of the materials of terminals and to the effect of heating.

**22.19** Driving belts shall not be relied upon to provide the required level of insulation unless they are constructed to prevent inappropriate replacement.

*Compliance is checked by inspection.*

**22.20** Direct contact between **live parts** and thermal insulation shall be effectively prevented unless such material is non-corrosive, non-hygroscopic and non-combustible.

NOTE Glass-wool is an example of thermal insulation which is satisfactory for the purpose of this requirement. Non-impregnated slag-wool is an example of corrosive thermal insulation.

*Compliance is checked by inspection and, if necessary, by appropriate tests.*

**22.21** Wood, cotton, silk, ordinary paper and similar fibrous or hygroscopic material shall not be used as insulation, unless impregnated. <sup>(A2)</sup> This requirement does not apply to magnesium oxide and mineral ceramic fibres used for the electrical insulation of heating elements. <sup>(A2)</sup>

<sup>(A2)</sup> NOTE <sup>(A2)</sup> Insulating material is considered to be impregnated if the interstices between the fibres of the material are substantially filled with a suitable insulant.

<sup>(A2)</sup> Note deleted <sup>(A2)</sup>

*Compliance is checked by inspection.*

**22.22** Appliances shall not contain asbestos.

*Compliance is checked by inspection.*

**22.23** Oils containing polychlorinated biphenyl (PCB) shall not be used in appliances.

*Compliance is checked by inspection.*

**22.24** Bare heating elements shall be supported so that the heating conductor is unlikely to come into contact with **accessible metal parts** if they rupture.

*Compliance is checked by inspection after cutting the heating conductor in the most unfavourable place.*

NOTE 1 No force is applied to the conductor after it has been cut.

NOTE 2 This test is carried out after the tests of clause 29.

**22.25** Appliances, other than those of **class III**, shall be constructed so that sagging heating conductors cannot come into contact with **accessible metal parts**.

*Compliance is checked by inspection.*

NOTE This requirement may be met by providing **supplementary insulation** or a core which effectively prevents the heating conductor from sagging.

**22.26** <sup>(A1)</sup> Appliances <sup>(A1)</sup> having parts of **class III construction** shall be constructed so that the insulation between parts operating at **safety extra-low voltage** and other **live parts** complies with the requirements for **double insulation** or **reinforced insulation**.

*Compliance is checked by the tests specified for **double insulation** or **reinforced insulation**.*

**22.27** Parts connected by **protective impedance** shall be separated by **double insulation** or **reinforced insulation**.

*Compliance is checked by the tests specified for **double insulation** or **reinforced insulation**.*

**22.28** For **class II appliances** connected in normal use to the gas mains or to the water mains, metal parts conductively connected to the gas pipes or in contact with the water shall be separated from **live parts** by **double insulation** or **reinforced insulation**.

*Compliance is checked by inspection.*

**22.29** **Class II appliances** intended to be permanently connected to fixed wiring shall be constructed so that the required degree of access to **live parts** is maintained after installation.

NOTE The protection against access to **live parts** may be affected, for example, by the installation of metal conduits or cables provided with a metal sheath.

*Compliance is checked by inspection.*

**22.30** Parts of **class II construction** which serve as **supplementary insulation** or **reinforced insulation**, and which could be omitted during reassembly after servicing, shall be

- fixed so that they cannot be removed without being seriously damaged,
- or
- constructed so that they cannot be replaced in an incorrect position and if they are omitted, the appliance is rendered inoperable or manifestly incomplete.

NOTE Servicing includes replacement of components such as **supply cords** and switches.

*Compliance is checked by inspection and by manual test.*

**22.31** **Clearances** and **creepage distances** over **supplementary insulation** and **reinforced insulation** shall not be reduced below the values specified in clause 29 as a result of wear. If a part, such as a wire, screw, nut or spring, becomes loose or falls out of position, **clearances** and **creepage distances** between **live parts** and **accessible parts** shall not be reduced below the values specified for **supplementary insulation**.

NOTE For the purpose of this requirement

- only the normal position of use of the appliance is taken into account;
- it is not to be expected that two independent fixings will become loose at the same time;
- parts fixed by means of screws or nuts and locking washers are not regarded as liable to become loose, provided that these screws or nuts are not required to be removed during the replacement of the **supply cord** or other servicing;
- wires connected by soldering are not considered to be adequately fixed unless they are held in place near the terminals independently of the solder;
- wires connected to terminals are not considered to be adequately secured unless an additional fixing is provided near the terminal, so that in the case of stranded conductors, the fixing clamps both the insulation and conductor;
- short rigid wires are not regarded as liable to be dislodged from a terminal if they remain in position when the terminal screw is loosened.

*Compliance is checked by inspection, by measurement and by manual test.*

**22.32 Supplementary insulation** and **reinforced insulation** shall be constructed or protected so that the deposition of pollution resulting from wear of parts within the appliance does not reduce **clearances** or **creepage distances** below the values specified in clause 29.

Parts of natural or synthetic rubber used as **supplementary insulation** shall be resistant to ageing or be located and dimensioned so that **creepage distances** are not reduced below the values specified in 29.2, even if cracks occur.

Ceramic material which is not tightly sintered, similar materials or beads alone shall not be used as **supplementary insulation** or **reinforced insulation**.

**A2** Insulating material in which heating conductors are embedded is considered to be **basic insulation** and not **reinforced insulation**. **A2**

**A2** Note deleted **A2**

*Compliance is checked by inspection and by measurement.*

*If the rubber part has to be resistant to ageing, the following test is carried out.*

*The part is suspended freely in an oxygen bomb, the effective capacity of the bomb being at least 10 times the volume of the part. The bomb is filled with oxygen not less than 97 % pure, to a pressure of 2,1 MPa ± 0,07 MPa and maintained at a temperature of 70 °C ± 1 °C.*

**A2** NOTE **A2** The use of the oxygen bomb presents some danger unless handled with care. Precautions should be taken to avoid the risk of explosion due to sudden oxidation.

*The part is kept in the bomb for 96 h. It is then removed from the bomb and left at room temperature out of direct sunlight for at least 16 h.*

*The part is then examined and shall show no crack visible to the naked eye.*

*In case of doubt, the following test is carried out to determine if ceramic material is tightly sintered.*

*The ceramic material is broken into pieces that are immersed in a solution containing 1 g of fuchsine in each 100 g of methylated spirit. The solution is maintained at a pressure not less than 15 MPa for a period so that the product of the test duration in hours and the test pressure in megapascals is approximately 180.*

*The pieces are removed from the solution, rinsed, dried and broken into smaller pieces.*

*The freshly broken surfaces are examined and shall not show any trace of dye visible to the naked eye.*

**22.33** Conductive liquids that are or may become accessible in normal use shall not be in direct contact with **live parts**. Electrodes shall not be used for heating liquids.

For **class II construction**, conductive liquids that are or may become accessible in normal use shall not be in direct contact with **basic insulation** or **reinforced insulation**.

For **class II construction**, conductive liquids which are in contact with **live parts** shall not be in direct contact with **reinforced insulation**.

NOTE 1 Liquids that are in contact with unearthed **accessible metal parts** are considered to be accessible.

NOTE 2 An air layer is not considered to be sufficient as one of the layers of **double insulation** if it is likely to be bridged by leaking liquid.

*Compliance is checked by inspection.*

**22.34** Shafts of operating knobs, handles, levers and similar parts shall not be live unless the shaft is inaccessible when the part is removed.

*Compliance is checked by inspection and by applying the test probe as specified in 8.1 after removal of the part even with the aid of a tool.*

**A2) 22.35** For constructions other than those of **class III**, handles, levers and knobs that are held or actuated in normal use shall not become live in the event of a failure of **basic insulation**. If these handles, levers and knobs are of metal and if their shafts or fixings are likely to become live in the event of a failure of **basic insulation**, they shall be adequately covered by insulating material or their **accessible parts** shall be separated from their shafts or fixings by **supplementary insulation**. **A2)**

NOTE The insulating material is considered to be adequate if it complies with the electric strength test of 16.3 for **supplementary insulation**

For **stationary appliances** this requirement does not apply to handles, levers and knobs, other than those of electrical components, provided that they are reliably connected to an earthing terminal or earthing contact or separated from **live parts** by earthed metal.

*Compliance is checked by inspection and if necessary by the relevant tests.*

**22.36** For appliances other than those of **class III**, handles which are continuously held in the hand in normal use shall be constructed so that when gripped in normal use, the operator's hand is not likely to touch metal parts unless they are separated from **live parts** by **double insulation** or **reinforced insulation**.

*Compliance is checked by inspection.*

**22.37** For **class II appliances**, capacitors shall not be connected to **accessible metal parts** and their casings, if of metal, shall be separated from **accessible metal parts** by **supplementary insulation**.

This requirement does not apply to capacitors complying with the requirements for **protective impedance** specified in 22.42.

*Compliance is checked by inspection and by the relevant tests.*

**22.38** Capacitors shall not be connected between the contacts of a **thermal cut-out**.

*Compliance is checked by inspection.*

**22.39** Lampholders shall be used only for the connection of lamps.

*Compliance is checked by inspection.*

**22.40 Motor-operated appliances and combined appliances** which are intended to be moved while in operation, or which have **accessible moving parts** shall be fitted with a switch to control the motor. The actuating member of this switch shall be easily visible and accessible.

**A2** Unless the appliance can operate continuously, automatically or remotely without giving rise to a hazard, appliances for **remote operation** shall be fitted with a switch for stopping the operation of the appliance. The actuating member of this switch shall be easily visible and accessible.

NOTE Examples of appliances that can operate continuously, automatically or remotely without giving rise to a hazard are fans, storage water heaters, air conditioners, refrigerators and drives for awnings, windows, doors, gates and rolling shutters. **A2**

*Compliance is checked by inspection.*

**22.41** Appliances shall not incorporate components, other than lamps, containing mercury.

*Compliance is checked by inspection.*

**22.42 Protective impedance** shall consist of at least two separate components whose impedance is unlikely to change significantly during the lifetime of the appliance. If any one of the components is short-circuited or open-circuited the values specified in 8.1.4 shall not be exceeded.

NOTE Resistors complying with test a) of subclause 14.1 of IEC 60065 and class Y capacitors complying with IEC 60384-14 are considered to be components having a sufficiently stable impedance.

*Compliance is checked by inspection and by measurement.*

**22.43** Appliances which can be adjusted for different voltages shall be constructed so that accidental changing of the setting is unlikely to occur.

*Compliance is checked by manual test.*

**A2 22.44** Appliances shall not have an enclosure that is shaped or decorated like a toy.

NOTE Examples of such enclosures are those representing animals, characters, persons or scale models.

*Compliance is checked by inspection. **A2***

NOTE Examples are enclosures representing animals or persons or resembling scale models.

**22.45** When air is used as **reinforced insulation**, the appliance shall be constructed so that **clearances** cannot be reduced below the values specified in 29.1.3 due to deformation as a result of an external force applied to the enclosure.

NOTE 1 A sufficiently rigid construction is considered to meet this requirement.

NOTE 2 Deformation due to manhandling the appliance has to be taken into account.

*Compliance is checked by inspection and by manual test.*

**A1** 22.46 Software used in **protective electronic circuits** shall be **software class B** or **software class C**.

NOTE 1 Failure of **software class B** in the presence of another fault in the appliance, or failure of **software class C** alone, could result in **dangerous malfunction**, electric shock, fire, mechanical or other hazards. Software class A denotes software used for functional purposes.

*Compliance is checked by evaluating the software in accordance with Annex R.*

NOTE 2 If the software program is modified, the evaluation and relevant tests are repeated if the modification can influence the results of the test involving **protective electronic circuits**.

22.47 Appliances intended to be connected to the water mains shall withstand the water pressure expected in normal use.

*Compliance is checked by connecting the appliance to a water supply having a static pressure equal to twice the maximum inlet water pressure or 1,2 MPa, whichever is higher, for a period of 5 min.*

*There shall be no leakage from any part, including any inlet water hose.*

22.48 Appliances intended to be connected to the water mains shall be constructed to prevent backsiphonage of non-potable water into the water mains.

*Compliance is checked by the relevant tests of IEC 61770. **A1***

**A2** 22.49 For **remote operation**, the duration of operation shall be set before the appliance can be started unless the appliance switches off automatically at the end of a cycle or it can operate continuously without giving rise to a hazard.

*Compliance is checked by inspection.*

NOTE For appliances such as ovens, the duration of operation has to be set before the appliance can be started. Washing machines and dishwashers are examples of appliances that switch off automatically at the end of a cycle. Fans, storage water heaters, air conditioners and refrigerators are examples of appliances that can operate continuously without giving rise to a hazard.

22.50 Controls incorporated in the appliance, if any, shall take priority over controls actuated by **remote operation**.

*Compliance is checked by inspection and by appropriate tests if necessary.*

22.51 A control on the appliance shall be manually adjusted to the setting for **remote operation** before the appliance can be operated in this mode. There shall be a visual indication on the appliance showing that the appliance is adjusted for **remote operation**. The manual setting and the visual indication of the remote mode are not necessary on appliances that can

- operate continuously, or
- operate automatically, or
- be operated remotely,

without giving rise to a hazard. **A2**



**A2** *Compliance is checked by inspection.*

NOTE Examples of appliances that can operate continuously, automatically or remotely without giving rise to a hazard are fans, storage water heaters, air conditioners, refrigerators and drives for awnings, windows, doors, gates and rolling shutters.

**22.52** Socket-outlets on appliances accessible to the user shall be in accordance with the socket-outlet system used in the country in which the appliance is sold.

*Compliance is checked by inspection.* **A2**

## 23 Internal wiring

**23.1** Wireways shall be smooth and free from sharp edges.

Wires shall be protected so that they do not come into contact with burrs, cooling fins or similar edges which may cause damage to their insulation.

Holes in metal through which insulated wires pass shall have smooth well-rounded surfaces or be provided with bushings.

Wiring shall be effectively prevented from coming into contact with moving parts.

*Compliance is checked by inspection.*

**23.2** Beads and similar ceramic insulators on live wires shall be fixed or located so that they cannot change their position or rest on sharp edges. If beads are inside flexible metal conduits, they shall be contained within an insulating sleeve, unless the conduit cannot move in normal use.

*Compliance is checked by inspection and by manual test.*

**23.3** Different parts of an appliance that can move relative to each other in normal use or during **user maintenance** shall not cause undue stress to electrical connections and internal conductors, including those providing earthing continuity. Flexible metallic tubes shall not cause damage to the insulation of the conductors contained within them. Open-coil springs shall not be used to protect the wiring. If a coiled spring, the turns of which touch one another, is used for this purpose, there shall be an adequate insulating lining in addition to the insulation of the conductors.

NOTE 1 The sheath of a flexible cord complying with IEC 60227 or IEC 60245 is regarded as an adequate insulating lining.

*Compliance is checked by inspection and by the following test.*

*If flexing occurs in normal use, the appliance is placed in the normal position of use and is supplied at **rated voltage** and operated under **normal operation**.*

*The movable part is moved backwards and forwards, so that the conductor is flexed through the largest angle allowed by the construction, the rate of flexing being 30 per minute. The number of flexings is*

- 10 000, for conductors flexed during normal use;
- 100, for conductors flexed during **user maintenance**.

NOTE 2 A flexing is one movement, either backwards or forwards.

*The appliance shall not be damaged to the extent that compliance with this standard is impaired and it shall be fit for further use. In particular, the wiring and its connections shall withstand the electric strength test of 23.5, the test voltage being reduced to 1 000 V and applied between **live parts** and **accessible metal parts** only.*

**23.4** Bare internal wiring shall be rigid and fixed so that, in normal use, **clearances** or **creepage distances** cannot be reduced below the values specified in clause 29.

*Compliance is checked during the tests of 29.1 and 29.2.*

**23.5** The insulation of internal wiring shall withstand the electrical stress likely to occur in normal use.

*Compliance is checked as follows.*

*The **basic insulation** shall be electrically equivalent to the **basic insulation** of cords complying with IEC 60227 or IEC 60245 or comply with the following electric strength test.*

*A voltage of 2 000 V is applied for 15 min between the conductor and metal foil wrapped around the insulation. There shall be no breakdown.*

NOTE 1 If the **basic insulation** of the conductor does not fulfill one of these conditions, the conductor is considered to be bare.

NOTE 2 The test is only applied to wiring subjected to the supply voltage.

NOTE 3 For **class II construction**, the requirements for **supplementary insulation** and **reinforced insulation** apply except that the sheath of a cord complying with IEC 60227 or IEC 60245 may provide **supplementary insulation**.

**23.6** When sleeving is used as **supplementary insulation** on internal wiring, it shall be retained in position by positive means.

*Compliance is checked by inspection and by manual test.*

NOTE A sleeve is considered to be fixed by positive means if it can only be removed by breaking or cutting or if it is clamped at both ends.

**23.7** Conductors identified by the colour combination green/yellow shall only be used for earthing conductors.

*Compliance is checked by inspection.*

**23.8** Aluminium wires shall not be used for internal wiring.

NOTE Windings are not considered to be internal wiring.

*Compliance is checked by inspection.*

**23.9** Stranded conductors shall not be consolidated by lead-tin soldering where they are subjected to contact pressure, unless the clamping means is constructed so that there is no risk of bad contact due to cold flow of the solder.

NOTE 1 The requirement may be met by using spring terminals. Securing the clamping screws alone is not considered to be adequate.

NOTE 2 Soldering of the tip of a stranded conductor is allowed.

*Compliance is checked by inspection.*

**A1** **23.10** The insulation and sheath of internal wiring, incorporated in external hoses for the connection of an appliance to the water mains, shall be at least equivalent to that of light polyvinyl chloride sheathed flexible cord (code designation 60227 IEC 52).

*Compliance is checked by inspection.*

NOTE The mechanical characteristics specified in IEC 60227 are not evaluated. **A1**

## 24 Components

**24.1** Components shall comply with the safety requirements specified in the relevant IEC standards as far as they reasonably apply.

**A2** NOTE 1 Compliance with the IEC standard for the relevant component does not necessarily ensure compliance with the requirements of this standard.

NOTE 2 Motors are not required to comply with IEC 60034-1.

NOTE 3 Unless otherwise specified, the requirements of Clause 29 of this standard apply between **live parts** of components and **accessible parts** of the appliance.

NOTE 4 Unless otherwise specified, the requirements of 30.2 of this standard apply to parts of non-metallic material in components including parts of non-metallic material supporting current-carrying connections inside components.

Components that have been previously tested and shown to comply with the resistance to fire requirements in the IEC standard for the relevant component need not be retested provided that

- the severity specified in the component standard is not less than the severity specified in 30.2 of this standard and
- unless the preselection alternative is used, the test report for the component states whether it complied with the IEC standard for the relevant component with or without flame. Flames existing for a cumulative time not exceeding 2 s during the test are ignored.

If the above two conditions are not satisfied, the component is tested as part of the appliance.

There are two levels of severity specified for appliances for which 30.2.3 is applicable.

Components that have not been previously tested and shown to comply with the IEC standard for the relevant component are tested according to the requirements of 30.2 of this standard. **A2**

*Unless components have been previously tested and found to comply with the relevant IEC standard for the number of cycles specified, they are tested in accordance with 24.1.1 to*

**A2** 24.1.9. **A2**

*Components that have not been separately tested and found to comply with the relevant IEC standard, components that are not marked or not used in accordance with their marking, are tested in accordance with the conditions occurring in the appliance, the number of samples being that required by the relevant standard.*

**A2** NOTE 5 **A2** For automatic controls, marking includes documentation and declaration as specified in clause 7 of IEC 60730-1.

**A2** *Lampholders and starterholders that have not been previously tested and found to comply with the relevant IEC standard are tested as a part of the appliance and shall additionally comply with the gauging and interchangeability requirements of the relevant IEC standard under the conditions occurring in the appliance.*

NOTE 6 Where the relevant IEC standard specifies these gauging and interchangeability requirements at elevated temperatures, the temperatures measured during the tests of Clause 11 are used. **A2**

*When an IEC standard does not exist for a component, there are no additional tests specified.*

**24.1.1** *The relevant standard for capacitors likely to be permanently subjected to the supply voltage and used for radio interference suppression or for voltage dividing is IEC 60384-14. If they have to be tested, they are tested in accordance with annex F.*

NOTE Examples of capacitors likely to be permanently subjected to the supply voltage are capacitors incorporated in appliances

– for which 30.2.3 is applicable,

– for which 30.2.2 is applicable, unless the capacitor is disconnected from the supply mains by an on-off switch. This switch has to be double-pole if the capacitor is connected to earth.

**24.1.2** *The relevant standard for **safety isolating transformers** is IEC 61558-2-6. If they have to be tested, they are tested in accordance with annex G.*

**24.1.3** *The relevant standard for switches is IEC 61058-1. The number of cycles of operation declared for 7.1.4 of IEC 61058-1 shall be at least 10 000. If they have to be tested, they are tested in accordance with annex H.*

**A1** NOTE 1 **A1** The declared number of operating cycles is only applicable for switches required for compliance with this standard.

**A1** *If the switch operates a relay or contactor, the complete switching system is subjected to the test.*

NOTE 2 Motor starting relays complying with IEC 60730-2-10 are not retested. **A1**

**24.1.4** *The relevant standard for automatic controls is IEC 60730-1 together with its relevant part 2.*

The number of cycles of operation declared for 6.10 and 6.11 of IEC 60730-1 shall not be less than the following:

– <b>thermostats</b>	10 000
– <b>temperature limiters</b>	1 000
– <b>self-resetting thermal cut-outs</b>	300
▣ <sub>A1</sub> – <b>voltage-maintained non-self-resetting thermal cut-outs</b>	1 000
– <b>other non-self-resetting thermal cut-outs</b>	30 ▣ <sub>A1</sub>
– <b>timers</b>	3 000
– <b>energy regulators</b>	10 000

NOTE 1 The declared number of operating cycles are not applicable for automatic controls which operate during the test of clause 11, if the appliance meets the requirements of this standard when they are short-circuited.

If automatic controls have to be tested, they are also tested in accordance with subclauses 11.3.5 to 11.3.8 and clause 17 of IEC 60730-1 as type 1 controls.

NOTE 2 The tests of clauses 12, 13 and 14 of IEC 60730-1 are not carried out before carrying out the test of clause 17.

▣<sub>A1</sub> NOTE 3 The ambient temperature during the test of Clause 17 of IEC 60730-1 is that occurring during the test of Clause 11 in the appliance, as specified in footnote b of Table 3.

Thermal motor protectors are tested in combination with their motor under the conditions specified in Annex D.

For water valves containing **live parts** and that are incorporated in external hoses for connection of an appliance to the water mains, the degree of protection provided by enclosures against harmful ingress of water declared for subclause 6.5.2 of IEC 60730-2-8 shall be IPX7. ▣<sub>A1</sub>

**24.1.5** The relevant standard for appliance couplers is IEC 60320-1. However, for appliances classified higher than IPX0, the relevant standard is IEC 60320-2-3.

▣<sub>A1</sub> The relevant standard for interconnection couplers is IEC 60320-2-2. ▣<sub>A1</sub>

**24.1.6** The relevant standard for small lampholders similar to E10 lampholders is IEC 60238, the requirements for E10 lampholders being applicable. However, they need not accept a lamp with an E10 cap complying with the current edition of Standard Sheet 7004-22 of IEC 60061-1.

▣<sub>A2</sub> **24.1.7** If the **remote operation** of the appliance is via a telecommunication network, the relevant standard for the telecommunication interface circuitry in the appliance is IEC 62151.

**24.1.8** The relevant standard for **thermal links** is IEC 60691. **Thermal links** that do not comply with IEC 60691 are considered to be an intentionally weak part for the purposes of Clause 19.

**24.1.9** Relays, other than motor starting relays, are tested as part of the appliance. However, they are also tested in accordance with Clause 17 of IEC 60730-1 under the maximum load conditions occurring in the appliance for at least the number of operations in 24.1.4 selected according to the relay function in the appliance. ▣<sub>A2</sub>

**24.2** Appliances shall not be fitted with

- switches or automatic controls in flexible cords;
- devices that cause the **protective device** in the fixed wiring to operate in the event of a fault in the appliance;
- **thermal cut-outs** that can be reset by a soldering operation.

NOTE The use of solder having a melting point at least 230 °C is allowed.

*Compliance is checked by inspection.*

**24.3** Switches intended to ensure **all-pole disconnection** of **stationary appliances**, as required in 22.2, shall be directly connected to the supply terminals and shall have a contact separation in all poles, providing full disconnection under overvoltage category III conditions.

NOTE 1 Full disconnection is contact separation of a pole to ensure the equivalent of **basic insulation**, in accordance with IEC 61058-1, between the supply mains and those parts that are intended to be disconnected.

NOTE 2 **Rated impulse voltages** for overvoltage categories are given in table 15.

*Compliance is checked by inspection and by measurement.*

**24.4** Plugs and socket-outlets for **extra-low voltage** circuits, and those used as terminal devices for heating elements, shall not be interchangeable with plugs and socket-outlets listed in IEC 60083 or IEC 60906-1 or with connectors and appliance inlets complying with the standard sheets of IEC 60320-1.

*Compliance is checked by inspection.*

**24.5** Capacitors in auxiliary windings of motors shall be marked with their rated voltage and their rated capacitance and shall be used in accordance with these markings.

☐<sub>11</sub> Text deleted ☐<sub>11</sub>

*Compliance is checked by inspection and by the appropriate tests. In addition, for capacitors connected in series with a motor winding, it is verified that, when the appliance is supplied at 1,1 times **rated voltage** and under minimum load, the voltage across the capacitor does not exceed 1,1 times its rated voltage.*

**24.6** The **working voltage** of motors directly connected to the supply mains and having **basic insulation** that is inadequate for the **rated voltage** of the appliance, shall not exceed 42 V. In addition, they shall comply with the requirements of annex I.

*Compliance is checked by measurement and by the tests of annex I.*

**A<sub>1</sub>** **24.7** Hose-sets for the connection of appliances to the water mains shall comply with IEC 61770. They shall be supplied with the appliance.

*Compliance is checked by inspection.* ☐<sub>A1</sub>

**25 Supply connection and external flexible cords**

**25.1** Appliances, other than those intended to be permanently connected to fixed wiring, shall be provided with one of the following means for connection to the supply mains:

- **supply cord** fitted with a plug;

- an appliance inlet having at least the same degree of protection against moisture as required for the appliance;
- pins for insertion into socket-outlets.

*Compliance is checked by inspection.*

**25.2** Appliances, other than **stationary appliances** for multiple supply, shall not be provided with more than one means of connection to the supply mains. **Stationary appliances** for multiple supply may be provided with more than one means of connection provided that the relevant circuits are adequately insulated from each other.

NOTE 1 For example, a multiple supply may be required for appliances supplied with day and night tariffs.

*Compliance is checked by inspection and by the following test.*

*A voltage of 1 250 V of substantially sinusoidal waveform and having a frequency of 50 Hz or 60 Hz is applied for 1 min between each means of connection to the supply mains.*

NOTE 2 This test may be combined with that of 16.3.

*During this test, no breakdown shall occur.*

**25.3** Appliances intended to be permanently connected to fixed wiring shall allow the connection of the supply conductors after the appliance has been fixed to its support and shall be provided with one of the following means for connection to the supply mains:

- a set of terminals allowing the connection of cables of fixed wiring having the nominal cross-sectional areas specified in 26.6;
- a set of terminals allowing the connection of a flexible cord;

NOTE 1 In this case it is allowed to connect the **supply cord** before the appliance is fixed to its support. The appliance may be provided with a flexible cord.

- a set of **supply leads** accommodated in a suitable compartment;
- a set of terminals and cable entries, conduit entries, knock-outs or glands, which allow the connection of the appropriate types of cable or conduit.

NOTE 2 If a **fixed appliance** is constructed so that parts can be removed to facilitate easy installation, the requirement is considered to be met if it is possible to connect the fixed wiring without difficulty after a part of the appliance has been fixed to its support. In this case, removable parts are to be constructed for ease of reassembly without risk of incorrect assembly or damage to the wiring or terminals.

*Compliance is checked by inspection and if necessary by making the appropriate connections.*

**25.4** For appliances intended to be permanently connected to the fixed wiring and having a **rated current** not exceeding 16 A, cable and conduit entries shall be suitable for cables or conduits having a maximum overall  $\text{A}_1$  dimension  $\text{A}_1$  shown in table 10.

**Table 10 –  $\text{A}_1$  Dimensions of cables and conduits**

Number of conductors including earthing conductors	Maximum overall dimension mm	
	Cable	Conduit <sup>a</sup>
2	13,0	16,0 (23,0)
3	14,0	16,0 (23,0)
4	14,5	20,0 (23,0)
5	15,5	20,0 (29,0)

<sup>a</sup> The dimensions in parentheses are for use in USA and Canada.

Conduit entries, cable entries and knock-outs shall be constructed or located so that the introduction of the conduit or cable does not reduce **clearances** or **creepage distances** below the values specified in clause 29.

*Compliance is checked by inspection and by measurement.*

**25.5 Supply cords** shall be assembled to the appliance by one of the following methods:

- **type X attachment**;
- **type Y attachment**;
- **type Z attachment**, if allowed in the relevant part 2.

**Type X attachments**, other than those having a specially prepared cord, shall not be used for flat twin tinsel cords.

*Compliance is checked by inspection.*

**25.6** Plugs shall not be fitted with more than one flexible cord.

*Compliance is checked by inspection.*

**☐** **Supply cords** of single-phase **portable appliances** having a **rated current** not exceeding 16 A shall be fitted with a plug complying with the following standard sheets of IEC 60083:1975:

- for **class I appliances**                      standard sheet C2b, C3b or C4;
- for **class II appliances**                      standard sheet C5 or C6. **☐**

**A<sub>2</sub>** **25.7 Supply cords** shall be one of the following types:

- Rubber sheathed.

Their properties shall be at least those of ordinary tough rubber sheathed cords (code designation 60245 IEC 53);

NOTE 1 These cords are not suitable for appliances intended to be used outdoors or when they are liable to be exposed to significant amounts of ultraviolet radiation.

- Polychloroprene sheathed.

Their properties shall be at least those of ordinary polychloroprene sheathed cords (code designation 60245 IEC 57);

NOTE 2 These cords are suitable for appliances intended to be used in low temperature applications.

- Cross-linked polyvinyl chloride sheathed.

Their properties shall be at least those of cross-linked polyvinyl chloride sheathed cords (code designation 60245 IEC 87);

NOTE 3 These cords are suitable for appliances when they may come into contact with hot surfaces. Due to the composition of the conductors, the cords are suitable for applications where high flexibility is required. **A<sub>2</sub>**



- $\square_{A2}$  Polyvinyl chloride sheathed.

These cords shall not be used if they are likely to touch metal parts having a temperature rise exceeding 75 K during the test of Clause 11. Their properties shall be at least those of

- light polyvinyl chloride sheathed cord (code designation 60227 IEC 52) for appliances having a mass not exceeding 3 kg;
- ordinary polyvinyl chloride sheathed cord (code designation 60227 IEC 53), for other appliances;

- Heat resistant polyvinyl chloride sheathed.

These cords shall not be used for **type X attachment** other than specially prepared cords. Their properties shall be at least those of

- heat-resistant light polyvinyl chloride sheathed cord (code designation 60227 IEC 56), for appliances having a mass not exceeding 3 kg;
- heat-resistant polyvinyl chloride sheathed cord (code designation 60227 IEC 57), for other appliances.

*Compliance is checked by measurement.*  $\square_{A2}$

**25.8** Conductors of **supply cords** shall have a nominal cross-sectional area not less than that shown in table 11.

**Table 11 – Minimum cross-sectional area of conductors**

Rated current of appliance A	Nominal cross-sectional area mm <sup>2</sup>
≤0,2	Tinsel cord <sup>a</sup>
>0,2 and ≤3	0,5 <sup>a</sup>
>3 and ≤6	0,75
$\square_{A1}$ >6 and ≤10	1,0 (0,75) <sup>b</sup>
>10 and ≤16	1,5 (1,0) <sup>b</sup> $\square_{A1}$
>16 and ≤25	2,5
>25 and ≤32	4
>32 and ≤40	6
>40 and ≤63	10

<sup>a</sup> These cords may only be used if their length does not exceed 2 m between the point where the cord or cord guard enters the appliance and the entry to the plug.

<sup>b</sup> Cords having the cross-sectional areas indicated in the parentheses may be used for **portable appliances** if their length does not exceed 2 m.

*Compliance is checked by measurement.*

**25.9** **Supply cords** shall not be in contact with sharp points or edges of the appliance.

*Compliance is checked by inspection.*

**25.10** The **supply cord** of **class I appliances** shall have a green/yellow core that is connected to the earthing terminal of the appliance and to the earthing contact of the plug.

*Compliance is checked by inspection.*

**25.11** Conductors of **supply cords** shall not be consolidated by lead-tin soldering where they are subjected to contact pressure, unless the clamping means is constructed so that there is no risk of a bad contact due to cold flow of the solder.

NOTE 1 The requirement may be met by using spring terminals. Securing the clamping screws alone is not considered to be adequate.

NOTE 2 Soldering of the tip of a stranded conductor is allowed.

*Compliance is checked by inspection.*

**25.12** The insulation of the **supply cords** shall not be damaged when moulding the cord to part of the enclosure.

*Compliance is checked by inspection.*

**25.13** Inlet openings for **supply cords** shall be constructed so that the sheath of the **supply cord** can be introduced without risk of damage. Unless the enclosure at the inlet opening is insulating material, a **non-detachable lining** or **non-detachable bushing** shall be provided that complies with 29.3 for **supplementary insulation**. If the **supply cord** is unsheathed, a similar additional bushing or lining is required, unless the appliance is **class 0**.

*Compliance is checked by inspection*

**25.14** Appliances provided with a **supply cord** that are moved while in operation shall be constructed so that the **supply cord** is adequately protected against excessive flexing where it enters the appliance.

NOTE 1 This does not apply to appliances with automatic cord reels that are tested by 22.16 instead.

*Compliance is checked by the following test that is carried out on an apparatus having an oscillating member as shown in figure 8.*

*The part of the appliance that includes the inlet opening is fixed to the oscillating member so that, when the **supply cord** is at the middle of its travel, the axis of the cord where it enters the cord guard or inlet is vertical and passes through the axis of oscillation. The major axis of the section of flat cords shall be parallel to the axis of oscillation.*

*The cord is loaded so that the force applied is*

- 10 N, for cords having a nominal cross-sectional area exceeding 0,75 mm<sup>2</sup>;
- 5 N, for other cords.

*The distance X, as shown in figure 8, between the axis of oscillation and the point where the cord or cord guard enters the appliance, is adjusted so that when the oscillating member moves over its full range, the cord and load make the minimum lateral movement.*

The oscillating member is moved through an angle of 90° (45° on either side of the vertical), the number of flexings for **type Z attachments** being 20 000 and for other attachments 10 000. The rate of flexing is 60 per minute.

NOTE 2 A flexing is one movement of 90°.

The cord and its associated parts are turned through an angle of 90° after half the number of flexings, unless a flat cord is fitted.

During the test, the conductors are supplied at **rated voltage** and loaded with the **rated current** of the appliance.

NOTE 3 Current is not passed through the earthing conductor.

The test shall not result in

- a short circuit between the conductors;
- a breakage of more than 10 % of the strands of any conductor;
- separation of the conductor from its terminal;
- loosening of any cord guard;
- damage to the cord or cord guard which could impair compliance with this standard;
- broken strands piercing the insulation and becoming accessible.

NOTE 4 Conductors include earthing conductors.

NOTE 5 A short circuit between conductors of the cord is considered to occur if the current exceeds a value equal to twice the **rated current** of the appliance.

**25.15** Appliances provided with a **supply cord**, and appliances intended to be permanently connected to fixed wiring by a flexible cord, shall have a cord anchorage. The cord anchorage shall relieve conductors from strain, including twisting, at the terminals and protect the insulation of the conductors from abrasion.

It shall not be possible to push the cord into the appliance to such an extent that the cord or internal parts of the appliance could be damaged.

Compliance is checked by inspection, by manual test and by the following test.

A mark is made on the cord while it is subjected to the pull force shown in table 12, at a distance of approximately 20 mm from the cord anchorage or other suitable point.

The cord is then pulled, without jerking, for 1 s in the most unfavourable direction with the force specified. The test is carried out 25 times.

The cord, unless on an automatic cord reel, is then subjected to a torque that is applied as close as possible to the appliance. The torque is specified in table 12 and is applied for 1 min.

**Table 12 – Pull force and torque**

<b>Mass of appliance</b> kg	<b>Pull force</b> N	<b>Torque</b> Nm
≤1	30	0,1
>1 and ≤4	60	0,25
>4	100	0,35

*During the tests, the cord shall not be damaged and shall show no appreciable strain at the terminals. The pull force is reapplied and the cord shall not be longitudinally displaced by more than 2 mm.*

**25.16** Cord anchorages for **type X attachments** shall be constructed and located so that

- replacement of the cord is easily possible;
- it is clear how the relief from strain and the prevention of twisting are obtained;
- they are suitable for the different types of **supply cord** that may be connected, unless the cord is specially prepared;
- the cord cannot touch the clamping screws of the cord anchorage if these screws are accessible, unless they are separated from **accessible metal parts** by **supplementary insulation**;
- the cord is not clamped by a metal screw which bears directly on the cord;
- at least one part of the cord anchorage is securely fixed to the appliance, unless it is part of a specially prepared cord;
- screws which have to be operated when replacing the cord do not fix any other component. However, this does not apply if
  - after removal of the screws, or if the component is incorrectly repositioned, the appliance becomes inoperative or is obviously incomplete;
  - the parts intended to be fastened by them cannot be removed without the aid of a **tool** during the replacement of the cord;
- if labyrinths can be bypassed the test of 25.15 is nevertheless withstood;
- for **class 0 appliances**, **class 0I appliances** and **class I appliances**, they are of insulating material or are provided with an insulating lining, unless failure of the insulation of the cord does not make **accessible metal parts** live;
- for **class II appliances**, they are of insulating material or, if of metal, they are insulated from **accessible metal parts** by **supplementary insulation**.

NOTE 1 If the cord anchorage for **type X attachment** comprises one or more clamping members to which pressure is applied by means of nuts engaging with studs that are securely attached to the appliance, the cord anchorage is considered to have one part securely fixed to the appliance, even if the clamping member can be removed from the studs.

NOTE 2 If the pressure on the clamping members is applied by means of one or more screws engaging with separate nuts or with a thread in a part that is integral with the appliance, the cord anchorage is not considered to have one part securely fixed to the appliance. This does not apply if one of the clamping members is fixed to the appliance or the surface of the appliance is of insulating material and shaped so that it is obvious that this surface is one of the clamping members.

NOTE 3 Examples of acceptable and unacceptable constructions of cord anchorages are shown in figure 9.

*Compliance is checked by inspection and by the test of 25.15 under the following conditions.*

*The tests are carried out with the lightest permissible type of cord of the smallest cross-sectional area specified in table 13 and then with the next heavier type cord having the largest cross-sectional area specified. However, if the appliance is fitted with a specially prepared cord, the test is carried out with this cord.*

*The conductors are placed in the terminals and any terminal screws tightened just sufficiently to prevent the conductors from easily changing their position. The clamping screws of the cord anchorage are tightened with two-thirds of the torque specified in 28.1.*

*Screws of insulating material bearing directly on the cord are fastened with two-thirds of the torque specified in column I of table 14, the length of the slot in the screw head being taken as the nominal diameter of the screw.*

*After the test, the conductors shall not have moved by more than 1 mm in the terminals.*

**25.17** For **type Y attachment** and **type Z attachment**, cord anchorages shall be adequate.

*Compliance is checked by the test of 25.15.*

NOTE The test is carried out on the cord supplied with the appliance.

**25.18** Cord anchorages shall be arranged so that they are only accessible with the aid of a **tool** or shall be constructed so that the cord can only be fitted with the aid of a **tool**.

*Compliance is checked by inspection.*

**25.19** For **type X attachment**, glands shall not be used as cord anchorages in **portable appliances**. Tying the cord into a knot or tying the cord with string is not allowed.

*Compliance is checked by inspection.*

**25.20** The insulated conductors of the **supply cord** for **type Y attachment** and **type Z attachment** shall be additionally insulated from **accessible metal parts** by **basic insulation** for **class 0 appliances**, **class 0I appliances** and **class I appliances**, and by **supplementary insulation** for **class II appliances**. This insulation may be provided by the sheath of the **supply cord** or by other means.

*Compliance is checked by inspection and by the relevant tests.*

**25.21** The space for the connection of **supply cords** having **type X attachment**, or for the connection of fixed wiring, shall be constructed

- so that it is possible to check that the supply conductors are correctly positioned and connected before fitting any cover;
- so that any cover can be fitted without risk of damage to the conductors or their insulation;
- for **portable appliances**, so that the uninsulated end of a conductor, should it become free from the terminal, cannot come into contact with **accessible metal parts**.

*Compliance is checked by inspection after fitting cables or flexible cords having the largest cross-sectional area specified in table 13.*

**Portable appliances** are subjected to the following additional test unless they are provided with pillar terminals and the **supply cord** is clamped within 30 mm of them.

NOTE The **supply cord** may be clamped by a cord anchorage.

*The clamping screws or nuts are loosened in turn. A force of 2 N is applied to the conductor in any direction at a position adjacent to the terminal. The uninsulated end of the conductor shall not come into contact with **accessible metal parts**.*

## 25.22 Appliance inlets shall

- be located or enclosed so that **live parts** are not accessible during insertion or removal of the connector;
- be located so that the connector can be inserted without difficulty;
- be located so that, after insertion of the connector, the appliance is not supported by the connector when it is placed in any position of normal use on a flat surface;
- not be an appliance inlet for cold conditions if the temperature rise of external metal parts of the appliance exceeds 75 K during the test of clause 11, unless the **supply cord** is unlikely to touch such metal parts in normal use.

*Compliance is checked by inspection.*

NOTE Appliance inlets complying with IEC 60320-1 prevent access to **live parts** during insertion or removal of the connector.

## 25.23 Interconnection cords shall comply with the requirements for the **supply cord**, except that

- the cross-sectional area of the conductors of the **interconnection cord** is determined on the basis of the maximum current carried by the conductor during the test of clause 11 and not by the **rated current** of the appliance;
- the thickness of the insulation of the conductor may be reduced if the voltage of the conductor is less than the **rated voltage**.

*Compliance is checked by inspection, by measurement and if necessary by tests, such as the electric strength test of 16.3.*

## 25.24 Interconnection cords shall not be detachable without the aid of a **tool** if compliance with this standard is impaired when they are disconnected.

*Compliance is checked by inspection and if necessary by appropriate tests.*

**25.25** The dimensions of pins of appliances that are inserted into socket-outlets shall be compatible with the dimensions of the relevant socket-outlet. Dimensions of the pins and engagement face are to be in accordance with the dimensions of the relevant plug listed in IEC 60083.

*Compliance is checked by measurement.*

## 26 Terminals for external conductors

**26.1** Appliances shall be provided with terminals or equally effective devices for the connection of external conductors. The terminals shall only be accessible after the removal of a **non-detachable cover**.  $\text{A}_1$  However, earthing terminals may be accessible if a **tool** is required to make the connections and means are provided to clamp the wire independently from its connection.  $\text{A}_1$

NOTE 1 Screw type terminals in accordance with IEC 60998-2-1, screwless terminals in accordance with IEC 60998-2-2 and clamping units in accordance with IEC 60999-1 are considered to be effective devices.

NOTE 2 The terminals of a component such as a switch may be used as terminals for external conductors as long as they comply with the requirements of this clause.

*Compliance is checked by inspection and by manual test.*

**26.2** Appliances having **type X attachment**, except those having a specially prepared cord and appliances for connection to fixed wiring shall be provided with terminals in which the connections are made by means of screws, nuts or similar devices, unless the connections are soldered.

The screws and nuts shall not be used to fix any other component except that they may also clamp internal conductors if these are arranged so that they are unlikely to be displaced when fitting the supply conductors.

If soldered connections are used, the conductors shall be positioned or fixed so that reliance is not placed upon the soldering alone to maintain it in position. However, soldering alone may be used if barriers are provided so that **clearances** and **creepage distances** between **live parts** and other metal parts cannot be reduced below the values specified for **supplementary insulation** if the conductor becomes free at the soldered joint.

**A2** NOTE Conductors connected by soldering are not considered to be positioned or fixed so that reliance is not placed upon the soldering alone to maintain it in position unless they are held in place near the terminals independently of the solder. **A2**

*Compliance is checked by inspection and by measurement.*

**26.3** Terminals for **type X attachment** and those for connection to fixed wiring shall be constructed so that they clamp the conductor between metal surfaces with sufficient contact pressure but without causing damage to the conductor.

The terminals shall be fixed so that when the clamping means is tightened or loosened

- the terminal does not become loose;
- internal wiring is not subjected to stress;
- **clearances** and **creepage distances** are not reduced below the values specified in clause 29.

NOTE 1 Terminals may be prevented from loosening by fixing with two screws, by fixing with one screw in a recess so that there is no appreciable movement, or by other suitable means. The use of sealing compound without other means of locking is not considered to be sufficient. However, self-hardening resins may be used to lock terminals that are not subject to torsion in normal use.

*Compliance is checked by inspection and by the test of subclause **A2** 9.6 **A2** of IEC 60999-1, the torque applied being equal to two-thirds of the torque specified.*

NOTE 2 Conductors are considered to be damaged if they show deep or sharp indentations.

**26.4** Terminals for **type X attachment**, except **type X attachments** having a specially prepared cord, and terminals for connection to fixed wiring, shall not require special preparation of the conductor. They shall be constructed or placed so that the conductor cannot slip out when clamping screws or nuts are tightened.

*Compliance is checked by inspection of the terminals and conductors after the test of 26.3.*

NOTE Soldering of the strands of the conductor, the use of cable lugs, eyelets or similar devices, is not considered to meet the requirement, but reshaping of the conductor before its introduction into the terminal or twisting a stranded conductor to consolidate the end is allowed.

**26.5** Terminals for **type X attachment** shall be located or shielded so that if a wire of a stranded conductor escapes when the conductors are fitted, there is no risk of accidental connection to other parts that could result in a hazard.

*Compliance is checked by inspection and by the following test.*

*A 8 mm length of insulation is removed from the end of a flexible conductor having a nominal cross-sectional area as specified in table 11. One wire of the stranded conductor is left free and the other wires are fully inserted and clamped in the terminal. The free wire is bent, without tearing the insulation back, in every possible direction but without making sharp bends around barriers.*

NOTE The test is also applied to earthing conductors.

*There shall be no contact between **live parts** and **accessible metal parts** and, for **class II constructions**, between **live parts** and metal parts separated from **accessible metal parts** by **supplementary insulation** only.*

**26.6** Terminals for **type X attachment** and for connection to fixed wiring shall allow the connection of conductors having the nominal cross-sectional areas shown in table 13. However, if a specially prepared cord is used, the terminals need only be suitable for the connection of that cord.

**Table 13 – Nominal cross-sectional area of conductors**

Rated current of appliance A	Nominal cross-sectional area mm <sup>2</sup>	
	Flexible cords	Cable for fixed wiring
≤3	0,5 and 0,75	1 to 2,5
>3 and ≤6	0,75 and 1	1 to 2,5
>6 and ≤10	1 and 1,5	1 to 2,5
>10 and ≤16	1,5 and 2,5	1,5 to 4
>16 and ≤25	2,5 and 4	2,5 to 6
>25 and ≤32	4 and 6	4 to 10
$\square_{A2}$ >32 and ≤50	6 and 10	6 to 16
>50 and ≤63	10 and 16	10 to 25 $\square_{A2}$

*Compliance is checked by inspection, by measurement and by fitting cables or cords of the smallest and largest cross-sectional areas specified.*

**26.7** Terminals for **type X attachment** shall be accessible after removal of a cover or part of the enclosure.

*Compliance is checked by inspection.*

**26.8** Terminals for the connection of fixed wiring, including the earthing terminal, shall be located close to each other.

*Compliance is checked by inspection.*



**26.9** Terminals of the pillar type shall be constructed and located so that the end of a conductor introduced into the hole is visible, or can pass beyond the threaded hole for a distance equal to half the nominal diameter of the screw but at least 2,5 mm.

*Compliance is checked by inspection and by measurement.*

**26.10** Terminals with screw clamping and screwless terminals shall not be used for the connection of the conductors of flat twin tinsel cords unless the ends of the conductors are fitted with means suitable for use with screw terminals.

*Compliance is checked by inspection and by applying a pull of 5 N to the connection.*

*After the test, the connections shall show no damage that could impair compliance with this standard.*

**26.11** For appliances having **type Y attachment** or **type Z attachment**, soldered, welded, crimped or similar connections may be used for the connection of external conductors. For **class II appliances**, the conductor shall be positioned or fixed so that reliance is not placed upon the soldering, crimping or welding alone to maintain the conductor in position. However, these methods may be used alone if barriers are provided so that **clearances** and **creepage distances** between **live parts** and other metal parts cannot be reduced below the values specified for **supplementary insulation**, if the conductor becomes free at the soldered or welded joint or slips out of the crimped connection.

**A2** NOTE Conductors connected by soldering are not considered to be positioned or fixed so that reliance is not placed upon the soldering alone to maintain it in position unless they are held in place near the terminals independently of the solder. **A2**

*Compliance is checked by inspection and by measurement.*

## 27 Provision for earthing

**27.1 Accessible metal parts** of **class 0I appliances** and **class I appliances** that may become live in the event of an insulation fault, shall be permanently and reliably connected to an earthing terminal within the appliance or to the earthing contact of the appliance inlet.

Earthing terminals and earthing contacts shall not be connected to the neutral terminal.

**Class 0 appliances**, **class II appliances** and **class III appliances** shall have no provision for earthing.

**Safety extra-low voltage** circuits shall not be earthed unless they are **protective extra-low voltage circuits**.

*Compliance is checked by inspection.*

NOTE 1 If **accessible metal parts** are screened from **live parts** by metal parts that are connected to the earthing terminal or to the earthing contact, they are not regarded as likely to become live in the event of an insulation fault.

NOTE 2 Metal parts behind a decorative cover that does not withstand the test of **A1** 21.1 **A1** are considered to be **accessible metal parts**.

**27.2** The clamping means of earthing terminals shall be adequately secured against accidental loosening.

NOTE 1 In general, the constructions commonly used for current-carrying terminals, other than some terminals of the pillar type, provide sufficient resiliency to comply with this requirement. For other constructions, special provisions, such as the use of an adequately resilient part that is not likely to be removed inadvertently, may be necessary.

Terminals for the connection of external equipotential bonding conductors shall allow the connection of conductors having nominal cross-sectional areas of 2,5 mm<sup>2</sup> to 6 mm<sup>2</sup> and shall not be used to provide earthing continuity between different parts of the appliance. It shall not be possible to loosen the conductors without the aid of a tool.

NOTE 2 The earthing conductor in a supply cord is not considered to be an equipotential bonding conductor.

*Compliance is checked by inspection and by manual test.*

**27.3** <sup>A1</sup> If a detachable part having an earth connection is plugged into another part of the appliance, the earth connection shall be made before the current-carrying connections are established. The current-carrying connections shall be separated before the earth connection when removing the part. <sup>A1</sup>

For appliances with supply cords, the arrangement of the terminals, or the length of the conductors between the cord anchorage and the terminals, shall be such that the current-carrying conductors become taut before the earthing conductor if the cord slips out of the cord anchorage.

*Compliance is checked by inspection and by manual test.*

**27.4** All parts of the earthing terminal intended for the connection of external conductors shall be such that there is no risk of corrosion resulting from contact between these parts and the copper of the earthing conductor or any other metal in contact with these parts.

Parts providing earthing continuity, other than parts of a metal frame or enclosure, shall be of metal having adequate resistance to corrosion. If these parts are of steel, they shall be provided at the essential areas with an electroplated coating having a thickness of at least 5 µm.

NOTE 1 Parts of copper or copper alloys containing at least 58 % copper for parts that are worked cold, and at least 50 % copper for other parts, and parts of stainless steel containing at least 13 % chrome are considered to be sufficiently resistant to corrosion.

NOTE 2 The essential areas of steel parts are, in particular, those liable to transmit a fault current. In evaluating such areas, the thickness of the coating in relation to the shape of the part has to be taken into account. In case of doubt, the thickness of the coating is measured as described in ISO 2178 or in ISO 1463.

Parts of coated or uncoated steel that are only intended to provide or to transmit contact pressure shall be adequately protected against rusting.

NOTE 3 Examples of parts providing earthing continuity and parts that are only intended to provide or to transmit contact pressure are shown in figure 10.

NOTE 4 Parts subjected to a treatment such as chromate conversion coating are in general not considered to be adequately protected against corrosion, but they may be used to provide or to transmit contact pressure.

If the body of the earthing terminal is a part of a frame or enclosure of aluminium or aluminium alloy, precautions shall be taken to avoid the risk of corrosion resulting from contact between copper and aluminium or its alloys.

*Compliance is checked by inspection and by measurement.*

**27.5** The connection between the earthing terminal or earthing contact and earthed metal parts shall have low resistance.

If the **clearances** of **basic insulation** in a **protective extra-low voltage circuit** are based on the **rated voltage** of the appliance, this requirement does not apply to connections providing earthing continuity in the **protective extra-low voltage circuit**.

*Compliance is checked by the following test.*

*A current derived from a source having a nominal voltage not exceeding 12 V (a.c. or d.c.) and equal to 1,5 times **rated current** of the appliance or 25 A, whichever is higher, is passed between the earthing terminal or earthing contact and each of the **accessible metal parts** in turn.*

*The voltage drop between the earthing terminal of the appliance or the earthing contact of the appliance inlet and the **accessible metal part** is measured. The resistance calculated from the current and this voltage drop shall not exceed 0,1  $\Omega$ .*

NOTE 1 In case of doubt, the test is carried out until steady conditions have been established.

NOTE 2 The resistance of the **supply cord** is not included in the measurement.

NOTE 3 Care is to be taken to ensure that the contact resistance between the tip of the measuring probe and the metal part under test does not influence the test results.

**A2) 27.6** The printed conductors of printed circuit boards shall not be used to provide earthing continuity in **hand-held appliances**. They may be used to provide earthing continuity in other appliances if at least two tracks are used with independent soldering points and the appliance complies with 27.5 for each circuit.

*Compliance is checked by inspection and by the relevant tests. **A2)***

## **28 Screws and connections**

**28.1** Fixings, the failure of which may impair compliance with this standard, electrical connections and connections providing earthing continuity shall withstand the mechanical stresses occurring in normal use.

Screws used for these purposes shall not be of metal which is soft or liable to creep, such as zinc or aluminium. If they are of insulating material, they shall have a nominal diameter of at least 3 mm and they shall not be used for any electrical connections or connections providing earthing continuity.

Screws used for electrical connections or for connections providing earthing continuity shall screw into metal.

Screws shall not be of insulating material if their replacement by a metal screw could impair **supplementary insulation** or **reinforced insulation**. Screws that may be removed when replacing a **supply cord** having a **type X attachment** or when undertaking **user maintenance** shall not be of insulating material if their replacement by a metal screw could impair **basic insulation**.

*Compliance is checked by inspection and by the following test.*

Screws and nuts are tested if they are

- used for electrical connections;
- used for connections providing earthing continuity, unless at least two screws or nuts are used;
- likely to be tightened
  - during **user maintenance**;
  - when replacing a **supply cord** having a **type X attachment**;
  - during installation.

The screws or nuts are tightened and loosened without jerking:

- 10 times for screws in engagement with a thread of insulating material;
- 5 times for nuts and other screws.

Screws in engagement with a thread of insulating material are completely removed and reinserted each time.

When testing terminal screws and nuts, a cable or flexible cord of the largest cross-sectional area specified in table 13 is placed in the terminal. It is repositioned before each tightening.

The test is carried out by means of a suitable screwdriver, spanner or key and by applying a torque as shown in table 14.

Column I is applicable for metal screws without heads if the screw does not protrude from the hole when tightened.

Column II is applicable

- for other metal screws and for nuts;
- for screws of insulating material
  - having a hexagonal head with the dimension across flats exceeding the overall thread diameter;
  - with a cylindrical head and a socket for a key, the socket having a cross-corner dimension exceeding the overall thread diameter;
  - with a head having a slot or cross-slots, the length of which exceeds 1,5 times the overall thread diameter.

Column III is applicable for other screws of insulating material.

Table 14 – Torque for testing screws and nuts

Nominal diameter of screw (outer thread diameter) mm	Torque Nm		
	I	II	III
≤2,8	0,2	0,4	0,4
>2,8 and ≤3,0	0,25	0,5	0,5
>3,0 and ≤3,2	0,3	0,6	0,5
>3,2 and ≤3,6	0,4	0,8	0,6
>3,6 and ≤4,1	0,7	1,2	0,6
>4,1 and ≤4,7	0,8	1,8	0,9
<sup>A2</sup> >4,7 and ≤5,3	0,8	2,0	1,0 <sup>A2</sup>
>5,3	–	2,5	1,25

No damage impairing the further use of the fixings or connections shall occur.

**28.2** Electrical connections and connections providing earthing continuity shall be constructed so that contact pressure is not transmitted through insulating material that is liable to shrink or to distort unless there is sufficient resiliency in the metallic parts to compensate for any possible shrinkage or distortion of the insulating material.

NOTE Ceramic material is not liable to shrink or to distort.

This requirement does not apply to electrical connections in circuits carrying a current not exceeding 0,5 A.

Compliance is checked by inspection.

**28.3** Space-threaded (sheet metal) screws shall only be used for electrical connections if they clamp the parts together.

<sup>A2</sup> Thread-cutting (self-tapping) screws and thread rolling screws shall only be used for electrical connections if they generate a full form standard machine screw thread. However, thread-cutting (self-tapping) screws shall not be used if they are likely to be operated by the user or installer.

Thread-cutting, thread rolling and space-threaded screws may be used in connections providing earthing continuity provided it is not necessary to disturb the connection

- in normal use,
- during **user maintenance**,
- when replacing a **supply cord** having a **type X attachment**, or
- during installation.

At least two screws must be used for each connection providing earthing continuity unless the screw forms a thread having a length of at least half the diameter of the screw. <sup>A2</sup>

Compliance is checked by inspection.

**28.4** Screws and nuts that make a mechanical connection between different parts of the appliance shall be secured against loosening if they also make electrical connections or connections providing earthing continuity.

NOTE 1 This requirement does not apply to screws in the earthing circuit if at least two screws are used for the connection or if an alternative earthing circuit is provided.

NOTE 2 Spring washers, lock washers and crown type locks as part of the screw head are means that may provide satisfactory security.

NOTE 3 Sealing compound that softens on heating provides satisfactory security only for screw connections not subject to torsion in normal use.

Rivets used for electrical connections or for connections providing earthing continuity shall be secured against loosening if these connections are subject to torsion in normal use.

NOTE 4 This requirement does not imply that more than one rivet is necessary for providing earthing continuity.

NOTE 5 A non-circular shank or an appropriate notch may be sufficient.

*Compliance is checked by inspection and by manual test.*

## 29 Clearances, creepage distances and solid insulation

Appliances shall be constructed so that the **clearances**, **creepage distances** and solid insulation are adequate to withstand the electrical stresses to which the appliance is liable to be subjected.

*Compliance is checked by the requirements and tests of 29.1 to 29.3.*

**A2** If coatings are used on printed circuit boards to protect the microenvironment (Type 1 coating) or to provide **basic insulation** (Type 2 coating), Annex J applies. The microenvironment is pollution degree 1 under Type 1 coating. There are no **clearance** or **creepage distance** requirements under Type 2 coating. **A2**

NOTE 1 The requirements and tests are based on IEC 60664-1 from which further information can be obtained.

NOTE 2 The assessment of **clearances**, **creepage distances** and solid insulation has to be carried out separately.

**29.1** **A1** **Clearances** shall not be less than the values specified in Table 16, taking into account the **rated impulse voltage** for the overvoltage categories of Table 15, unless, for **basic insulation** and **functional insulation**, they comply with the impulse voltage test of Clause 14. However, if the construction is such that the distances could be affected by wear, by distortion, by movement of the parts or during assembly, the **clearances** for **rated impulse voltages** of 1 500 V and above are increased by 0,5 mm and the impulse voltage test is not applicable.

The impulse voltage test is not applicable when the microenvironment is pollution degree 3 or for **basic insulation of class 0 appliances** and **class 0I appliances**. **A1**

NOTE 1 Examples of constructions for which the test may be applicable are those having rigid parts or parts located by mouldings.

Examples of constructions in which distances are likely to be affected are those involving soldering, snap-on and screw terminals and **clearances** from motor windings.

Appliances are in overvoltage category II.

NOTE 2 If a circuit is specially protected by a device within the appliance, such as a surge **A2** protective **A2** device complying with IEC 61643-1, overvoltage category I may be applicable.

NOTE 3 Annex K gives information regarding overvoltage categories.

Table 15 – Rated impulse voltage

Rated voltage V	Rated impulse voltage V		
	Overvoltage category		
	I	II	III
≤50	330	500	800
>50 and ≤150	800	500	2 500
>150 and ≤300	1 500	2 500	4 000

NOTE 1 For multi-phase appliances, the line to neutral or line to earth voltage is used for **rated voltage**.

NOTE 2 The values are based on the assumption that the appliance will not generate higher overvoltages than those specified. If higher overvoltages are generated, the **clearances** have to be increased accordingly.

**A1** Text deleted **A1**

Table 16 – Minimum clearances

Rated impulse voltage V	Minimum clearance <sup>a</sup> mm
330	0,5 <sup>b, c</sup>
500	0,5 <sup>b, c</sup>
800	0,5 <sup>b, c</sup>
1 500	0,5 <sup>c</sup>
2 500	1,5
4 000	3,0
6 000	5,5
8 000	8,0
10 000	11,0

<sup>a</sup> The distances specified apply only to **clearances** in air.

<sup>b</sup> The smaller **clearances** specified in IEC 60664-1 have not been adopted for practical reasons, such as mass-production tolerances.

<sup>c</sup> This value is increased to 0,8 mm for pollution degree 3.

**A1**

Compliance is checked by inspection and by measurement.

Parts, such as hexagonal nuts that can be tightened to different positions during assembly, and movable parts, are placed in the most unfavourable position.

A force is applied to bare conductors, other than those of heating elements, and **accessible surfaces** to try to reduce **clearances** when making the measurement. The force is

- 2 N, for bare conductors,
- 30 N, for **accessible surfaces**.

The force is applied by means of test probe B of IEC 61032. Apertures are assumed to be covered by a piece of flat metal.

NOTE 4 The way in which **clearances** are measured is specified in IEC 60664-1.

NOTE 5 The procedure for assessing **clearances** is given in annex L.

$\text{A}_2$  NOTE 6 For appliances intended for use at altitudes exceeding 2 000 m, the altitude correction factors for clearances specified in Table A.2 of IEC 60664-1 should be taken into account.  $\text{A}_2$

**29.1.1** The **clearances** of **basic insulation** shall be sufficient to withstand the overvoltages likely to occur during use, taking into account the **rated impulse voltage**.  $\text{A}_2$  The values of Table 16, or the impulse voltage test of Clause 14, are applicable.  $\text{A}_2$

NOTE The overvoltages may be derived from external sources or due to switching.

The **clearance** at the terminals of tubular sheathed heating elements may be reduced to 1,0 mm if the microenvironment is pollution degree 1.

$\text{A}_1$  Lacquered conductors of windings are considered to be bare conductors.  $\text{A}_1$

*Compliance is checked by measurement.*

**29.1.2** **Clearances** of **supplementary insulation** shall be not less than those specified for **basic insulation** in table 16.

*Compliance is checked by measurement.*

**29.1.3** **Clearances** of **reinforced insulation** shall be not less than those specified for **basic insulation** in table 16, but using the next higher step for **rated impulse voltage** as a reference.

NOTE For **double insulation**, when there is no intermediate conductive part between the **basic insulation** and **supplementary insulation**, **clearances** are measured between **live parts** and the **accessible surface**, and the insulation system is treated as **reinforced insulation** as shown in figure 11.

*Compliance is checked by measurement.*

**29.1.4** For **functional insulation**, the values of table 16 are applicable. However, **clearances** are not specified if the appliance complies with clause 19 with the **functional insulation** short-circuited.  $\text{A}_1$  Lacquered conductors of windings are considered to be bare conductors. However, **clearances** at crossover points are not measured.  $\text{A}_1$

The **clearance** between surfaces of **PTC heating elements** may be reduced to 1 mm.

$\text{A}_1$  Text deleted  $\text{A}_1$

*Compliance is checked by measurement and by a test if necessary.*

**29.1.5** For appliances having higher **working voltages** than **rated voltage**, for example on the secondary side of a step-up transformer, or if there is a resonant voltage, the voltage used for determining **clearances** from table 16 shall be the sum of the **rated impulse voltage** and the difference between the peak value of the **working voltage** and the peak value of the **rated voltage**.

NOTE 1 **Clearances** for intermediate values of table 16 may be determined by interpolation.

NOTE 2 If the voltage for determining **clearance** is higher than 10 000 V, the case A values for **clearances** stated in table 2 of IEC 60664-1 are applicable.  $\text{A}_1$  Text deleted  $\text{A}_1$



If the secondary winding of a step-down transformer is earthed, or if there is an earthed screen between the primary and secondary windings, **clearances of basic insulation** on the secondary side shall be not less than those specified in table 16, but using the next lower step for **rated impulse voltage** as a reference.

NOTE 3 The use of an isolating transformer without an earthed protective screen or earthed secondary does not allow a reduction in the **rated impulse voltage**.

For circuits supplied with a voltage lower than **rated voltage**, for example on the secondary side of a transformer, **clearances of functional insulation** are based on the **working voltage**, which is used as the **rated voltage** in table 15.

*Compliance is checked by measurement.*

**29.2** Appliances shall be constructed so that **creepage distances** are not less than those appropriate for the **working voltage**, taking into account the material group and the pollution degree.

**A2** NOTE 1 The **working voltage** for parts connected to the neutral is the same as for parts connected to the phase and this is the **working voltage** for **basic insulation**. **A2**

Pollution degree 2 applies unless

- precautions have been taken to protect the insulation, in which case pollution degree 1 applies;
- the insulation is subjected to conductive pollution, in which case pollution degree 3 applies.

NOTE 2 An explanation of pollution degree is given in annex M.

*Compliance is checked by measurement.*

NOTE 3 The way in which **creepage distances** are measured is specified in IEC 60664-1.

*Parts such as hexagonal nuts that can be tightened to different positions during assembly, and movable parts, are placed in the most unfavourable position.*

*A force is applied to bare conductors, other than those of heating elements, and **accessible surfaces** to try to reduce **creepage distances** when making the measurement. The force is*

- 2 N, for bare conductors;
- 30 N, for **accessible surfaces**.

*The force is applied by means of test probe B of IEC 61032.*

*The relationship between the material group and the comparative tracking index (CTI) values, as given in subclause 2.7.1.3 of IEC 60664-1, is as follows:*

- material group I:  $600 \leq CTI$ ;
- material group II:  $400 \leq CTI < 600$ ;
- material group IIIa:  $175 \leq CTI < 400$ ;
- material group IIIb:  $100 \leq CTI < 175$ ,

*These CTI values are obtained in accordance with IEC 60112 using solution A. If the CTI value of the material is unknown, a proof tracking index (PTI) test in accordance with annex W is carried out at the CTI values specified, in order to establish the material group.*

NOTE 4 The test for comparative tracking index (CTI) in accordance with IEC 60112 is designed to compare the performance of various insulating materials under test conditions, namely drops of an aqueous contaminant falling on a horizontal surface leading to electrolytic conduction. It gives a qualitative comparison but in the case of insulating materials having a tendency to form tracks it can also give a quantitative comparison, namely the comparative tracking index.

NOTE 5 The procedure for assessing **creepage distances** is given in annex L.

**A2** NOTE 6 In a **double insulation** system, the **working voltage** for both the **basic insulation** and **supplementary insulation** is taken as the **working voltage** across the complete **double insulation** system. It is not divided according to thickness and dielectric constant of the **basic insulation** and **supplementary insulation**. **A2**

**29.2.1 Creepage distances** of **basic insulation** shall not be less than those specified in table 17.

Except for pollution degree 1, if the test of clause 14 has been used to check a particular **clearance**, the corresponding **creepage distance** shall not be less than the minimum dimension specified for the **clearance** of table 16.

Table 17 – Minimum creepage distances for basic insulation

Working voltage V			Creepage distance mm						
			Pollution degree						
			1	2			3		
				Material group			Material group		
I	II	IIIa/IIIb	I	II	IIIa/IIIb				
≤ 50	0,2	0,6	0,9	1,2	1,5	1,7	1,9 <sup>a</sup>		
>50 and ≤125	0,3	0,8	1,1	1,5	1,9	2,1	2,4		
>125 and ≤250	0,6	1,3	1,8	2,5	3,2	3,6	4,0		
>250 and ≤400	1,0	2,0	2,8	4,0	5,0	5,6	6,3		
>400 and ≤500	1,3	2,5	3,6	5,0	6,3	7,1	8,0		
>500 and ≤800	1,8	3,2	4,5	6,3	8,0	9,0	10,0		
>800 and ≤1 000	2,4	4,0	5,6	8,0	10,0	11,0	12,5		
>1 000 and ≤1 250	3,2	5,0	7,1	10,0	12,5	14,0	16,0		
>1 250 and ≤1 600	4,2	6,3	9,0	12,5	16,0	18,0	20,0		
>1 600 and ≤2 000	5,6	8,0	11,0	16,0	20,0	22,0	25,0		
>2 000 and ≤2 500	7,5	10,0	14,0	20,0	25,0	28,0	32,0		
>2 500 and ≤3 200	10,0	12,5	18,0	25,0	32,0	36,0	40,0		
>3 200 and ≤4 000	12,5	16,0	22,0	32,0	40,0	45,0	50,0		
>4 000 and ≤5 000	16,0	20,0	28,0	40,0	50,0	56,0	63,0		
>5 000 and ≤6 300	20,0	25,0	36,0	50,0	63,0	71,0	80,0		
>6 300 and ≤8 000	25,0	32,0	45,0	63,0	80,0	90,0	100,0		
>8 000 and ≤10 000	32,0	40,0	56,0	80,0	100,0	110,0	125,0		
>10 000 and ≤12 500	40,0	50,0	71,0	100,0	125,0	140,0	160,0		

NOTE 1 Lacquered conductors of windings are considered to be bare conductors, but **creepage distances** need not be greater than the associated **clearance** specified in table 16 taking into account 29.1.1.

NOTE 2 For glass, ceramics and other inorganic insulating materials that do not track, **creepage distances** need not be greater than the associated **clearance**.

NOTE 3 Except for circuits on the secondary side of an isolating transformer, the **working voltage** is considered to be not less than the **rated voltage** of the appliance.

<sup>a</sup> Material group IIIb is allowed if the **working voltage** does not exceed 50 V.

*Compliance is checked by measurement.*

**29.2.2 Creepage distances of supplementary insulation** shall be at least those specified for **basic insulation** in table 17.

NOTE Notes 1 and 2 of table 17 do not apply.

*Compliance is checked by measurement.*

**29.2.3 Creepage distances of reinforced insulation** shall be at least double those specified for **basic insulation** in table 17.

NOTE Notes 1 and 2 of table 17 do not apply.

*Compliance is checked by measurement.*

**29.2.4 Creepage distances of functional insulation** shall be not less than those specified in table 18. However, **creepage distances** may be reduced if the appliance complies with clause 19 with the **functional insulation** short-circuited.

**Table 18 – Minimum creepage distances for functional insulation**

Working voltage V	Creepage distance mm									
	Pollution degree 1				Pollution degree 3					
	Material group				Material group					
	I	II	IIIa/IIIb	I	II	IIIa/IIIb	I	II	IIIa/IIIb	
≤ 50	0,2	0,6	0,8	1,1	1,4	1,6	1,8 <sup>a</sup>			
>50 and ≤125	0,3	0,7	1,0	1,4	1,8	2,0	2,2			
>125 and ≤250	0,4	1,0	1,4	2,0	2,5	2,8	3,2			
>250 and ≤400 <sup>b</sup>	0,8	1,6	2,2	3,2	4,0	4,5	5,0			
>400 and ≤500	1,0	2,0	2,8	4,0	5,0	5,6	6,3			
>500 and ≤800	1,8	3,2	4,5	6,3	8,0	9,0	10,0			
>800 and ≤1 000	2,4	4,0	5,6	8,0	10,0	11,0	12,5			
>1 000 and ≤1 250	3,2	5,0	7,1	10,0	12,5	14,0	16,0			
>1 250 and ≤1 600	4,2	6,3	9,0	12,5	16,0	18,0	20,0			
>1 600 and ≤2 000	5,6	8,0	11,0	16,0	20,0	22,0	25,0			
>2 000 and ≤2 500	7,5	10,0	14,0	20,0	25,0	28,0	32,0			
>2 500 and ≤3 200	10,0	12,5	18,0	25,0	32,0	36,0	40,0			
>3 200 and ≤4 000	12,5	16,0	22,0	32,0	40,0	45,0	50,0			
>4 000 and ≤5 000	16,0	20,0	28,0	40,0	50,0	56,0	63,0			
>5 000 and ≤6 300	20,0	25,0	36,0	50,0	63,0	71,0	80,0			
>6 300 and ≤8 000	25,0	32,0	45,0	63,0	80,0	90,0	100,0			
>8 000 and ≤10 000	32,0	40,0	56,0	80,0	100,0	110,0	125,0			
>10 000 and ≤12 500	40,0	50,0	71,0	100,0	125,0	140,0	160,0			

NOTE 1 For **PTC heating elements**, the **creepage distances** over the surface of the PTC material need not be greater than the associated **clearance** for **working voltages** less than 250 V and for pollution degrees 1 and 2. However, the **creepage distances** between terminations are those specified in the table.

NOTE 2 For glass, ceramics and other inorganic insulating materials that do not track, **creepage distances** need not be greater than the associated **clearance**.

<sup>a</sup> Material group IIIb is allowed if the **working voltage** does not exceed 50 V.

<sup>b</sup> The **working voltage** between phases for appliances having a **rated voltage** in the range of 380 V to 415 V is > 250 V and ≤ 400 V.

*Compliance is checked by measurement.*

**29.3** <sup>A1</sup> **Supplementary insulation** and **reinforced insulation** shall have adequate thickness, or have a sufficient number of layers, to withstand the electrical stresses that can be expected during the use of the appliance.

Compliance is checked by

- measurement, in accordance with 29.3.1, or by
- an electric strength test in accordance with 29.3.2 if the insulation consists of more than one separate layer, other than natural mica or similar flakey material, or by <sup>A1</sup>
- <sup>C12</sup> an assessment of the thermal quality of the material combined with an electric strength test, in accordance with 29.3.3, and for accessible reinforced insulation consisting of a single layer, measurement in accordance with 29.3.Z1. <sup>C12</sup>

<sup>A1</sup> **29.3.1** The thickness of the insulation shall be at least

- 1 mm for **supplementary insulation**;
- 2 mm for **reinforced insulation**.

**29.3.2** Each layer of material shall withstand the electric strength test of 16.3 for **supplementary insulation**. **Supplementary insulation** shall consist of at least 2 layers of material and **reinforced insulation** of at least 3 layers.

**29.3.3** The insulation is subjected to the dry heat test Bb of IEC 60068-2-2 for 48 h at a temperature of 50 K in excess of the maximum temperature rise measured during the test of Clause 19. At the end of the period, the insulation is subjected to the electric strength test of 16.3 at the conditioning temperature and also after it has cooled down to room temperature.

If the temperature rise of the insulation measured during the tests of Clause 19 does not exceed the value specified in Table 3, the test of IEC 60068-2-2 is not carried out. <sup>A1</sup>

<sup>C12</sup> **29.3.Z1** If accessible **reinforced insulation** consists of a single layer, the thickness of this layer shall comply with Table Z.1.

**Table Z.1 – Minimum thickness for single layer accessible reinforced insulation**

Rated voltage V	Minimum thickness of single layers used for accessible reinforced insulation mm		
	Overvoltage category I	Overvoltage category II	Overvoltage category III
< 50	0,01	0,04	0,1
50 ≤ 150	0,1	0,3	0,6
150 ≤ 300	0,3	0,6	1,2

NOTE The creepage distance through a possible hole is not considered relevant because it is only stressed when the second electrode (human body) is present. <sup>C12</sup>

## 30 Resistance to heat and fire

**30.1** External parts of non-metallic material, parts of insulating material supporting **live parts** including connections, and parts of thermoplastic material providing **supplementary insulation** or **reinforced insulation**, shall be sufficiently resistant to heat if their deterioration could cause the appliance to fail to comply with this standard.

This requirement does not apply to the insulation or sheath of flexible cords or internal wiring.

Compliance is checked by subjecting the relevant part to the ball pressure test of IEC 60695-10-2.

The test is carried out at a temperature of  $40\text{ °C} \pm 2\text{ °C}$  plus the maximum temperature rise determined during the test of clause 11, but it shall be at least

- $75\text{ °C} \pm 2\text{ °C}$ , for external parts;
- $125\text{ °C} \pm 2\text{ °C}$ , for parts supporting **live parts**.

However, for parts of thermoplastic material providing **supplementary insulation** or **reinforced insulation**, the test is carried out at a temperature of  $25\text{ °C} \pm 2\text{ °C}$  plus the maximum temperature rise determined during the tests of clause 19, if this is higher. The temperature rises of 19.4 are taken into account provided that the test is terminated by the operation of a **non-self-resetting protective device** and it is necessary to remove a cover or use a **tool** to reset it.

NOTE 1 For coil formers, only those parts that support or retain terminals in position are subjected to the test.

NOTE 2 The test is not carried out on parts of ceramic material.

NOTE 3 The selection and sequence of tests for resistance to heat are shown in figure O.1.

**A2** 30.2 Parts of non-metallic material shall be resistant to ignition and spread of fire.

This requirement does not apply to decorative trims, knobs and other parts unlikely to be ignited or to propagate flames that originate inside the appliance.

Compliance is checked by the test of 30.2.1. In addition,

- for attended appliances, 30.2.2 is applicable;
- for unattended appliances, 30.2.3 is applicable.

Appliances for **remote operation** are considered to be appliances that are operated while unattended and consequently they are subjected to the test of 30.2.3.

For the base material of printed circuit boards, compliance is checked by the test of 30.2.4.

The tests are carried out on parts of non-metallic material that have been removed from the appliance. When the glow-wire test is carried out, the parts are placed in the same orientation as they would be in normal use.

NOTE 1 For parts that have been removed, it is the intention that IEC 60695-2-11 Clause 4 item c) applies, which states "remove the part under examination in its entirety and test it separately".

These tests are not carried out on the insulation of wires.

NOTE 2 The selection and sequence of tests for resistance to fire are shown in Figure O.2.

**30.2.1** Parts of non-metallic material are subjected to the glow-wire test of IEC 60695-2-11, which is carried out at  $550\text{ °C}$ .

The glow-wire test is not carried out on parts of material classified at least HB40 according to IEC 60695-11-10 provided that the test sample use for the classification was no thicker than the relevant part of the appliance. **A2**

**A<sub>2</sub>** Parts for which the glow-wire test cannot be carried out, such as those made of soft or foamy material, shall meet the requirements specified in ISO 9772 for material classified HBF, the test sample used for the classification being no thicker than the relevant part of the appliance.

**30.2.2** For appliances that are operated while attended, parts of non-metallic material supporting current-carrying connections, and parts of non-metallic material within a distance of 3 mm of such connections, are subjected to the glow-wire test of IEC 60695-2-11. However, the glow-wire test is not carried out on parts of material classified as having a glow-wire flammability index according to IEC 60695-2-12 of at least

- 750 °C, for connections which carry a current exceeding 0,5 A during **normal operation**,
- 650 °C, for other connections.

If the glow-wire flammability index is not available for a sample with a thickness within  $\pm 0,1$  mm of the relevant part, then the test sample shall have a thickness equal to the nearest preferred value specified in IEC 60695-2-12 that is no thicker than the relevant part.

NOTE 1 The preferred values in IEC 60695-2-12 are 0,75 mm  $\pm$  0,1 mm, 1,5 mm  $\pm$  0,1 mm and 3,0 mm  $\pm$  0,2 mm.

Where a non-metallic material is within 3 mm of a current carrying connection, but is shielded from the connection by a different material, the glow-wire test of IEC 60695-2-11 is carried out at the relevant temperature with the tip of the glow-wire applied to the interposed shielding material with the shielded material in place and not directly to the shielded material.

When the glow-wire test of IEC 60695-2-11 is carried out, the temperatures are

- 750 °C, for connections that carry a current exceeding 0,5 A during **normal operation**,
- 650 °C, for other connections.

NOTE 2 Contacts in components such as switch contacts are considered to be connections.

NOTE 3 The tip of the glow-wire should be applied to the part in the vicinity of the connection.

*This test is not applicable to:*

- parts supporting welded connections;
- parts supporting connections in low-power circuits described in 19.11.1;
- soldered connections on printed circuit boards;
- connections on small components on printed circuit boards;

*and parts within 3 mm of any of these connections.*

NOTE 4 Examples of small components are diodes, transistors, resistors, inductors, integrated circuits and capacitors not directly connected to the supply mains.

*It is also not applicable to*

- **hand-held appliances**;
- appliances that have to be kept switched on by hand or foot;
- appliances that are continuously loaded by hand. **A<sub>2</sub>**

**30.2.3** Appliances that are operated while unattended are tested as specified in 30.2.3.1 and 30.2.3.2. However, the tests are not applicable to

- parts supporting welded connections,
- parts supporting connections in low-power circuits described in 19.11.1
- soldered connections on printed circuit boards,
- connections on small components that are mounted on printed circuit boards and parts within 3 mm of any of these connections.

NOTE Examples of small components are diodes, transistors, resistors, inductors, integrated circuits and capacitors not directly connected to the supply mains.

**30.2.3.1** Parts of non-metallic material supporting connections that carry a current exceeding 0,2 A during **normal operation**, and parts of non-metallic material within a distance of 3 mm of such connections, are subjected to the glow-wire test of IEC 60695-2-11 with a test severity of 850 °C. However, the glow-wire test is not carried out on parts of material classified as having a glow-wire flammability index of at least 850 °C according to IEC 60695-2-12. If the glow-wire flammability index is not available for a sample with a thickness within  $\pm 0,1$  mm of the relevant part, then the test sample shall have a thickness equal to the nearest preferred value specified in IEC 60695-2-12 that is no thicker than the relevant part.

NOTE 1 The preferred values in IEC 60695-2-12 are 0,75 mm  $\pm$  0,1 mm, 1,5 mm  $\pm$  0,1 mm and 3,0 mm  $\pm$  0,2 mm.

NOTE 2 Contacts in components such as switch contacts are considered to be connections.

NOTE 3 The tip of the glow-wire is applied to the part in the vicinity of the connection.

The glow-wire test is also not carried out on small parts that comply with the needle-flame test of Annex E or on small parts of material classified as V-0 or V-1 according to IEC 60695-11-10 provided that the test sample used for the classification was no thicker than the relevant part of the appliance.

NOTE 4 Small parts are as defined in IEC 60695-4.

Where a non-metallic material is within 3 mm of a current carrying connection, but is shielded from the connection by a different material, the glow-wire test of IEC 60695-2-11 is carried out at the relevant temperature with the tip of the glow-wire applied to the interposed shielding material with the shielded material in place and not directly to the shielded material.

**30.2.3.2** Parts of non-metallic material supporting current-carrying connections, and parts of non-metallic material within a distance of 3 mm of such connections, are subjected to the glow-wire test of IEC 60695-2-11. However, the glow-wire test is not carried out on parts of material classified as having a glow-wire ignition temperature according to IEC 60695-2-13 of at least

- 775 °C, for connections that carry a current exceeding 0,2 A during **normal operation**,
- 675 °C, for other connections.

If the glow-wire ignition temperature is not available for a sample with a thickness within  $\pm 0,1$  mm of the relevant part, then the test sample shall have a thickness equal to the nearest preferred value specified in IEC 60695-2-13 that is no thicker than the relevant part.

NOTE 1 The preferred values in IEC 60695-2-13 are 0,75 mm  $\pm$  0,1 mm, 1,5 mm  $\pm$  0,1 mm and 3,0 mm  $\pm$  0,2 mm.

Where an non-metallic material is within 3 mm of a current carrying connection, but is shielded from the connection by a different material, the glow-wire test of IEC 60695-2-11 is carried out at the relevant temperature with the tip of the glow-wire applied to the interposed shielding material with the shielded material in place and not directly to the shielded material.  $\square$



**A2** When the glow-wire test of IEC 60695-2-11 is carried out, the temperatures are

- 750 °C, for connections that carry a current exceeding 0,2 A during **normal operation**
- 650 °C, for other connections.

NOTE 2 Contacts in components such as switch contacts are considered to be connections.

NOTE 3 The tip of the glow-wire is applied to the part in the vicinity of the connection.

If parts that withstand the glow-wire test of IEC 60695-2-11, but during the test produce a flame that persists for longer than 2 s, then these parts and adjacent parts are further tested as follows. Parts above the connection within the envelope of a vertical cylinder having a diameter of 20 mm and a height of 50 mm are subjected to the needle-flame test of Annex E. However, parts shielded by a flame barrier that meets the needle-flame test of Annex E are not tested.

The needle-flame test is not carried out on parts of material classified as V-0 or V-1 according to IEC 60695-11-10 provided that the test sample used for the classification was no thicker than the relevant part of the appliance.

**30.2.4** The base material of printed circuit boards is subjected to the needle-flame test of Annex E. The flame is applied to the edge of the board where the heat sink effect is lowest when the board is positioned as in normal use.

NOTE The test may be carried out on a printed circuit board on which components are mounted. However, ignition of a component is disregarded.

The test is not carried out:

- on printed circuit boards of low-power circuits described in 19.11.1;
- on the printed circuit boards in
  - a metal enclosure that confines flames or burning droplets,
  - **hand-held appliances**,
  - appliances that have to be kept switched on by hand or foot,
  - appliances that are continuously loaded by hand,
- on a base material classified as V-0 according to IEC 60695-11-10 provided that the test sample used for the classification was no thicker than the printed circuit board. **A2**

## 31 Resistance to rusting

Ferrous parts, the rusting of which might cause the appliance to fail to comply with this standard, shall be adequately protected against rusting.

NOTE Tests are specified in part 2 when necessary.

## 32 Radiation, toxicity and similar hazards

**A2** Appliances shall not emit harmful radiation or present a toxic or similar hazard due to their operation in normal use.

Compliance is checked by the limits or tests specified in Part 2. However, if no limits or tests are specified in Part 2, then the appliance is deemed to comply with the requirement without testing. **A2**

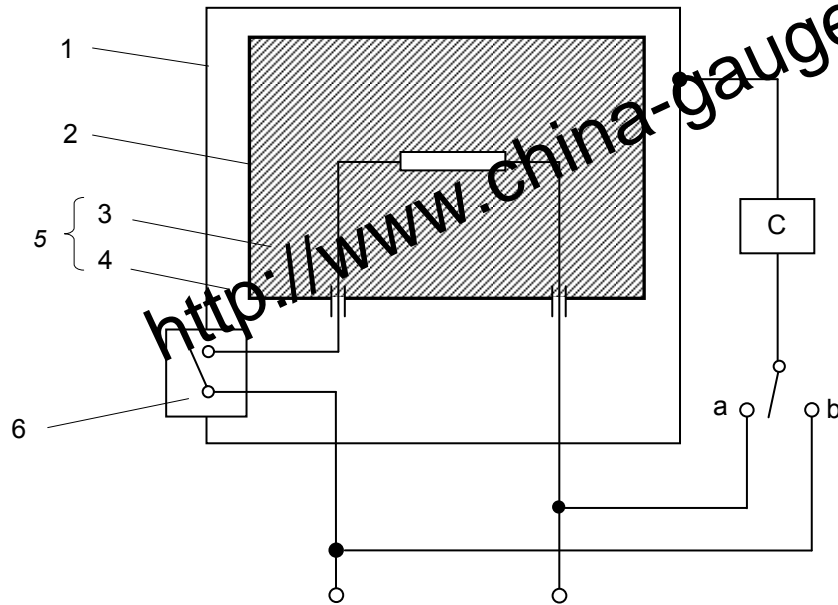

IEC 545/01

**Key**

- C Circuit of figure 4 of IEC 60990
- 1 **Accessible part**
- 2 Inaccessible metal part
- 3 **Basic insulation**
- 4 **Supplementary insulation**
- 5 **Double insulation**
- 6 **Reinforced insulation**

**Figure 1 – Circuit diagram for leakage current measurement at operating temperature for single-phase connection of class II appliances**

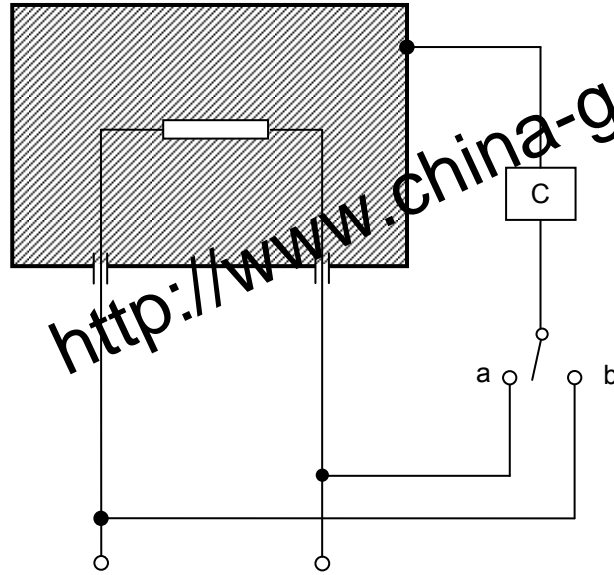

IEC 546/01

**Key**

C Circuit of figure 4 of IEC 60990

**Figure 2 – Circuit diagram for leakage current measurement at operating temperature for single-phase connection of appliances, other than those of class II**

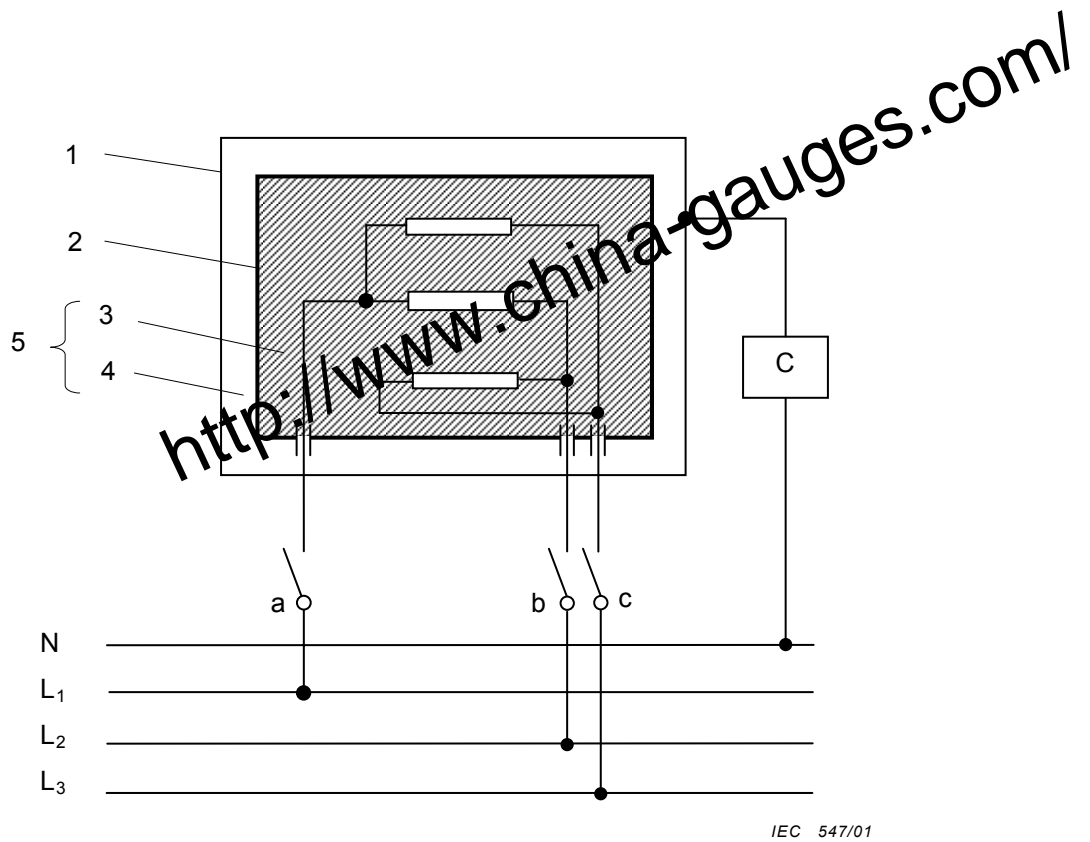

**Key**

- C Circuit of figure 4 of IEC 60990
- 1 **Accessible part**
- 2 Inaccessible metal part
- 3 **Basic insulation**
- 4 **Supplementary insulation**
- 5 **Double insulation**

**Connections and supplies**

- L<sub>1</sub>, L<sub>2</sub>, L<sub>3</sub>, N Supply voltage with neutral

**Figure 3 – Circuit diagram for leakage current measurement at operating temperature for three-phase connection of class II appliances**

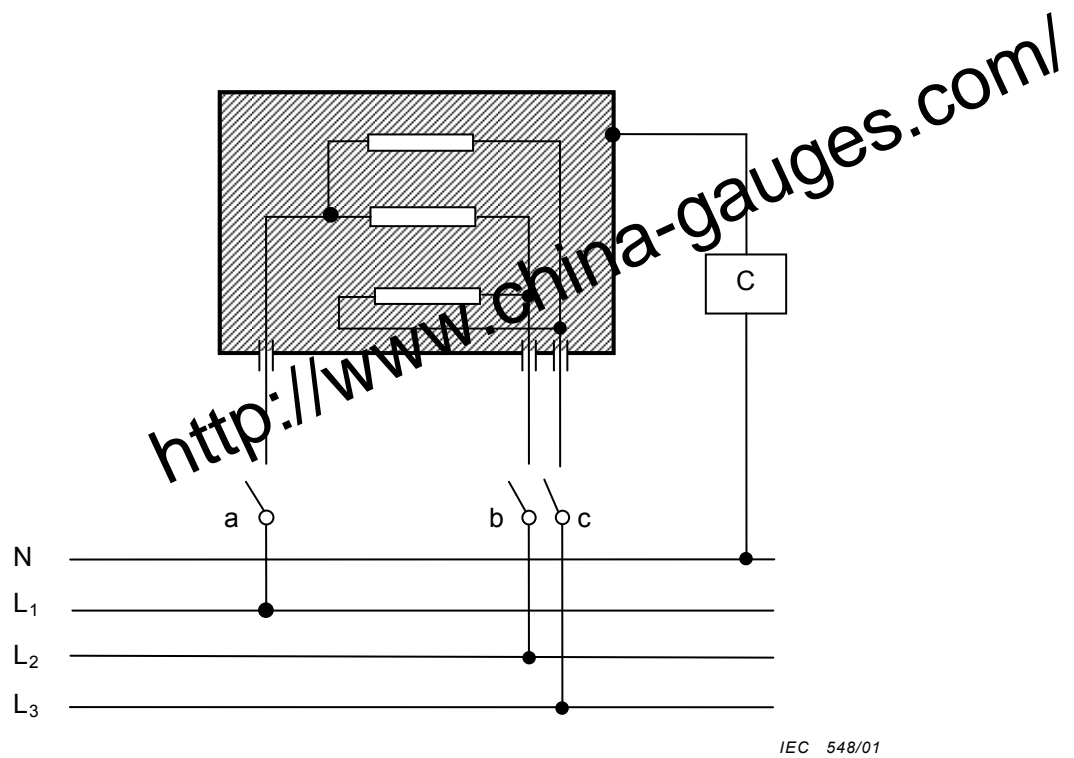

**Key**

C Circuit of figure 4 of IEC 60990

**Connections and supplies**

L<sub>1</sub>, L<sub>2</sub>, L<sub>3</sub>, N Supply voltage with neutral

**Figure 4 – Circuit diagram for leakage current measurement at operating temperature for three-phase connection of appliances other than those of class II**

**Figure 5 –** Void

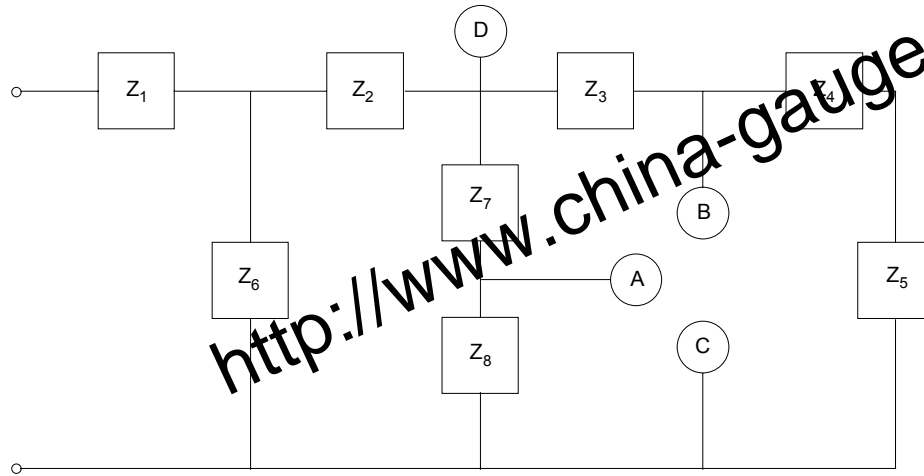

IEC 550/01

D is a point farthest from the supply source where the maximum power delivered to external load exceeds 15 W.

A and B are points closest to the supply source where the maximum power delivered to external load does not exceed 15 W. These are low-power points.

Points A and B are separately short-circuited to C.

The fault conditions a) to f) specified in 19.11.2 are applied individually to  $Z_1$ ,  $Z_2$ ,  $Z_3$ ,  $Z_6$  and  $Z_7$ , where applicable.

**Figure 6 – Example of an electronic circuit with low-power points**

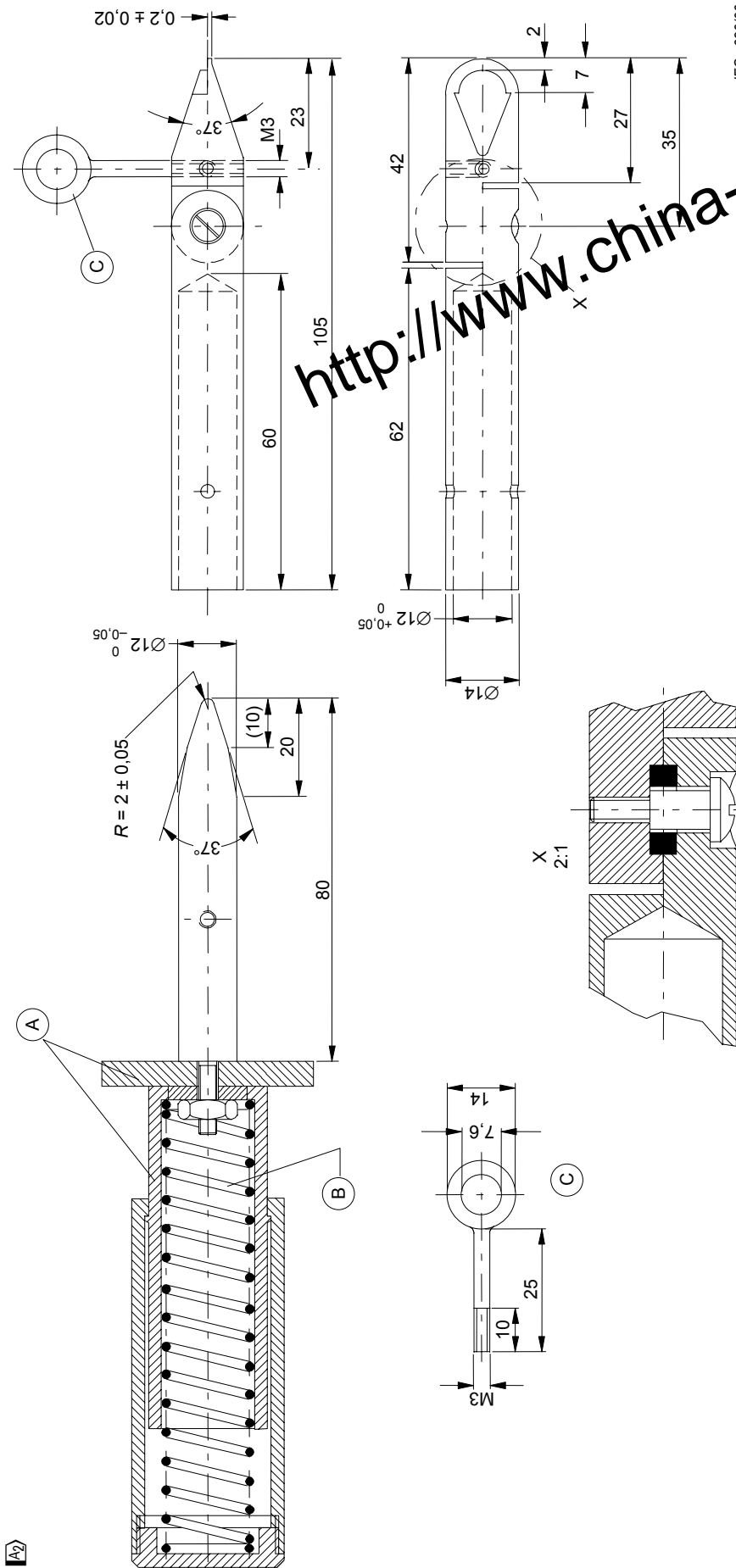

<http://www.china-gauges.com/>

Figure 7 – Test finger nail

**Key**

- A Insulating material
- B Spring with a constant suitable for providing a push force as specified in 22.11 on the test finger nail
- C Loop

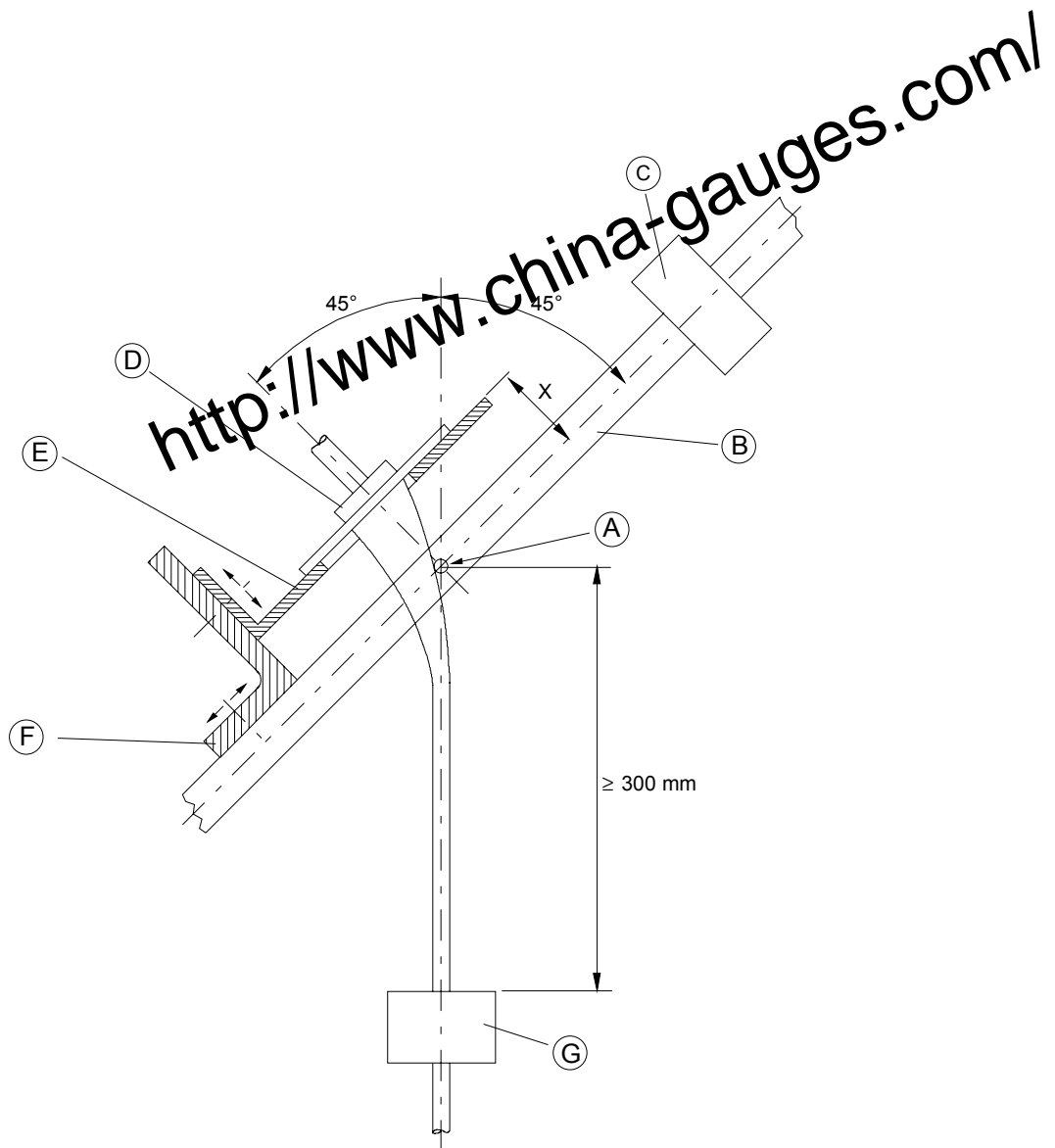

IEC 552/01

**Key**

- A Axis of oscillation
- B Oscillating frame
- C Counterweight
- D Sample
- E Adjustable carrier plate
- F Adjustable bracket
- G Load

**Figure 8 – Flexing test apparatus**



ACCEPTABLE CONSTRUCTIONS

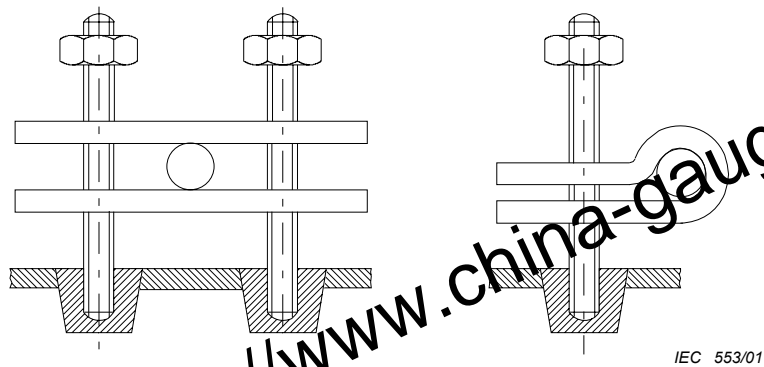

Construction showing studs securely attached to the appliance

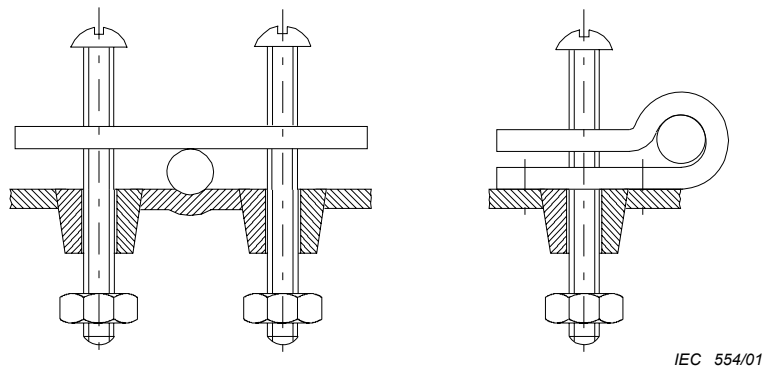

Construction showing part of appliance of insulating material and so shaped that it obviously forms part of a cord clamp.

Construction showing one of the clamping members is fixed to the appliance

NOTE Clamping screws may screw into threaded holes in the appliance or pass through holes where they are secured by nuts.

UNACCEPTABLE CONSTRUCTIONS

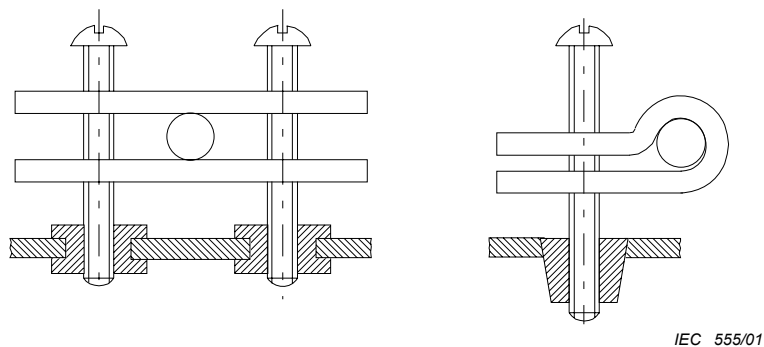

Construction showing no part securely fixed to the appliance.

NOTE Clamping screws may screw into threaded holes in the appliance or pass through holes where they are secured by nuts.

Figure 9 – Constructions of cord anchorages

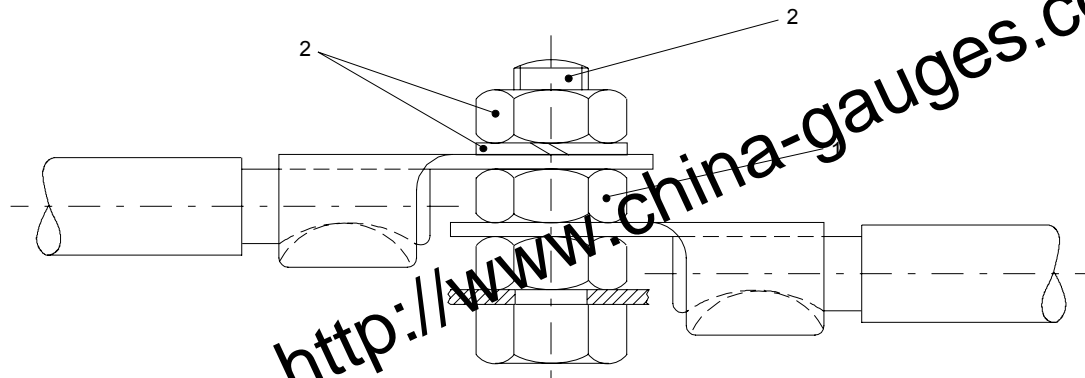

IEC 556/01

**Key**

- 1 Part providing earthing continuity
- 2 Part providing or transmitting contact pressure

**Figure 10 – An example of parts of an earthing terminal**

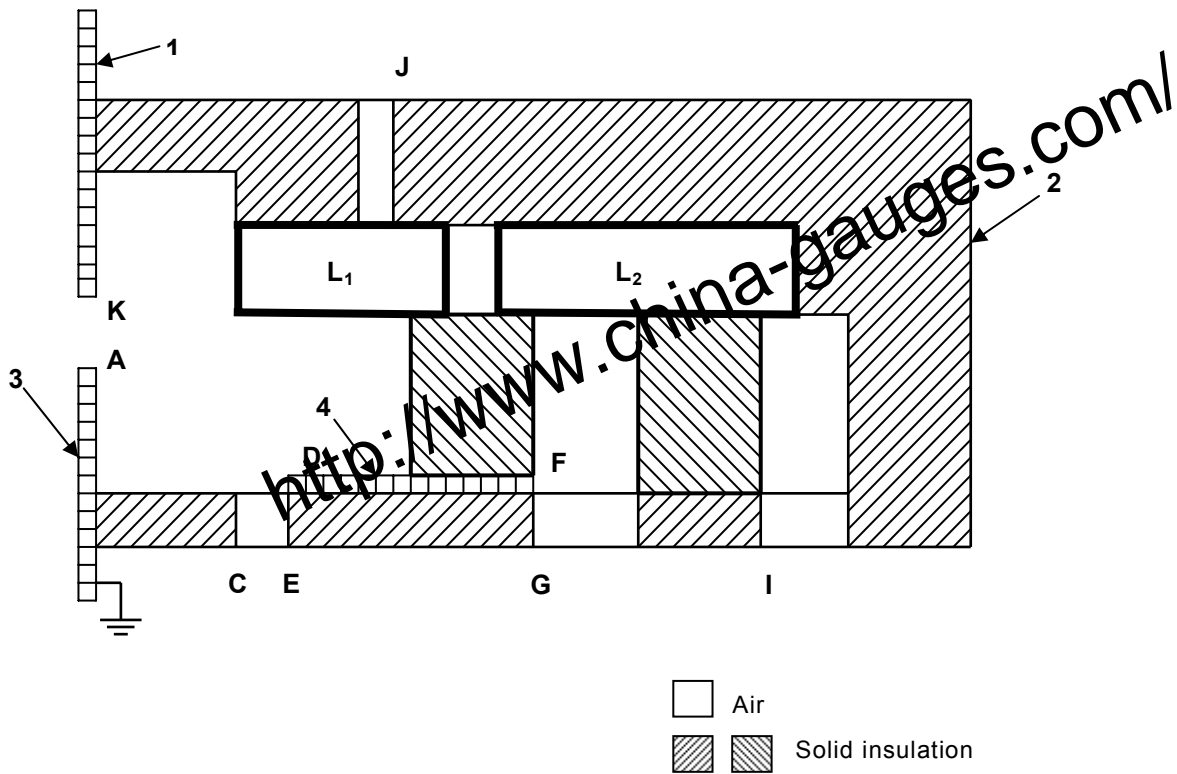

IEC 557/01

**Key**

- 1 Accessible unearthed metal part
- 2 Enclosure
- 3 Accessible earthed metal part
- 4 Inaccessible unearthed metal part

The **live parts**  $L_1$  and  $L_2$  are separated from each other and partially surrounded by a plastic enclosure containing apertures, partially by air and are in contact with solid insulation. A piece of inaccessible metal is incorporated inside the construction. There are two metal covers, one of which is earthed.

<u>Type of insulation</u>	<u>Clearance</u>
<b>Basic insulation</b>	$L_1A$
	$L_1D$
	$L_2F$
<b>Functional insulation</b>	$L_1L_2$
<b>Supplementary insulation</b>	DE
	FG
<b>Reinforced insulation</b>	$L_1K$
	$L_1J$
	$L_2I$
	$L_1C$

NOTE If the clearances  $L_1D$  or  $L_2F$  meet the clearance requirements for reinforced insulation, the clearances DE or FG of supplementary insulation are not measured.

**Figure 11 – Examples of clearances**

**Annex A**  
(informative)

**Routine tests**

**Introduction**

Routine tests are intended to be carried out by the manufacturer on each appliance to detect a production variation that could impair safety. They are normally carried out on the complete appliance after assembly but the manufacturer may perform the tests at an appropriate stage during production, provided that later manufacturing processes do not affect the results.

NOTE Components are not subjected to these tests if they have been previously subjected to routine tests during their manufacture.

The manufacturer may use a different routine test procedure provided that the level of safety is equivalent to that provided by the tests specified in this annex.

These tests are the minimum considered necessary to cover essential safety aspects. It is the manufacturer's responsibility to decide if additional routine tests are necessary. It may be determined from engineering considerations that some of the tests are impracticable or inappropriate and therefore need not be carried out.

If a product fails any of the tests, it is to be retested after rework or adjustment.

**A.1 Earth continuity test**

*A current of at least 10 A, derived from a source having a no-load voltage not exceeding 12 V (a.c. or d.c.), is passed between each of the **accessible earthed metal parts** and*

- *for **class 0I appliances**, and for **class I appliances** intended to be permanently connected to fixed wiring, the earthing terminal;*
- *for other **class I appliances**,*
  - *the earthing pin or earthing contact of the plug;*
  - *the earthing pin of the appliance inlet.*

*The voltage drop is measured and the resistance is calculated and shall not exceed*

- *for appliances having a **supply cord**, 0,2  $\Omega$ , or 0,1  $\Omega$  plus the resistance of the **supply cord**,*
- *for other appliances, 0,1  $\Omega$ .*

NOTE 1 The test is only carried out for the duration necessary to enable the voltage drop to be measured.

NOTE 2 Care is to be taken to ensure that the contact resistance between the tip of the measuring probe and the metal part under test does not influence the test results.

**A.2 Electric strength test**

*The insulation of the appliance is subjected to a voltage of substantially sinusoidal waveform having a frequency of approximately 50 Hz or 60 Hz for 1 s. The value of the test voltage and the points of application are shown in table A.1.*

Table A.1 – Test voltages

Points of application	Test voltage V		
	Class 0 appliances, Class 0I appliances, Class I appliances and Class II appliances		Class III appliances
	Rated voltage		
	≤150 V	>150 V	
Between live parts and accessible metal parts separated from live parts by			
• basic insulation only	800	1 000	400
• double or reinforced insulation <sup>a, b</sup>	2 000	2 500	–
<sup>a</sup> This test is not applicable for class 0 appliances. <sup>b</sup> For class 0I appliances and class I appliances, this test need not be carried out on parts of class II construction if the test is considered to be inappropriate.			

NOTE 1 It may be necessary for the appliance to be in operation during the test to ensure that the test voltage is applied to all relevant insulation, for example, heating elements controlled by a relay.

*No breakdown shall occur. Breakdown is assumed to occur when the current in the test circuit exceeds 5 mA. However, this limit may be increased up to 30 mA for appliances with a high leakage current.*

NOTE 2 The circuit used for the test incorporates a current sensing device that trips when the current exceeds the limit.

NOTE 3 The high voltage transformer is to be capable of maintaining the specified voltage at the limiting current.

NOTE 4 Instead of being subjected to an a.c. voltage, the insulation may be subjected to a d.c. voltage of 1,5 times the value shown in the table. An a.c. voltage having a frequency up to 5 Hz is considered to be a d.c. voltage.

### A.3 Functional test

*The correct functioning of an appliance is checked by inspection or by an appropriate test if the incorrect connection or adjustment of components has safety implications.*

NOTE Examples are verification of the correct direction of motor rotation and the appropriate operation of interlock switches. This does not require testing of thermal controls or **protective devices**.

**Annex B**  
(normative)

**Appliances powered by rechargeable batteries**

The following modifications to this standard are applicable for appliances powered by batteries that are recharged in the appliance.

NOTE This annex does not apply to battery chargers (EN 60335-2-29).

**3 Definitions**

**3.1.9**

**normal operation**

operation of the appliance under the following conditions:

- the appliance, supplied by its fully charged battery, is operated as specified in the relevant part 2;
- the battery is charged, the battery being initially discharged to such an extent that the appliance cannot operate;
- if possible, the appliance is supplied from the supply mains through its battery charger, the battery being initially discharged to such an extent that the appliance cannot operate. The appliance is operated as specified in the relevant part 2;
- if the appliance incorporates inductive coupling between two parts that are detachable from each other, the appliance is supplied from the supply mains with the **detachable part** removed.

**3.6.2**

NOTE If a part has to be removed in order to discard the battery before scrapping the appliance, this part is not considered to be detachable even if the instructions state that it is to be removed.

**5 General conditions for the tests**

**5.101** *When appliances are supplied from the supply mains, they are tested as specified for motor-operated appliances.*

**7 Marking and instructions**

**7.1** The battery compartment of appliances incorporating batteries that are intended to be replaced by the user shall be marked with the battery voltage and the polarity of the terminals.

NOTE 1 If colours are used, the positive terminal is to be identified in red and the negative terminal in black.

NOTE 2 Colour is not to be used as the only indication of polarity.

**7.12** The instructions shall give information regarding charging.

The instructions for appliances incorporating batteries that are intended to be replaced by the user shall include the following:

- the type reference of the battery;
- the orientation of the battery with regard to polarity;

- the method of replacing batteries;
- details regarding safe disposal of used batteries;
- warning against using non-rechargeable batteries;
- how to deal with leaking batteries.

The instructions for appliances incorporating a battery that contains materials that are hazardous to the environment shall give details on how to remove the battery and shall state that

- the battery must be removed from the appliance before it is scrapped;
- the appliance must be disconnected from the supply mains when removing the battery;
- the battery is to be disposed of safely.

**7.15** Markings, other than those associated with the battery, shall be placed on the part of the appliance that is connected to the supply mains.

## **8 Protection against access to live parts**

**8.2** Appliances having batteries that according to the instructions may be replaced by the user need only have **basic insulation** between **live parts** and the inner surface of the battery compartment. If the appliance can be operated without the batteries, **double insulation** or **reinforced insulation** is required.

## **11 Heating**

**11.7** *The battery is charged for the period stated in the instructions or for 24 h, whichever is longer.*

## **19 Abnormal operation**

**19.1** *Appliances are also subjected to the tests of 19.101, 19.102, and 19.103.*

**19.10** Not applicable.

**19.101** *Appliances are supplied at **rated voltage** for 168 h, the battery being continually charged during this period.*

**19.102** *For appliances having batteries that can be removed without the aid of a **tool**, and having terminals that can be short-circuited by a thin straight bar, the terminals of the battery are short-circuited, the battery being fully charged.*

**19.103** *Appliances having batteries that are replaceable by the user are supplied at **rated voltage** and operated under **normal operation** but with the battery removed or in any position allowed by the construction.*

## **21 Mechanical strength**

**21.101** Appliances having pins for insertion into socket-outlets shall have adequate mechanical strength.

*Compliance is checked by subjecting the part of the appliance incorporating the pins to the free fall test, procedure 2, of IEC 60068-2-32.*

*The number of falls is*

- 100, if the mass of the part does not exceed 250 g;
- 50, if the mass of the part exceeds 250 g.

*After the test, the requirements of 8.1, 15.1.1, 16.3 and clause 29 shall be met.*

## **22 Construction**

### **22.3**

NOTE Appliances having pins for insertion into socket-outlets are tested as fully assembled as possible.

## **25 Supply connection and external flexible cords**

**25.13** An additional lining or bushing is not necessary for **interconnection cords** operating at **safety extra-low voltage**.

## **30 Resistance to heat and fire**

**30.2** *For parts of the appliance that are connected to the supply mains during the charging period, 30.2.3 applies. For other parts, 30.2.2 applies.*



**Annex C**  
(normative)

**Ageing test on motors**

This annex is applicable when there is doubt with regard to the temperature classification of the insulation of a motor winding, for example

- if the temperature rise of the motor winding exceeds the values specified in table 3;
- when well-known insulating materials are used in an unconventional way;
- when combinations of materials of different temperature classes are used at a temperature higher than that allowed for the lowest class;
- when materials are used for which sufficient experience is not available, for instance in motors having integral core insulation.

This test is carried out on six samples of the motor.

*The rotor of each motor is locked and a current is passed individually through the rotor winding and the stator winding, this current being such that the temperature of the relevant winding is equal to the maximum temperature rise measured during the test of clause 11, increased by 25 K. This temperature is further increased by one of the values chosen from table C.1. The corresponding total time during which the current is passed is indicated in the table.*

**Table C.1 – Test conditions**

<b>Temperature increase K</b>	<b>Total time h</b>
$0 \pm 3$	$p^a$
$10 \pm 3$	$0,5 p$
$20 \pm 3$	$0,25 p$
$30 \pm 3$	$0,125 p$
NOTE The temperature increase chosen is selected by the manufacturer.	
<sup>a</sup> $p$ is 8 000 unless otherwise specified in the relevant part 2.	

*The total time is divided into four equal periods, each being followed by a period of 48 h during which the motor is subjected to the humidity test of 15.3. After the final humidity test, the insulation shall withstand the electric strength test of 16.3, but with the test voltage reduced to 50 % of the value specified.*

*After each of the four periods and before the subsequent humidity test, the leakage current of the insulating system is measured as specified in 13.2, any component not forming part of the insulation system under test being disconnected before the measurement is made.*

*The leakage current shall not exceed 0,5 mA.*

*Failure of only one of the six motors during the first of the four periods of the test is ignored.*

*If one of the six motors fails during the second, third or fourth period of the test, the remaining five motors are subjected to a fifth period followed by the humidity test and the electric strength test.*

*The remaining five motors shall complete the test.*

<http://www.china-gauges.com/>

**Annex D**  
(normative)

**A1 Thermal motor protectors**

This annex is applicable to appliances having motors that incorporate thermal motor protectors.

The appliance is supplied at rated voltage with the rotor of the motor locked.

The duration of the test is as follows:

- *motors having self-resetting thermal motor protectors are operated for 300 cycles or for 72 h, whichever occurs first, unless they are likely to be permanently subjected to the supply voltage in which case the duration is 432 h;*
- *motors having non-self-resetting thermal motor protectors are operated for 30 cycles, the thermal motor protector being reset as soon as possible after each operation, but in not less than 30 s;*

*During the test, temperatures shall not exceed the values specified in 19.7 and the appliance shall comply with 19.13. A1*

**A2** Note deleted **A2**

**Annex E**  
(normative)

**Needle flame test**

The needle-flame test is carried out in accordance with EN 60335-11-5 with the following modifications.

**7 Severities**

*Replacement:*

*The duration of application of the test flame is 30 s ± 1 s.*

**9 Test procedure**

**9.1 Position of test specimen**

*Modification:*

*The specimen is arranged so that the flame can be applied to a vertical or horizontal edge as shown in the examples of Figure 1.*

**9.2 Application of needle-flame**

*Modification:*

*The first paragraph does not apply.*

*Addition:*

*If possible, the flame is applied at least 10 mm from a corner.*

**9.3 Number of test specimens**

*Replacement:*

*The test is carried out on one specimen. If the specimen does not withstand the test, the test may be repeated on two additional specimens, both of which shall then withstand the test.*

**11 Evaluation of test results**

*Addition:*

*The duration of burning ( $t_b$ ) shall not exceed 30 s. However, for printed circuit boards, the duration of burning shall not exceed 15 s. <sup>(A2)</sup>*

**Annex F**  
(normative)

**Capacitors**

Capacitors likely to be permanently subjected to the supply voltage, and used for radio interference suppression or for voltage dividing, shall comply with the following clauses of IEC 60384-14, as modified below.

SECTION ONE – GENERAL

**1.5 Terminology**

**1.5.3** This subclause is applicable.

Class X capacitors are tested according to subclass X2.

**1.5.4** This subclause is applicable.

**1.6 Marking**

Items a) and b) of this subclause are applicable.

SECTION THREE – QUALITY ASSESSMENT PROCEDURES

**3.4 Approval testing**

**3.4.3.2 Tests**

Table II is applicable as follows:

- group 0: subclauses 4.1, 4.2.1 and 4.2.5;
- group 1A: subclause 4.1.1;
- group 2: subclause 4.12;
- group 3: subclauses 4.13 and 4.14;
- group 6: subclause 4.17;
- group 7: subclause 4.18.

SECTION FOUR – TEST AND MEASUREMENT PROCEDURES

**4.1 Visual examination and check of dimensions**

This subclause is applicable.

**4.2 Electrical tests**

**4.2.1** This subclause is applicable.

**4.2.5** This subclause is applicable.

**4.2.5.2** Only table IX is applicable. The values for test A apply; however, for capacitors in **heating appliances** the values for test B or test C apply.

#### **4.12 Damp heat, steady state**

This subclause is applicable.

NOTE Only insulation resistance and voltage proof are checked (see table XIII).

#### **4.13 Impulse voltage**

This subclause is applicable.

#### **4.14 Endurance**

Subclauses 4.14.1, 4.14.3, 4.14.4 and 4.14.7 are applicable.

##### **4.14.7 Add:**

NOTE Only insulation resistance and voltage proof are checked (see table XIV) together with a visual examination to ensure that there is no visible damage.

#### **4.17 Passive flammability test**

This subclause is applicable.

#### **4.18 Active flammability test**

This subclause is applicable.

<http://www.china-gauges.com/>

**Annex G**  
(normative)

**Safety isolating transformers**

The following modifications to this standard are applicable for safety isolating transformers.

**7 Marking and instructions**

7.1 Transformers for specific use shall be marked with

- name, trade mark or identification mark of the manufacturer or responsible vendor;
- model or type reference.

NOTE The definition of transformers for specific use is given in IEC 61558-1.

**17 Overload protection of transformers and associated circuits**

*Fail-safe transformers shall comply with subclause 15.5 of IEC 61558-1.*

NOTE This test is carried out on three transformers.

**22 Construction**

Subclauses 19.1 and 19.1.2 of IEC 61558-2-6 are applicable.

**29 Clearances, creepage distances and solid insulation**

**29.1, 29.2 and 29.3** The distances specified in items 2a, 2c and 3 in table 13 of IEC 61558-1 apply.

NOTE The values stated for pollution degree 2 are applicable.

## Annex H (normative)

### Switches

Switches shall comply with the following clauses of IEC 61058-1, as modified below.

The tests of IEC 61058-1 are carried out under the conditions occurring in the appliance.

Before being tested, switches are operated 20 times without load.

#### 8 Marking and documentation

Switches are not required to be marked. However, a switch that can be tested separately from the appliance shall be marked with the manufacturer's name or trade mark and the type reference.

#### 13 Mechanism

NOTE The tests may be carried out on a separate sample.

#### 15 Insulation resistance and dielectric strength

Subclause 15.1 is not applicable.

Subclause 15.2 is not applicable.

Subclause 15.3 is applicable for full disconnection and micro-disconnection.

NOTE This test is carried out immediately after the humidity test of subclause 15.3 of IEC 60335-1.

#### 17 Endurance

*Compliance is checked on three separate appliances or switches.*

*For 17.2.4.4, the number of cycles of actuation declared according to 7.1.4 is 10 000 unless otherwise specified in subclause 24.1.3 of the relevant part 2 of IEC 60335.*

*Switches intended for operation under no load and which can be operated only with the aid of a **tool** are not subjected to the tests. This applies also for such switches operated by hand that are interlocked so that they cannot be operated under load. However, switches without this interlock are subjected to the test of 17.2.4.4 for 100 cycles of operation.*

**A1** Subclauses 17.2.2 and 17.2.5.2 are not applicable. The ambient temperature during the test is that occurring in the appliance during the test of Clause 11 in IEC 60335-1, as specified in footnote b of Table 3. **A1**

*At the end of the tests, the temperature rise of the terminals shall not have increased by more than 30 K above the temperature rise measured in clause 11 of IEC 60335-1.*



**20 Clearances, creepage distances, solid insulation and coatings of rigid printed board assemblies**

This clause is applicable to **clearances** and **creepage distances** for functional insulation, across full disconnection and micro-disconnection, as stated in table 24.

<http://www.china-gauges.com/>

**Annex I**  
(normative)

**Motors having basic insulation that is inadequate for the rated voltage of the appliance**

The following modifications to this standard are applicable for motors having **basic insulation** that is inadequate for the **rated voltage** of the appliance.

**8 Protection against access to live parts**

**8.1** NOTE Metal parts of the motor are considered to be bare **live parts**.

**11 Heating**

**11.3** *The temperature rise of the body of the motor is determined instead of the temperature rise of the windings.*

**11.8** *The temperature rise of the body of the motor, where it is in contact with insulating material, shall not exceed the values shown in table 3 for the relevant insulating material.*

**16 Leakage current and electric strength**

**16.3** *The insulation between **live parts** of the motor and its other metal parts is not subjected to this test.*

**19 Abnormal operation**

**19.1** *The tests of 19.7 to 19.9 are not carried out.*

*Appliances are also subjected to the test of 19.101.*

**19.101** *The appliance is operated at **rated voltage** with each of the following fault conditions:*

- *short circuit of the terminals of the motor, including any capacitor incorporated in the motor circuit;*
- *short circuit of each diode of the rectifier;*
- *open circuit of the supply to the motor;*
- *open circuit of any parallel resistor, the motor being in operation.*

*Only one fault is simulated at a time, the tests being carried out consecutively.*

NOTE The faults are simulated as shown in figure I.1.

## 22 Construction

**22.101** For **class I appliances** incorporating a motor supplied by a rectifier circuit, the d.c. circuit shall be insulated from **accessible parts** of the appliance by **double insulation** or **reinforced insulation**.

*Compliance is checked by the tests specified for **double insulation** and **reinforced insulation**.*

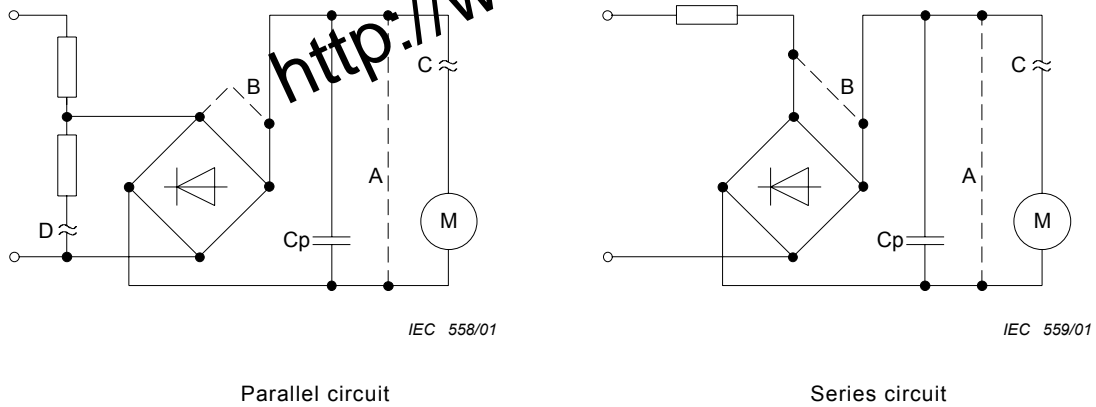

### Key

- Original connection
- - - Short-circuit
- ≈ Open circuit
- A Short-circuit of the terminals of the motor
- B Short-circuit of a diode
- C Open circuit of the supply to the motor
- D Open circuit of the parallel resistor

**Figure I.1 – Simulation of faults**

**Annex J**  
(normative)

**Coated printed circuit boards**

The testing of protective coatings of printed circuit boards is carried out in accordance with IEC 60664-3 with the following modifications.

**5.7 Conditioning of the test specimens**

When production samples are used, three samples of the printed circuit board are tested.

**5.7.1 Cold**

The test is carried out at  $-25\text{ }^{\circ}\text{C}$ .

**5.7.3 Rapid change of temperature**

Severity 1 is specified.

**5.9 Additional tests**

This subclause is not applicable. **A2**

**Annex K**  
(normative)

**Overvoltage categories**

The following information on overvoltage categories is extracted from IEC 60664-1.

Overvoltage category is a numeral defining a transient overvoltage condition.

Equipment of overvoltage category I is for use at the origin of the installation.

NOTE 1 Examples of such equipment are electricity meters and primary overcurrent protection equipment.

Equipment of overvoltage category III is equipment in fixed installations and for cases where the reliability and the availability of the equipment is subject to special requirements.

NOTE 2 Examples of such equipment are switches in the fixed installation and equipment for industrial use with permanent connection to the fixed installation.

Equipment of overvoltage category II is energy consuming equipment to be supplied from the fixed installation.

NOTE 3 Examples of such equipment are appliances, portable tools and other household and similar loads.

If such equipment is subjected to special requirements with regard to reliability and availability, overvoltage category III applies.

Equipment of overvoltage category I is equipment for connection to circuits in which measures are taken to limit transient overvoltages to an appropriately low level.

NOTE 4 Examples are protected electronic circuits.

**Annex L**  
 (informative)

**Guidance for the measurement of clearances and creepage distances**

L.1 When measuring **clearances**, the following applies.

The **rated voltage** and overvoltage category are determined (see annex K).

NOTE In general, appliances are in overvoltage category II.

The **rated impulse voltage** is determined from table 15.

If pollution degree 3 is applicable, or if the appliance is **class 0** or **class 01**, the **clearances** for **basic insulation** and **functional insulation** are measured and compared with the minimum values specified in table 16. For other cases, the impulse voltage test may be carried out if the rigidity requirements of 29.1 are met, otherwise the values specified in table 16 apply.

**Clearances** of **supplementary insulation** and **reinforced insulation** are measured and compared with the minimum values specified in table 16.

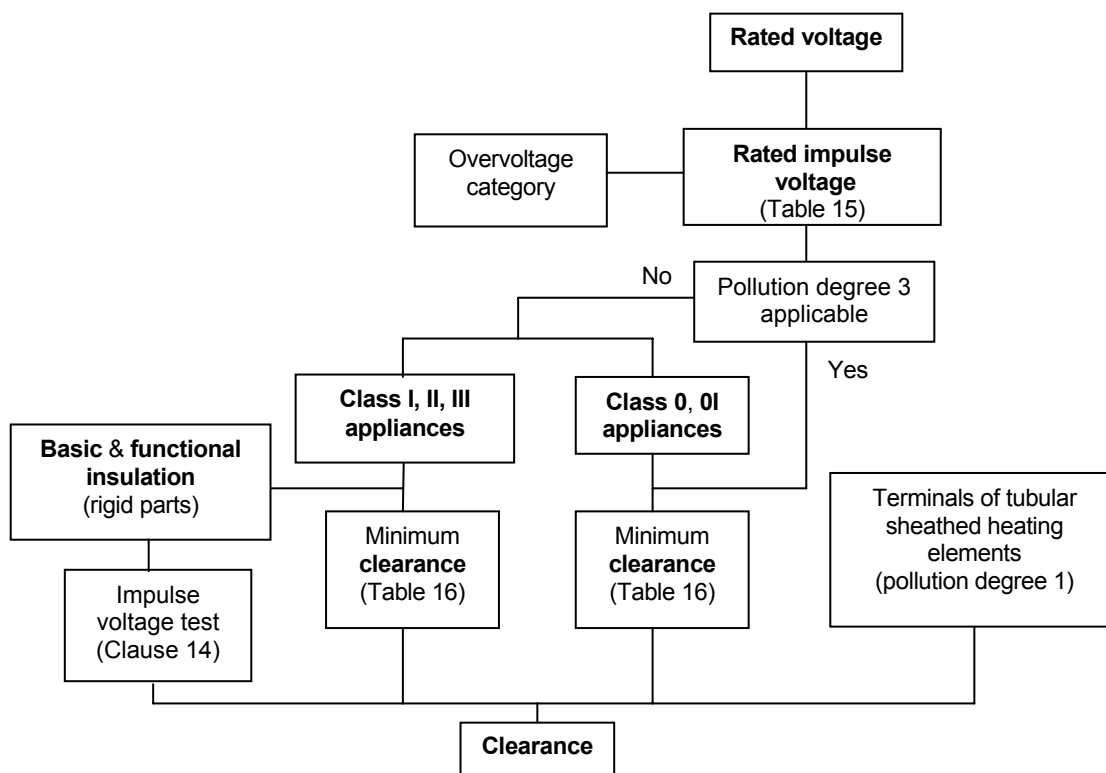

IEC 560/01

Figure L.1 – Sequence for the determination of clearances

L.2 When measuring **creepage distances**, the following applies.

The **working voltage**, pollution degree and material group are determined.

The **creepage distances** of **basic insulation** and **supplementary insulation** are measured and compared with the minimum values specified in table 17. A particular **creepage distance** is then compared with the corresponding **clearance** of table 16 and enlarged if necessary in order not to be less than the **clearance**. For pollution degree 1, the reduced **clearance** based on the impulse voltage test can be used. However, the **creepage distance** can not be less than the values of table 17.

The **creepage distances** of **functional insulation** are measured and compared with the minimum values specified in table 18.

The **creepage distances** of **reinforced insulation** are measured and compared with twice the minimum values specified in table 17.

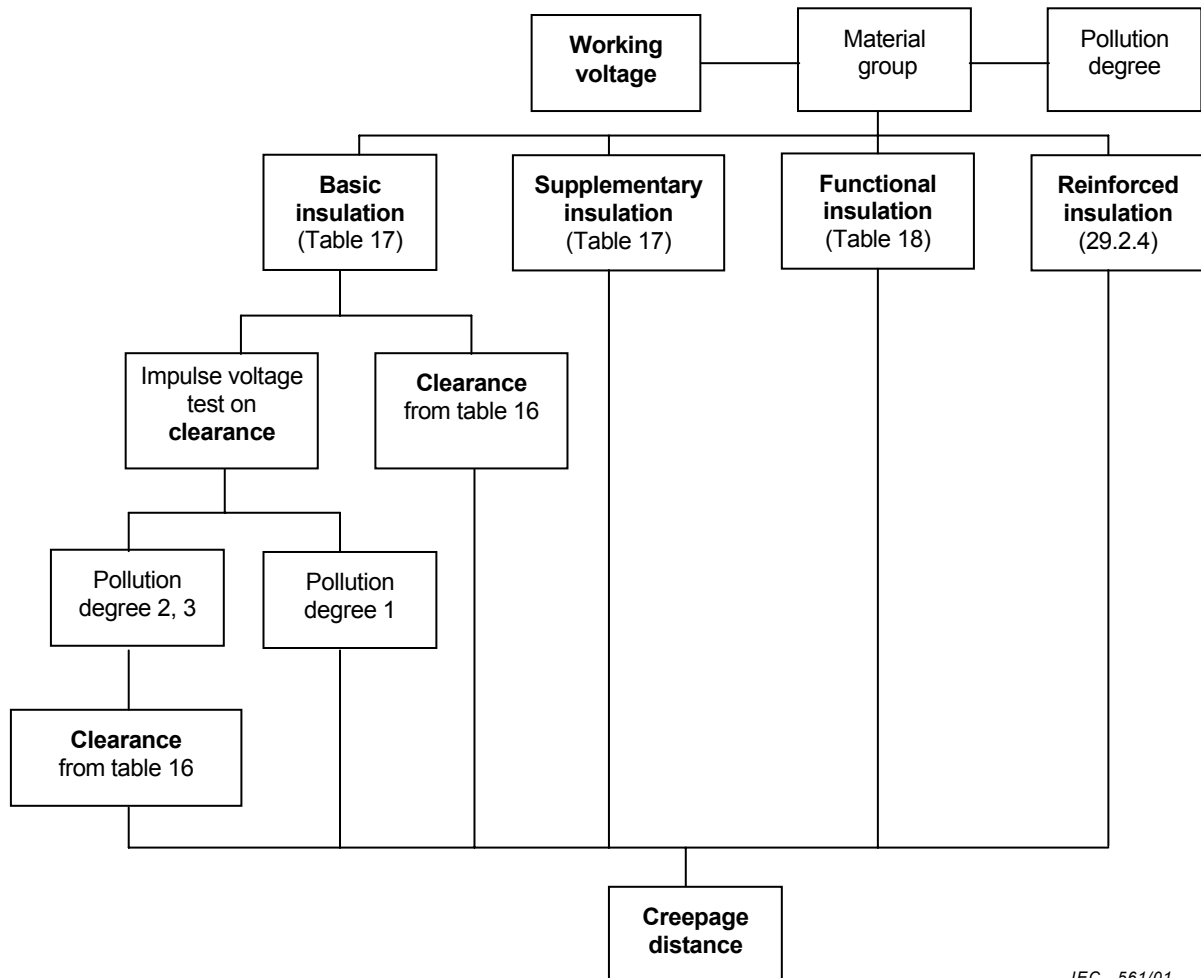

IEC 561/01

Figure L.2 – Sequence for the determination of creepage distances

**Annex M**  
(normative)

**Pollution degree**

The following information on pollution degrees is extracted from IEC 60664-1.

**Pollution**

The microenvironment determines the effect of pollution on the insulation. The macro-environment, however, has to be taken into account when considering the microenvironment.

Means may be provided to reduce pollution at the insulation under consideration by effective use of enclosures, encapsulation or hermetic sealing. Such means to reduce pollution may not be effective when the equipment is subjected to condensation or if in normal use, it generates pollutants itself.

Small **clearances** can be bridged completely by solid particles, dust and water and therefore minimum **clearances** are specified where pollution may be present in the microenvironment.

NOTE 1 Pollution will become conductive in the presence of humidity. Pollution caused by contaminated water, soot, metal or carbon dust is inherently conductive.

NOTE 2 Conductive pollution by ionized gases and metallic depositions occur only in specific instances, for example in arc chambers of switchgear or controlgear and is not covered by IEC 60664-1.

**Degrees of pollution in the microenvironment**

For the purpose of evaluating **creepage distances**, the following four degrees of pollution in the microenvironment are established

- pollution degree 1: no pollution or only dry, non-conductive pollution occurs. The pollution has no influence;
- pollution degree 2: only non-conductive pollution occurs, except that occasionally a temporary conductivity caused by condensation is to be expected;
- pollution degree 3: conductive pollution occurs or dry non-conductive pollution occurs that becomes conductive due to condensation that is to be expected;
- pollution degree 4: the pollution generates persistent conductivity caused by conductive dust or by rain or snow.

NOTE 3 Pollution degree 4 is not applicable to appliances.



**Annex N**  
(normative)

**Proof tracking test**

**A1)** The proof tracking test is carried out in accordance with IEC 60112 with the following modifications.

**7 Test apparatus**

**7.3 Test solutions**

*Test solution A is used.*

**10 Determination of proof tracking index (PTI)**

**10.1 Procedure**

*Modification:*

*The proof voltage is 100 V, 175 V, 400 V or 600 V, as appropriate.*

*The last paragraph of Clause 3 applies.*

*The test is carried out on five specimens.*

*In case of doubt, a material is considered to have a PTI of the specified value if it withstands the test at a voltage equal to the proof voltage reduced by 25 V, the number of drops being increased to 100.*

**10.2 Report**

*Addition:*

*The report shall state if the PTI value was based on a test using 100 drops with a test voltage of (PTI-25) V. **A1)***

**Annex O**  
 (informative)

**Selection and sequence of the tests of clause 30**

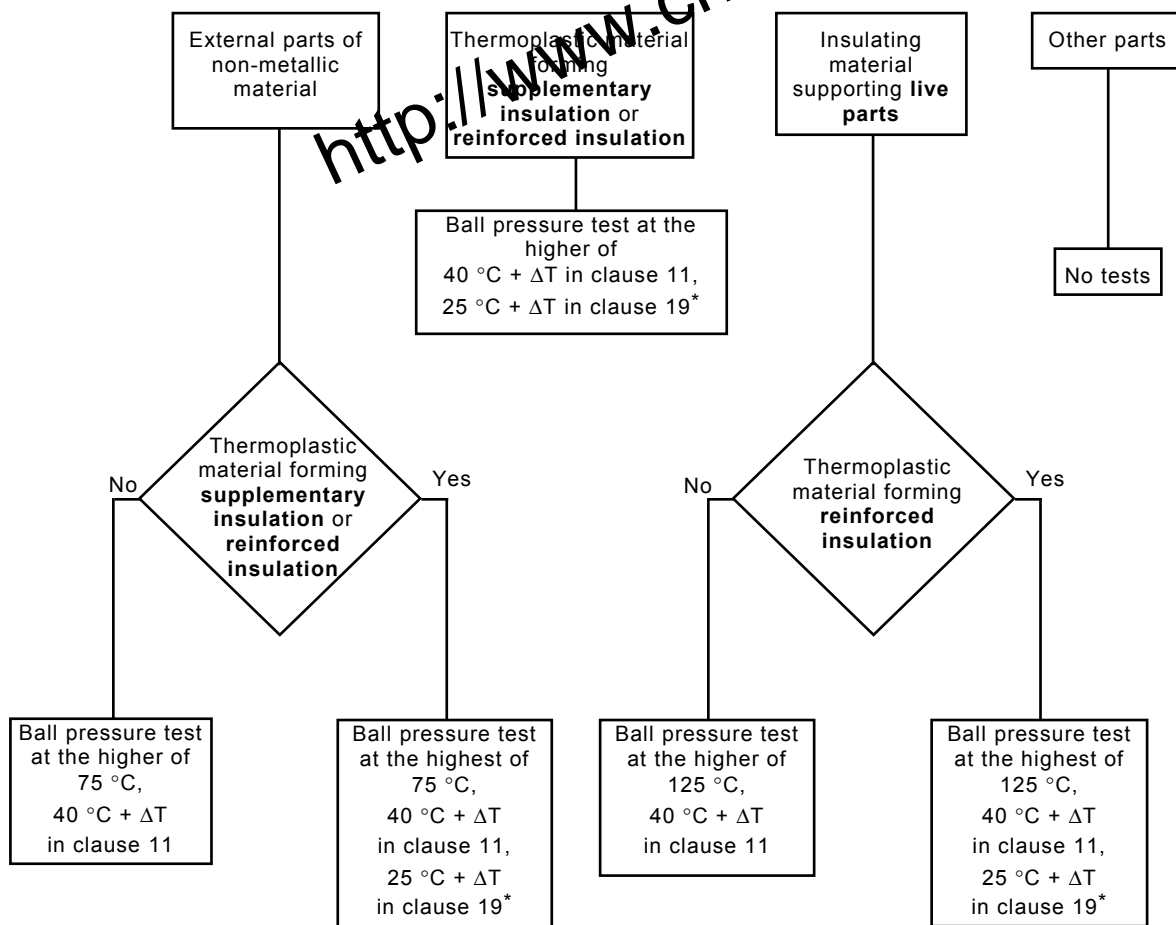

IEC 562/01

\*ΔT is not taken into account if the test of 19.4 is terminated by the operation of a **non-self-resetting protective device** requiring the use of a **tool** or removal of a cover to reset it.

**Figure O.1 – Tests for resistance to heat**

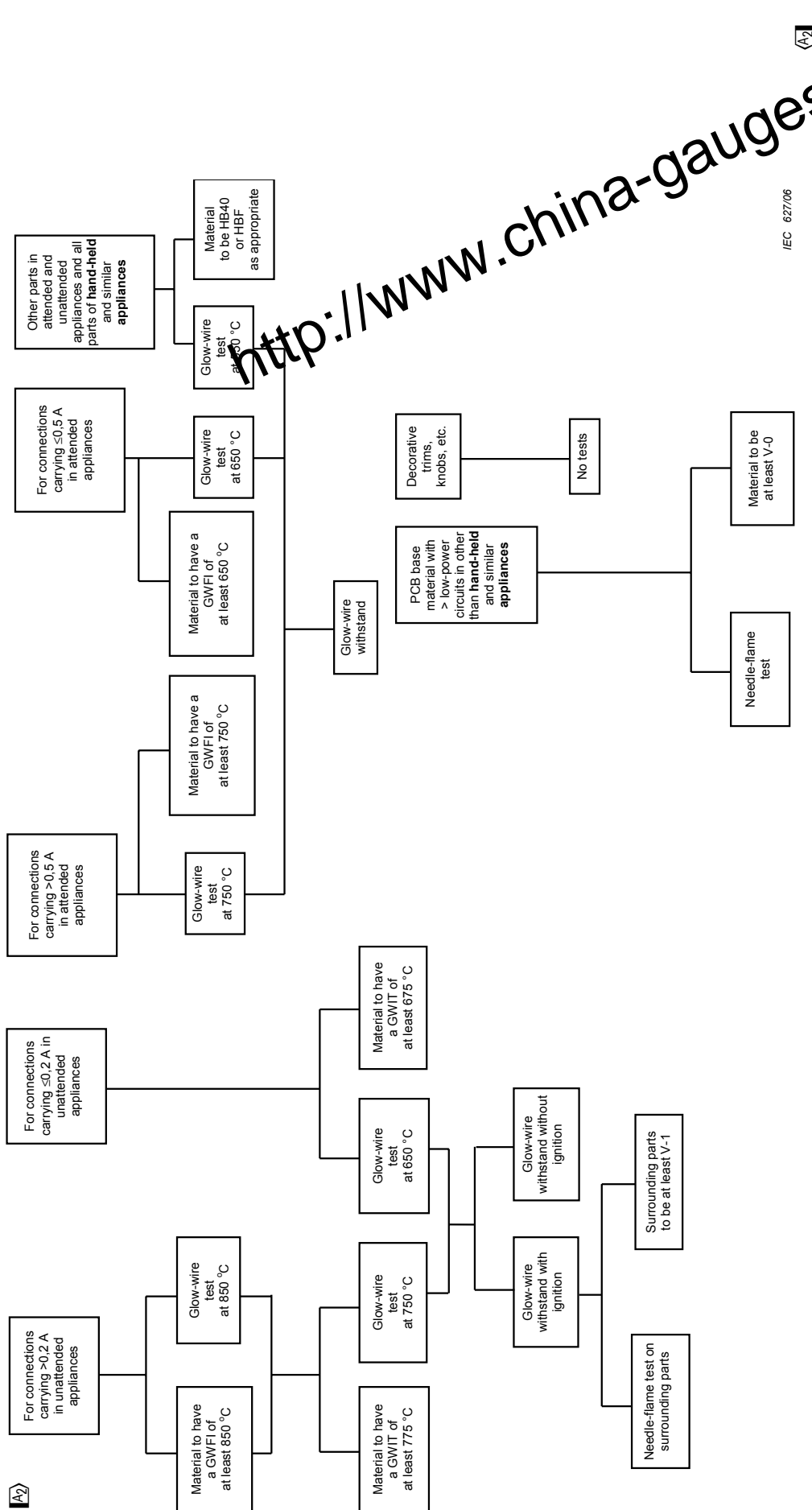

IEC 627/06

Figure O.2 – Tests for resistance to fire

<http://www.china-gauges.com/>

**Annex P**  
(informative)

**Guidance for the application of this standard to appliances  
used in warm damp equable climates**

The following modifications to this standard are applicable for **class 0 appliances** and **class OI appliances** having a **rated voltage** exceeding 150 V, that are intended to be used in countries having a warm damp equable climate and that are marked WDaE.

NOTE Warm damp equable climates are characterized by high humidity and high ambient temperatures with little variation, as specified in IEC 60721-2-1.

They may also be applied to **class I appliances** having a **rated voltage** exceeding 150 V that are intended to be used in countries having a warm damp equable climate and that are marked WDaE, if they are liable to be connected to a supply mains that excludes the protective earthing conductor due to deficiencies in the fixed wiring system.

## 5 General conditions for the tests

5.7 The ambient temperature for the tests of Clauses 11 and 13 is  $40^{+3}_0$  °C.

## 7 Marking and instructions

7.1 The appliance shall be marked with the letters WDaE.

7.12 The instructions shall state that the appliance is to be supplied through a residual current device (RCD) having a rated residual operating current not exceeding 30 mA.

The instructions shall state the substance of the following:

This appliance is considered to be suitable for use in countries having a warm damp equable climate. It may also be used in other countries.

## 11 Heating

11.8 The values of Table 3 are reduced by 15 K.

## 13 Leakage current and electric strength at operating temperature

13.2 The leakage current for **class I appliances** shall not exceed 0,5 mA.

## 15 Moisture resistance

15.3 The value of  $t$  is 37 °C.  $\square_{A1}$

**16** Leakage current and electric strength

**16.2** *The leakage current for class I appliances shall not exceed 0,5 mA.*

**19** Abnormal operation

**19.13** *The leakage current test of 16.2 is applied in addition to the electric strength test of 16.3.*

<http://www.china-gauges.com/>

**A1** Annex Q  
 (informative)

**Sequence of tests for the evaluation of electronic circuits**

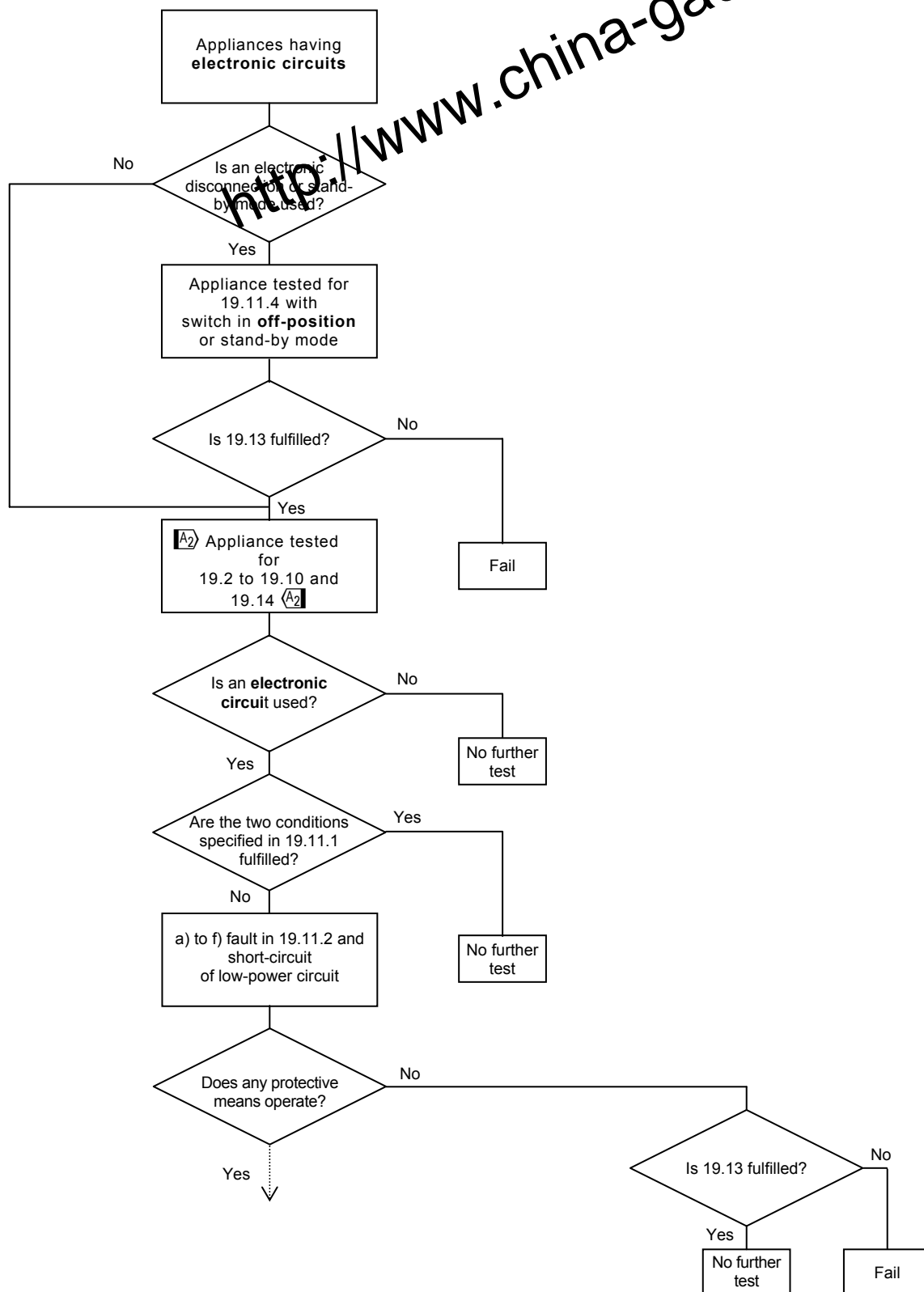

**A1) Sequence of tests for the evaluation of electronic circuits –  
 (continuation)**

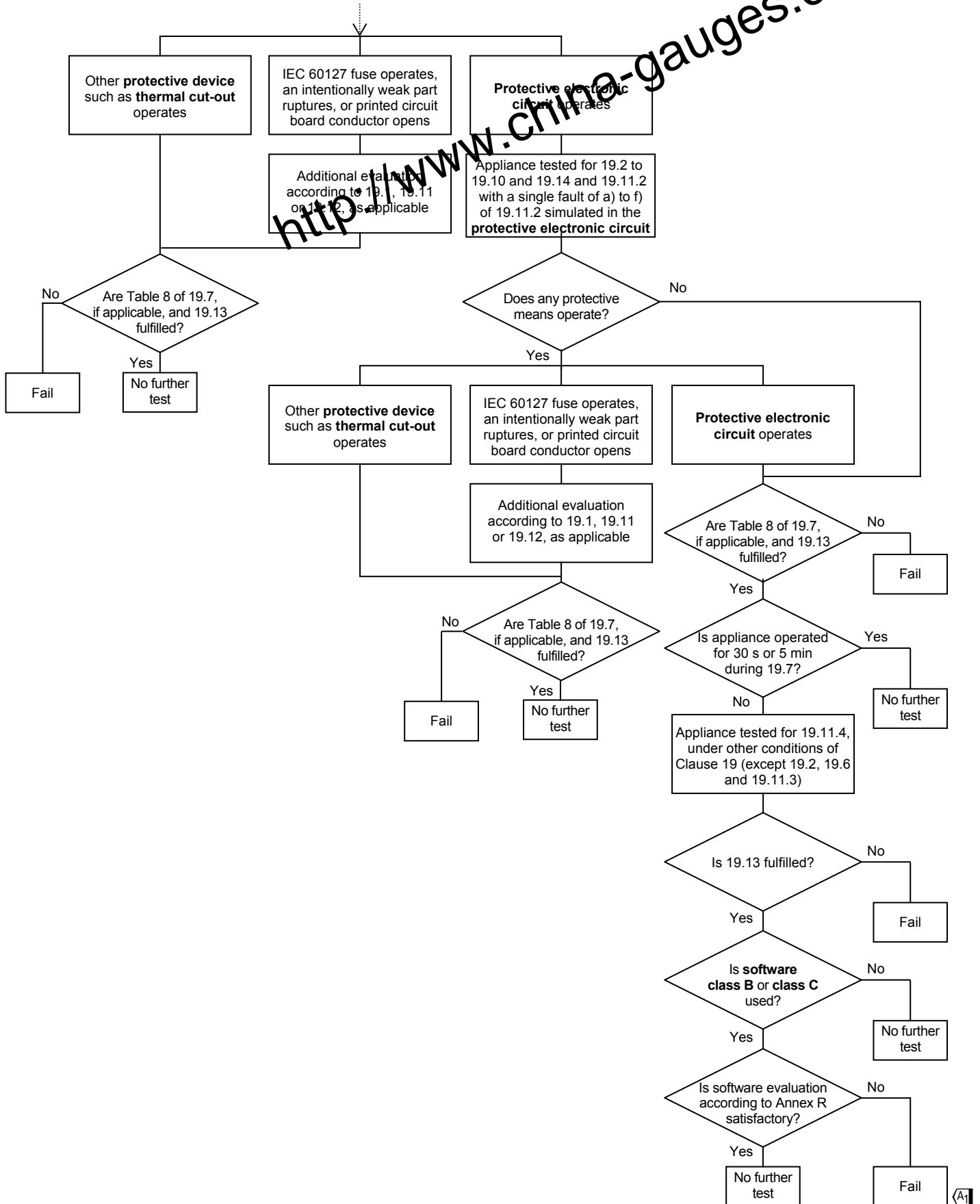

**Annex R**  
(normative)

**Software evaluation**

Software shall be evaluated in accordance with the following clauses of Annex H of IEC 60730-1, as modified below.

**H.2 Definitions**

Only definitions H.2.16 to H.2.20 are applicable.

**H.7 Information**

Only footnotes 12) to 16) and 18) of Table 7.2 are applicable.

*In footnote 15), replace “the requirements of 17, 25, 26 and 27” by “19.13 of IEC 60335-1” and replace “H.27” by “19.11.2 of IEC 60335-1”.*

**H.11.12 Controls using software**

All of the subclauses of H.11.12 as modified below are applicable, except subclauses H.11.12.6 and H.11.12.6.1 which are not applicable.

*In the second paragraph, replace “required in items 66 to 72 inclusive” by “referred to in footnotes 12) to 16) and 18) inclusive”.*

**H.11.12.7** *Delete “and identified in table 7.2, requirement 68”.*

**H.11.12.7.1** *Replace the text by the following:*

For appliances using **software class C** having a single channel with self-test and monitoring structure, the manufacturer shall provide the measures necessary to address the fault/errors in safety related segments and data indicated in Table H.11.12.7-1.

**H.11.12.8** *Replace the text by the following:*

Software fault/error detection shall occur before compliance with 19.13 of IEC 60335-1 is impaired.

**H.11.12.8.1** *Replace “result in the response declared in table 7.2, requirement 72” by “occur before compliance with 19.13 of IEC 60335-1 is impaired”.*

**H.11.12.13** *Replace the text by the following:*

The software and safety related hardware under its control shall initialize and terminate before compliance with 19.13 of IEC 60335-1 is impaired. **Annex R**



**Annex ZA**  
(normative)

**Special national conditions**

**Special national condition:** National characteristic or practice that cannot be changed even over a long period, e.g. climatic conditions, electrical earthing conditions. If it affects harmonization, it forms part of the European Standard or Harmonization Document.

For the countries in which the relevant special national conditions apply, these provisions are normative. For other countries they are informative.

Clause      Special national condition

**7.12**      **Denmark**

Supply cords of class I appliances, which are delivered without a plug, shall be provided with a visible tag with the following text:

Vigtigt !

Ledere med grøn/gul isolation  
må kun tilsluttes en klemme mærket



Important !

The conductor having green/yellow insulation  
shall only be connected to a terminal marked



If it is essential for the safety of the appliance, the tag shall be provided with a diagram showing the connection of the other conductors or with the following text:

For tilslutning af de øvrige ledere,  
se medfølgende installationsvejledning.

For the connection of the other conductors,  
see the enclosed instructions for installation.

**19.5**      **Norway**

The test is also applicable to appliances intended to be permanently connected to fixed wiring.

**22.2**      **France and Norway**

The second paragraph of this subclause, that deals with single-phase, permanently connected class I appliances having heating elements, is not applicable due to the supply system.

- 25.6** Plugs according to standard sheet C 2b are not allowed in Belgium, France, Spain and the United Kingdom.

Plugs according to standard sheet C 3b are not allowed in Austria, Finland, Germany, Iceland, Ireland, Italy, Luxembourg, Netherlands, Norway, Portugal, Spain, Sweden, Switzerland and the United Kingdom.

#### Denmark

Replace the common modification by the following:

Supply cords of single-phase portable appliances having a rated current not exceeding 13 A shall be provided with a plug according to the following:

- Class I appliances..... Section 107-2-D1, ed. 3, 1998  
Standard Sheet DK 2-1a

For appliances covered by a part 2 of EN 60335, it is also allowed until further notice, and unless otherwise specified, to use plugs in accordance with Section 107-2-D1, ed. 3, 1998, Standard Sheet C 2b, C 3b or C 4.

- Class II appliances..... Section 107-2-D1, ed. 3, 1998  
Standard Sheet C 1b, C 5, C 6,  
DKA 2-1a and DKA 2-1b

If stationary single-phase appliances having a rated current not exceeding 13 A are provided with a supply cord and a plug, the plug shall be in accordance with the requirements specified above.

If multi-phase appliances and single-phase appliances having a rated current exceeding 13 A are provided with a supply cord and a plug, the plug shall comply with the following table:

Class	Plug	
	Section 107-2-D1 Standard sheet	EN 60309-2 Standard sheet
I	DK 6-1a	2-II, 2-IV
II	DK 6-1a*	2-II, 2-IV*

\* Earthing contact not connected.

NOTE These plugs are also allowed for appliances having a rated current equal to or less than 13 A.

The maximum current for the plugs is as follows:

C5	: 2,5 A
DKA 2-1a and 1b	: 10 A
DK 2-1a	: 13A
C 1b and C 6	: 16 A
C 2b	: 16 A
C 3b	: 16 A
C 4	: 16 A

#### Ireland

Only plugs according to standard sheets B2 and C5 are allowed (see also Annex ZB).

#### Italy

Only plugs listed in CENELEC Report R0BT-005:2001 are allowed.

### Spain

For appliances for household use, only the following plugs are allowed:

- according to UNE 20315: ESC 10-1b, C2b, C4, C6 or ESB 25-5b;
- according to UNE-EN 50075.

### Switzerland

Supply cords of portable household and similar electrical appliances having a rated current not exceeding 10 A shall be provided with a plug complying with SEV 1011 or IEC 60884-1 and one of the following dimension sheets:

SEV 6532-2.1991	Plug Type 15	3P + N + PE	250/400 V, 10A
SEV 6533-2.1991	Plug Type 11	L + N	250 V, 10A
SEV 6534-2.1991	Plug Type 12	L + N + PE	250 V, 10A

NOTE 16 A plugs do not exist in the Swiss domestic system.

### United Kingdom

Only plugs according to standard sheets B2 and C5 are allowed (see also Annex ZB).

## 25.8

### Ireland and United Kingdom

In Table 11, replace the line for 10 A and 16 A by:

> 10 and ≤ 13	1,25 (1,0) <sup>b</sup>
> 13 and ≤ 16	1,5 (1,0) <sup>b</sup>

**Annex ZB**  
(informative)

**A-deviations**

**A-deviation:** National deviation due to regulations, the alteration of which is at the time being outside the competence of the CEN/CENELEC member.

This European Standard falls under Directive 73/23/EEC.

NOTE (from CEN/CENELEC IR Part 2, 3.1.9): Where standards fall under EC Directives, it is the view of the Commission of the European Communities (OJ No C 59; 1982-03-09) that the effect of the decision of the Court of Justice in case 815/79 Cremonini/Vrankovich (European Court Reports 1980, I, 3583) is that compliance with A-deviations is no longer mandatory and that the free movement of products complying with such a standard should not be restricted except under the safeguard procedure provided for in the relevant Directive.

A-deviations in an EFTA-country are **valid instead** of the relevant provisions of the European Standard in that country until they have been removed.

<u>Clause</u>	<u>Deviation</u>
---------------	------------------

- |          |  |
|----------|--|
| <b>4</b> | <b>Switzerland</b> (Ordinance relating to Environmentally Hazardous Substances, SR 814.013 of 1986-06-09, Annex 4.1) |
|----------|--|

Carbon-zinc batteries shall not be imported as commercial goods or supplied by a manufacturer unless they contain no more cadmium and mercury than is necessary in accordance with the state of the art, but not exceeding a total of 250 mg per kilogram of battery.

Alkali-manganese batteries shall not be imported as commercial goods or supplied by a manufacturer unless they contain no more mercury than is necessary in accordance with the state of the art, but not exceeding 10 g of zinc per kilogram.

- |            |   |
|------------|---|
| <b>7.1</b> | <b>Italy</b> (Statutory Instrument No. 105 of 1949) |
|------------|---|

The voltage is 220 V/380 V.

- |             |   |
|-------------|---|
| <b>25.6</b> | <b>Ireland</b> (Statutory Instrument No. 525 of 1997) |
|-------------|---|

These regulations apply to all plugs for domestic use at a voltage of not less than 200 V and in general allow only plugs complying with I.S. 401:1997, or equivalent, to be fitted to domestic appliances.

**United Kingdom** (Statutory Instrument 1994 No 1768)

These regulations apply to all plugs for domestic use at a voltage of not less than 200 V and in general allow only plugs to BS 1363 to be fitted to domestic appliances. It also allows plugs to BS 4573 and standard sheet C5 to be fitted to shavers and toothbrushes.

- |                 |   |
|-----------------|---|
| <b>A1) 29.3</b> | <b>Germany</b> (Gesetz über technische Arbeitsmittel und Verbraucherschutzprodukte (Geräte- und Produktsicherheitsgesetz,) Article 4, sentence 1 of paragraph 1 [Law on technical labour equipment and consumer products {Equipment and product safety law}] of 6 January 2004. |
|-----------------|---|

The provisions of the third dashed item are not applicable for appliances, where the insulation is accessible. Appropriate additional measures, such as a multi-layered insulation or adequate thickness, shall be taken if used for accessible insulation to ensure that the appliance will not become hazardous in case of the presence of one failure (e.g. a hole in the layer). A1

**Annex ZC**  
(normative)

**Normative references to international publications  
with their corresponding European publications**

The following referenced documents are indispensable for the application of this document. For dated references, only the edition cited applies. For undated references, the latest edition of the referenced document (including any amendments) applies.

NOTE When an international publication has been modified by common modifications, indicated by (mod), the relevant EN/HD applies.

<u>Publication</u>	<u>Year</u>	<u>Title</u>	<u>EN/HD</u>	<u>Year</u>
IEC 60061-1 (mod)	- <sup>1)</sup>	Lamp caps and holders together with gauges for the control of interchangeability and safety Part 1: Lamp caps	EN 60061-1	1993 <sup>2)</sup>
IEC 60068-2-2	- <sup>1)</sup>	Environmental testing Part 2: Tests - Tests B: Dry heat	EN 60068-2-2	1993 <sup>2)</sup>
IEC 60068-2-32	- <sup>1)</sup>	Basic environmental testing procedures Part 2: Tests - Test Ed: Free fall	EN 60068-2-32	1993 <sup>2)</sup>
IEC 60068-2-75	- <sup>1)</sup>	Environmental testing Part 2-75: Tests - Test Eh: Hammer tests	EN 60068-2-75	1997 <sup>2)</sup>
IEC 60083	- <sup>1)</sup>	Plugs and socket-outlets for domestic and similar general use standardized in member countries of IEC	-	-
IEC 60085	2004	Electrical insulation - Thermal classification	EN 60085	2004
IEC 60112	2003	Method for the determination of the proof and the comparative tracking indices of solid insulating materials	EN 60112	2003
IEC 60127	Series	Miniature fuses	EN 60127	Series
IEC 60227 <sup>3)</sup>	Series	Polyvinyl chloride insulated cables of rated voltages up to and including 450/750 V		
IEC 60238	- <sup>1)</sup>	Edison screw lampholders	EN 60238 + corr. January	2004 <sup>2)</sup> 2005
IEC 60245 <sup>4)</sup>	Series	Rubber insulated cables - Rated voltages up to and including 450/750 V		
IEC 60252-1	- <sup>1)</sup>	AC motor capacitors Part 1: General - Performance, testing and rating - Safety requirements - Guide for installation and operation	EN 60252-1	2001 <sup>2)</sup>

1) Undated reference.

2) Valid edition at date of issue.

3) The HD 21 series, which is related to, but not directly equivalent with the IEC 60227 series, applies instead.

4) The HD 22 series, which is related to, but not directly equivalent with the IEC 60245 series, applies instead.

<u>Publication</u>	<u>Year</u>	<u>Title</u>	<u>EN/HD</u>	<u>Year</u>
IEC 60320-1	- <sup>1)</sup>	Appliance couplers for household and similar general purposes Part 1: General requirements	EN 60320-1	2001 <sup>2)</sup>
IEC 60320-2-2	- <sup>1)</sup>	Appliance couplers for household and similar general purposes Part 2-2: Interconnection couplers for household and similar equipment	EN 60320-2-2	1998 <sup>2)</sup>
IEC 60320-2-3	- <sup>1)</sup>	Appliance couplers for household and similar general purposes Part 2-3: Appliance coupler with a degree of protection higher than IPX0	EN 60320-2-3	1998 <sup>2)</sup>
IEC 60384-14	2005	Fixed capacitors for use in electronic equipment Part 14: Sectional specification - Fixed capacitors for electromagnetic interference suppression and connection to the supply mains	EN 60384-14	2005
IEC 60417	Data-base	Graphical symbols for use on equipment	-	-
IEC 60529	- <sup>1)</sup>	Degrees of protection provided by enclosures (IP Code)	EN 60529 + corr. May	1991 <sup>2)</sup> 1993
IEC 60598-1 (mod)	2003	Luminaires Part 1: General requirements and tests	EN 60598-1	2004
IEC 60664-1 (mod) + A1 + A2	1992 2000 2002	Insulation coordination for equipment within low-voltage systems Part 1: Principles, requirements and tests	EN 60664-1	2003
IEC 60664-3	2003	Insulation coordination for equipment within low-voltage systems Part 3: Use of coating, potting or moulding for protection against pollution	EN 60664-3	2003
IEC 60691	2002	Thermal-links - Requirements and application guide	EN 60691	2003
IEC 60695-2-11	- <sup>1)</sup>	Fire hazard testing Part 2-11: Glowing/hot-wire based test methods - Glow-wire flammability test method for end-products	EN 60695-2-11	2001 <sup>2)</sup>
IEC 60695-2-12	- <sup>1)</sup>	Fire hazard testing Part 2-12: Glowing/hot-wire based test methods - Glow-wire flammability test method for materials	EN 60695-2-12	2001 <sup>2)</sup>
IEC 60695-2-13	- <sup>1)</sup>	Fire hazard testing Part 2-13: Glowing/hot-wire based test methods - Glow-wire ignitability test method for materials	EN 60695-2-13	2001 <sup>2)</sup>
IEC 60695-10-2	- <sup>1)</sup>	Fire hazard testing Part 10-2: Abnormal heat - Ball pressure test	EN 60695-10-2	2003 <sup>2)</sup>

<u>Publication</u>	<u>Year</u>	<u>Title</u>	<u>EN/HD</u>	<u>Year</u>
IEC 60695-11-5	2004	Fire hazard testing Part 11-5: Test flames - Needle-flame test method - Apparatus, confirmatory test arrangement and guidance	EN 60695-11-5	2005
IEC 60695-11-10	- <sup>1)</sup>	Fire hazard testing Part 11-10: Test flames - 50 W horizontal and vertical flame test methods	EN 60695-11-10	1999 <sup>2)</sup>
IEC 60730-1 (mod) A1 (mod)	1999 2003	Automatic electrical controls for household and similar use Part 1: General requirements	EN 60730-1 A1 A11 A12 A13 A14 A15	2000 2004 2002 2003 2004 2005 200X <sup>5)</sup>
IEC 60730-2-8 (mod) A1 (mod)	2000 2002	Automatic electrical controls for household and similar use Part 2-8: Particular requirements for electrically operated water valves, including mechanical requirements	EN 60730-2-8 A1	2002 2003
IEC 60738-1	- <sup>1)</sup>	Directly heated positive temperature coefficient thermistors Part 1: Generic specification	EN 60738-1	2006 <sup>2)</sup>
IEC 60906-1	- <sup>1)</sup>	IEC system of plugs and socket-outlets for household and similar purposes Part 1: Plugs and socket-outlets 16 A 250 V a.c.	-	-
IEC 60990	1999	Methods of measurement of touch current and protective conductor current	EN 60990	1999
IEC 60999-1	1999	Connecting devices - Electrical copper conductors - Safety requirements for screw-type and screwless-type clamping units Part 1: General requirements and particular requirements for clamping units for conductors from 0,2 mm <sup>2</sup> up to 35 mm <sup>2</sup> (included)	EN 60999-1	2000
IEC 61000-4-2	- <sup>1)</sup>	Electromagnetic compatibility (EMC) Part 4-2: Testing and measurement techniques - Electrostatic discharge immunity test	EN 61000-4-2	1995 <sup>2)</sup>
IEC 61000-4-3	- <sup>1)</sup>	Electromagnetic compatibility (EMC) Part 4-3 : Testing and measurement techniques - Radiated, radio-frequency, electromagnetic field immunity test	EN 61000-4-3	2006 <sup>2)</sup>
IEC 61000-4-4	- <sup>1)</sup>	Electromagnetic compatibility (EMC) Part 4-4: Testing and measurement techniques - Electrical fast transient/burst immunity test	EN 61000-4-4	2004 <sup>2)</sup>

---

5) To be published

**BS EN 60335-1:2002+A2:2006**

<u>Publication</u>	<u>Year</u>	<u>Title</u>	<u>EN/HD</u>	<u>Year</u>
IEC 61000-4-5	- <sup>1)</sup>	Electromagnetic compatibility (EMC) Part 4-5: Testing and measurement techniques - Surge immunity test	EN 61000-4-5	200X <sup>6)</sup>
IEC 61000-4-6	- <sup>1)</sup>	Electromagnetic compatibility (EMC) Part 4-6: Testing and measurement techniques - Immunity to conducted disturbances, induced by radio-frequency fields	EN 61000-4-6	1996 <sup>2)</sup>
IEC 61000-4-11	2004	Electromagnetic compatibility (EMC) Part 4-11: Testing and measurement techniques - Voltage dips, short interruptions and voltage variations immunity tests	EN 61000-4-11	2004
IEC 61000-4-13	- <sup>1)</sup>	Electromagnetic compatibility (EMC) Part 4-13: Testing and measurement techniques - Harmonics and interharmonics including mains signalling at a.c. power port, low frequency immunity tests	EN 61000-4-13	2002 <sup>2)</sup>
IEC 61032	1997	Protection of persons and equipment by enclosures - Probes for verification	EN 61032	1998
IEC 61058-1 (mod) + A1	2000 2001	Switches for appliances Part 1: General requirements	EN 61058-1	2002
IEC 61180-1	- <sup>1)</sup>	High-voltage test techniques for low-voltage equipment Part 1: Definitions, test and procedure requirements	EN 61180-1	1994 <sup>2)</sup>
IEC 61180-2	- <sup>1)</sup>	High-voltage test techniques for low-voltage equipment Part 2: Test equipment	EN 61180-2	1994 <sup>2)</sup>
IEC 61558-1 (mod) A1	1997 1998	Safety of power transformers, power supply units and similar Part 1: General requirements and tests	EN 61558-1 <sup>7)</sup> + corr. April A1 A11	1997 2003 1998 2003
IEC 61558-2-6	1997	Safety of power transformers, power supply units and similar Part 2-6: Particular requirements for safety isolating transformers for general use	EN 61558-2-6	1997
IEC 61770	- <sup>1)</sup>	Electric appliances connected to the water mains - Avoidance of backsiphonage and failure of hose-sets	EN 61770	1999 <sup>2)</sup>
IEC 62151	2000	Safety of equipment electrically connected to a telecommunication network	-	-

6) To be ratified.

7) EN 61558-1 is superseded by EN 61558-1:2005, which is based on IEC 61558-1:2005.



<u>Publication</u>	<u>Year</u>	<u>Title</u>	<u>EN/HD</u>	<u>Year</u>
ISO 2768-1	- <sup>1)</sup>	General tolerances Part 1: Tolerances for linear and angular dimensions without individual tolerance indications	EN 22768-1	1993
ISO 7000	Data- base	Graphical symbols for use on equipment - Index and synopsis		-
ISO 9772 A1	2001 2003	Cellular plastics - Determination of horizontal burning characteristics of small specimens subjected to a small flame	-	-
			-	-

<http://www.china-gauges.com/>

**Annex ZD**  
(informative)

**IEC and CENELEC code designations for flexible cords**

Type of flexible cord	Code designations	
	IEC	CENELEC
<i>PVC insulated cords</i>		
Flat twin tinsel cord	60227 IEC 41	H03VH-Y
Light polyvinyl chloride sheathed flexible cord	60227 IEC 52	H03VV-F H03VVH2-F
Ordinary polyvinyl chloride sheathed flexible cord	60227 IEC 53	H05VV-F H05VVH2-F
<i>Rubber insulated cords</i>		
Braided cord	60245 IEC 51	H03RT-F
Ordinary tough rubber sheathed flexible cord	60245 IEC 53	H05RR-F
Ordinary polychloroprene sheathed flexible cord	60245 IEC 57	H05RN-F
Heavy polychloroprene sheathed flexible cord	60245 IEC 66	H07RN-F
<i>Cords having high flexibility</i>		
Rubber insulated and sheathed cord	60245 IEC 86	H03RR-H
Rubber insulated, crosslinked PVC sheathed cord	60245 IEC 87	H03RV4-H
Crosslinked PVC insulated and sheathed cord	60245 IEC 88	H03V4V4-H

## Bibliography

- A1** IEC 60034-1, *Rotating electrical machines – Part 1: Rating and performance* **A1**
- A1** IEC 60065, *Audio, video and similar electronic apparatus – Safety requirements* **A1**
- IEC 60335-2-29, *Safety of household and similar electrical appliances – Part 2-29: Particular requirements for battery chargers*
- IEC 60364 (all parts), *Electrical installations of buildings*
- IEC 60601 (all parts), *Medical electrical equipment*
- A2** IEC 60695-4, *Fire hazard testing – Part 4: Terminology concerning fire tests for electro-technical products* **A2**
- A1** IEC 60721-2-1, *Classification of environmental conditions – Part 2: Environmental conditions appearing in nature – Temperature and humidity* **A1**
- A1** IEC 60730-2-10, *Automatic electrical controls for household and similar use – Part 2: Particular requirements for electrically operated motor starting relays* **A1**
- C11** IEC 60745 (all parts), *Safety of hand-held motor-operated electric tools* **C11**
- IEC 60950, *Safety of information technology equipment*
- A1** IEC 60998-2-1, *Connecting devices for low voltage circuits for household and similar purposes – Part 2-1: Particular requirements for connecting devices as separate entities with screw-type clamping units* **A1**
- A1** IEC 60998-2-2, *Connecting devices for low voltage circuits for household and similar purposes – Part 2-2: Particular requirements for connecting devices as separate entities with screwless-type clamping units* **A1**
- IEC 61000-3-2, *Electromagnetic compatibility (EMC) – Part 3-2: Limits – Limits for harmonic current emissions (equipment input current  $\leq 16$  A per phase)*
- IEC 61000-3-3, *Electromagnetic compatibility (EMC) – Part 3: Limits – Section 3: Limitation of voltage fluctuations and flicker in low voltage supply systems for equipment with rated current  $\leq 16$  A*
- C11** IEC 61029, (all parts), *Safety of transportable motor-operated electric tools* **C11**
- A1** IEC 61643-1, *Surge protective devices connected to low-voltage power distribution systems – Part 1: Performance requirements and testing methods.* **A1**
- CISPR 11, *Industrial, scientific and medical (ISM) radio frequency equipment – Electromagnetic disturbance characteristics – Limits and methods of measurement*
- CISPR 14-1, *Electromagnetic compatibility – Requirements for household appliances, electric tools and similar apparatus – Part 1: Emission*

CISPR 14-2, *Electromagnetic compatibility – Requirements for household appliances, electric tools and similar apparatus – Part 2: Immunity – Product family standard*

☐<sub>A1</sub> ISO 1463, *Metallic and oxide coatings – Measurement of coating thickness – Microscopical method*

ISO 2178, *Non-magnetic coatings on magnetic substrates – Measurement of coating thickness – Magnetic method*

IEC Guide 104, *The preparation of safety publications and the use of basic safety publications and group safety publications*

IEC Guide 110, *Home control systems – Guidelines relating to safety*

ISO/IEC Guide 14, *Product information for consumers*

ISO/IEC Guide 37, *Instructions for use of products of consumer interest*

ISO/IEC Guide 50, *Safety aspects – Guidelines for child safety*

ISO/IEC Guide 51, *Safety aspects – Guidelines for their inclusion in standards*

ISO/IEC Guide 71, *Guidelines for standards developers to address the needs of older persons and persons with disabilities* ☐<sub>A1</sub>

### **A1** Index of defined words

accessible part.....	3.6.3	PTC heating element.....	3.8.4
all-pole disconnection.....	3.8.1	portable appliance .....	3.5.1
basic insulation.....	3.3.1	protective device.....	3.7.6
built-in appliance.....	3.5.5	protective electronic circuit.....	3.9.3
class 0 appliance.....	3.3.7	protective extra-low voltage circuit .....	3.4.4
class 0I appliance.....	3.3.8	protective impedance.....	3.3.6
class I appliance.....	3.3.9	rated current .....	3.1.6
class II appliance.....	3.3.10	rated frequency .....	3.1.7
class III appliance.....	3.3.12	rated frequency range.....	3.1.8
class II construction.....	3.3.11	rated impulse voltage .....	3.1.10
class III construction.....	3.3.13	rated power input.....	3.1.4
clearance .....	3.3.14	rated power input range .....	3.1.5
combined appliance .....	3.5.8	rated voltage .....	3.1.1
creepage distance.....	3.3.15	rated voltage range .....	3.1.2
dangerous malfunction.....	3.1.11	reinforced insulation.....	3.3.4
detachable cord.....	3.2.1	safety extra-low voltage .....	3.4.2
detachable part.....	3.6.2	safety isolating transformer.....	3.4.3
double insulation.....	3.3.3	self-resetting thermal cut-out.....	3.7.4
electronic circuit.....	3.9.2	software class B.....	3.9.4
electronic component.....	3.9.1	software class C.....	3.9.5
extra-low voltage.....	3.4.1	stationary appliance .....	3.5.3
fixed appliance .....	3.5.4	supplementary insulation.....	3.3.2
functional insulation .....	3.3.5	supply cord.....	3.2.3
hand-held appliance.....	3.5.2	supply leads .....	3.2.7
heating appliance.....	3.5.6	temperature limiter.....	3.7.2
interconnection cord.....	3.2.2	thermal cut-out .....	3.7.3
live part.....	3.6.4	thermal link.....	3.7.7
motor-operated appliance.....	3.5.7	thermostat .....	3.7.1
non-detachable part.....	3.6.1	tool .....	3.6.5
non-self-resetting thermal cut-out .....	3.7.5	type X attachment.....	3.2.4
normal operation.....	3.1.9	type Y attachment.....	3.2.5
off position .....	3.8.2	type Z attachment.....	3.2.6
		user maintenance .....	3.8.5
		visibly glowing heating element .....	3.8.3
		working voltage .....	3.1.3 <b>A1</b>

**National Annex NA**  
(informative)

**Original IEC text amended by CENELEC common modifications**

The text of the International Standard IEC 60335-1:2001, excluding the corrigendum January 2002, was approved by CENELEC as a European Standard with agreed common modifications as given below.

COMMON MODIFICATIONS

**Introduction**

Add:

The principal objectives of the Low Voltage Directive, 73/23/EEC, are covered by this standard. The essential safety requirements of the following directives, which can be applicable to some household and similar appliances, have also been taken into account:

- 98/37/EC – Machinery directive;
- 89/106/EEC – Construction products directive;
- 97/23/EC – Pressure equipment directive.

**6 Classification**

6.1 Delete “class 0” and “class 0I”.

**7 Marking and instructions**

7.1 Add:

The marking of **rated voltage** or **rated voltage range**, for appliances intended to be connected to the supply mains, shall cover:

- 230 V for single-phase appliances;
- 400 V for multi-phase appliances.

**25 Supply connection and external flexible cords**

25.6 Add:

**Supply cords** of single-phase **portable appliances** having a **rated current** not exceeding 16 A shall be fitted with a plug complying with the following standard sheets of IEC 60083:1975:

- for **class I appliances** standard sheet C2b, C3b or C4;
- for **class II appliances** standard sheet C5 or C6.

25.7 Add after the second dashed item:

- ordinary polychloroprene sheathed flexible cord (code designation 60245 IEC 57).

Add before the note:

When **supply cords** having high flexibility are used, they shall not be lighter than

- rubber insulated and sheathed cord (code designation 60245 IEC 86);
- rubber insulated, crosslinked PVC sheathed cord (code designation 60245 IEC 87);
- crosslinked PVC insulated and sheathed cord (code designation 60245 IEC 88).

Add after the note:

NOTE Z1 The harmonized code designations corresponding to the IEC cord types are given in Annex ZD.

## National Annex NB (informative)

### IEC Interpretation Sheet February 2007

This National Annex NB reproduces IEC Interpretation Sheet February 2007.

TC 61/Publication 60335-1 (2001) Amendment 1, Fourth edition/I-SH 01

#### HOUSEHOLD AND SIMILAR ELECTRICAL APPLIANCES – SAFETY – Part 1: General requirements

#### INTERPRETATION SHEET

This interpretation sheet has been prepared by technical committee 61: Safety of household and similar electrical appliances.

The text of this interpretation sheet is based on the following documents:

ISH	Report on voting
61/3142/ISH	61/3219/RVD

Full information on the voting for the approval of this interpretation sheet can be found in the report on voting indicated in the above table.

#### Subclause 22.46

*This subclause introduced by amendment 1 is clarified by following:*

Software used in **protective electronic circuits** shall be **software class B** or **software class C**.

If failure of the software in the presence of another fault in the appliance would result in a hazard, then **software class B** shall be used. If failure of software alone would result in a hazard, then **software class C** shall be used.

*Compliance is checked by evaluating the software in accordance with the relevant requirements of Annex R and, for checking if the correct software class is used, by assessing whether failure of the function controlled by the software can result in a **dangerous malfunction**, electric shock, fire, mechanical or other hazard.*

NOTE 1 Software class A denotes software used for functional purposes.

NOTE 2 In case the software is modified, the evaluation and relevant tests are repeated if the modification can influence the results of the tests involving **protective electronic circuits**.



<http://www.china-gauges.com/>

---

---

## BSI — British Standards Institution

BSI is the independent national body responsible for preparing British Standards. It presents the UK view on standards in Europe and at the international level. It is incorporated by Royal Charter.

### Revisions

British Standards are updated by amendment or revision. Users of British Standards should make sure that they possess the latest amendments or editions.

It is the constant aim of BSI to improve the quality of our products and services. We would be grateful if anyone finding an inaccuracy or ambiguity while using this British Standard would inform the Secretary of the technical committee responsible, the identity of which can be found on the inside front cover. Tel: +44 (0)20 8996 9000. Fax: +44 (0)20 8996 7400.

BSI offers members an individual updating service called PLUS which ensures that subscribers automatically receive the latest editions of standards.

### Buying standards

Orders for all BSI, international and foreign standards publications should be addressed to Customer Services. Tel: +44 (0)20 8996 9001. Fax: +44 (0)20 8996 7001. Email: [orders@bsi-global.com](mailto:orders@bsi-global.com). Standards are also available from the BSI website at <http://www.bsi-global.com>.

In response to orders for international standards, it is BSI policy to supply the BSI implementation of those that have been published as British Standards, unless otherwise requested.

### Information on standards

BSI provides a wide range of information on national, European and international standards through its Library and its Technical Help to Exporters Service. Various BSI electronic information services are also available which give details on all its products and services. Contact the Information Centre. Tel: +44 (0)20 8996 7111. Fax: +44 (0)20 8996 7048. Email: [info@bsi-global.com](mailto:info@bsi-global.com).

Subscribing members of BSI are kept up to date with standards developments and receive substantial discounts on the purchase price of standards. For details of these and other benefits contact Membership Administration. Tel: +44 (0)20 8996 7002. Fax: +44 (0)20 8996 7001. Email: [membership@bsi-global.com](mailto:membership@bsi-global.com).

Information regarding online access to British Standards via British Standards Online can be found at <http://www.bsi-global.com/bsonline>.

Further information about BSI is available on the BSI website at <http://www.bsi-global.com>.

### Copyright

Copyright subsists in all BSI publications. BSI also holds the copyright, in the UK, of the publications of the international standardization bodies. Except as permitted under the Copyright, Designs and Patents Act 1988 no extract may be reproduced, stored in a retrieval system or transmitted in any form or by any means – electronic, photocopying, recording or otherwise – without prior written permission from BSI.

This does not preclude the free use, in the course of implementing the standard, of necessary details such as symbols, and size, type or grade designations. If these details are to be used for any other purpose than implementation then the prior written permission of BSI must be obtained.

Details and advice can be obtained from the Copyright & Licensing Manager. Tel: +44 (0)20 8996 7070. Fax: +44 (0)20 8996 7553. Email: [copyright@bsi-global.com](mailto:copyright@bsi-global.com).