

EUROPEAN STANDARD

EN 60745-2-5

NORME EUROPÉENNE

EUROPÄISCHE NORM

June 2003

ICS 25.100.40

Supersedes EN 50144-2-5:1999 & EN 50260-2-5:2002

English version

**Hand-held motor-operated electric tools -
Safety**
Part 2-5: Particular requirements for circular saws
(IEC 60745-2-5:2003, modified)

Outils électroportatifs à moteur -
Sécurité
Partie 2-5: Règles particulières
pour les scies circulaires
(CEI 60745-2-5:2003, modifiée)

Handgeführte motorbetriebene
Elektrowerkzeuge -
Sicherheit
Teil 2-5: Besondere Anforderungen
für Kreissägen
(IEC 60745-2-5:2003, modifiziert)

This European Standard was approved by CENELEC on 2003-04-01. CENELEC members are bound to comply with the CEN/CENELEC Internal Regulations which stipulate the conditions for giving this European Standard the status of a national standard without any alteration.

Up-to-date lists and bibliographical references concerning such national standards may be obtained on application to the Central Secretariat or to any CENELEC member.

This European Standard exists in three official versions (English, French, German). A version in any other language made by translation under the responsibility of a CENELEC member into its own language and notified to the Central Secretariat has the same status as the official versions.

CENELEC members are the national electrotechnical committees of Austria, Belgium, Czech Republic, Denmark, Finland, France, Germany, Greece, Hungary, Iceland, Ireland, Italy, Luxembourg, Malta, Netherlands, Norway, Portugal, Slovakia, Spain, Sweden, Switzerland and United Kingdom.

CENELEC

European Committee for Electrotechnical Standardization
Comité Européen de Normalisation Electrotechnique
Europäisches Komitee für Elektrotechnische Normung

Central Secretariat: rue de Stassart 35, B - 1050 Brussels

© 2003 CENELEC - All rights of exploitation in any form and by any means reserved worldwide for CENELEC members.

Ref. No. EN 60745-2-5:2003 E

Foreword

The text of the International Standard IEC 60745-2-5:2003, prepared by SC 61F, Safety of hand-held motor-operated electric tools, of IEC TC 61, Safety of household and similar electrical appliances, together with the common modifications prepared by the Technical Committee CENELEC TC 61F, Safety of hand-held and transportable motor operated electric tools, was submitted to the formal vote and was approved by CENELEC as EN 60745-2-5 on 2003-04-01.

This European Standard supersedes EN 50144-2-5:1999 and EN 50260-2-5:2002.

The following dates were fixed:

- latest date by which the EN has to be implemented at national level by publication of an identical national standard or by endorsement (dop) 2004-04-01
- latest date by which the national standards conflicting with the EN have to be withdrawn (dow) 2006-04-01

Other standards referred to in this European standard are listed in Clause 2. Clause 2 lists the valid edition of those documents at the time of issue of this EN.

This standard is divided into two parts:

Part 1: General requirements which are common to most hand-held electric motor operated tools (for the purpose of this standard referred to simply as tools) which could come within the scope of this standard;

Part 2: Requirements for particular types of tools which either supplement or modify the requirements given in Part 1 to account for the particular hazards and characteristics of these specific tools.

This European Standard has been prepared under a mandate given to CEN and CENELEC by the European Commission and the European Free Trade Association and supports the essential health and safety requirements of the Machinery Directive.

Compliance with the clauses of Part 1 together with this Part 2-5 provides one means of conforming with the essential health and safety requirements of the Directive concerned.

CEN/TC 255 is producing standards for non-electric circular saws (EN 792-12).

Warning: Other requirements and other EC Directives can be applicable to the products falling within the scope of this standard.

This standard follows the overall requirements of EN 292-1 and EN 292-2.

This Part 2-5 is to be used in conjunction with EN 60745-1:2003. When this standard states "addition", "modification" or "replacement", the relevant text in Part 1 is to be adapted accordingly.

Subclauses and figures which are additional to those in Part 1 are numbered starting from 101; additional annexes are lettered AA, BB, etc.

Subclauses, tables and figures which are additional to those in IEC 60745-2-5 are prefixed "Z".

NOTE In this standard, the following print types are used:

- Requirements: in roman type;
- *Test specification: in italic type;*
- Notes: in smaller roman type.

Endorsement notice

The text of the International Standard IEC 60745-2-5:2003 was approved by CENELEC as a European Standard with agreed common modifications as given below.

.....

CONTENTS

1	Scope	5
2	Normative references	5
3	Definitions	5
4	General requirements	6
5	General conditions for the tests	6
6	Void	6
7	Classification	7
8	Marking and instructions	7
9	Protection against access to live parts	10
10	Starting	10
11	Input and current	10
12	Heating	10
13	Leakage current	10
14	Moisture resistance	10
15	Electric strength	10
16	Overload protection of transformers and associated circuits	10
17	Endurance	10
18	Abnormal operation	11
19	Mechanical hazards	11
20	Mechanical strength	15
21	Construction	16
22	Internal wiring	16
23	Components	16
24	Supply connection and external flexible cords	16
25	Terminals for external conductors	16
26	Provision for earthing	16
27	Screws and connections	16
28	Creepage distances, clearances and distances through insulation	17
29	Resistance to heat, fire and tracking	17
30	Resistance to rusting	17
31	Radiation, toxicity and similar hazards	17
	Annexes	26
	Annex AA (normative) Additional requirements for saws with a riving knife	26
	Annex BB (normative) Additional requirements for lower guards for saws without a riving knife	29
	Bibliography	30

HAND-HELD MOTOR-OPERATED ELECTRIC TOOLS – SAFETY –

Part 2-5: Particular requirements for circular saws

1 Scope

This clause of Part 1 is applicable, except as follows:

1.1 Addition:

This standard applies to all types of circular saws. Circular saws hereinafter will be referred to as saws. This standard does not apply to saws used with abrasive wheels.

2 Normative references

☐ This clause of Part 1 is applicable, except as follows:

EN 847-1:1997, *Tools for woodworking — Safety requirements — Part 1: Milling tools and circular saw blades* ☐

3 Definitions

This clause of Part 1 is applicable, except as follows:

Additional definitions:

3.101

circular saw

tool intended for cutting various materials with a rotating toothed blade

3.102

cutting edge zone

the outer 20 % of the blade's radius

3.103

guide plate

the part of the saw resting on the material to be cut (see Figure 113)

3.104

lower guard

movable blade-covering device which, in the closed or rest position, is generally situated below the guide plate

3.105

upper guard

fixed and/or movable cover of the blade situated above the guide plate

3.106

riving knife

metal part placed in the plane of the saw blade with the intent of preventing the workpiece from closing on the rear part of the saw blade

3.107

saw with outer pendulum guard

saw having a lower guard which swings outside the upper guard (see Figure 101)

3.108

saw with inner pendulum guard

saw having a lower guard which swings inside the upper guard (see Figure 102)

3.109

saw with tow guard

saw having a lower guard which slides along the upper guard (see Figure 103)

3.110

kickback

sudden reaction to a pinched, bound or misaligned saw blade, causing an uncontrolled saw to lift up and out of the workpiece

3.111

plunge type saw

saw having only an upper guard into which the saw blade retracts when not in use (see Figure 104)

4 General requirements

This clause of Part 1 is applicable.

5 General conditions for the tests

This clause of Part 1 is applicable.

6  Environmental requirements

This clause of Part 1 is applicable except as follows:

6.1.2.4 Modification:

Circular saws are held and used as specified in 6.1.2.5.

6.1.2.5 Modification:

Circular saws are tested under load observing the conditions shown in Table Z101. 

Ⓒ

Table Z101 — Operating conditions for circular saws

Orientation	Cutting a horizontal piece of chipboard 800 mm × 400 mm × 19 mm. The workpiece, apart from the strips to be cut off, is supported on resilient material and fixed to a bench
Tool bit	New blade as recommended by the manufacturer for cutting chipboard
Feed force	Just sufficient to cut at a brisk pace
Test cycle	One test cycle is given by cutting off one approximately 10 mm wide strip (set by rip fence) across the 400 mm width of the chipboard

6.2.2.4 Modification:

Circular saws are tested under the conditions specified in 6.1.2.5. Ⓒ

7 Classification

This clause of Part 1 is applicable.

8 Marking and instructions

This clause of Part 1 is applicable, except as follows:

8.1 Addition:

Saws shall be marked with:

- direction of rotation, indicated on the tool by an arrow, raised or recessed or by any other means no less visible and indelible;
- rated no-load speed of the output spindle;
- recommended blade diameter.

8.12.2 a) Addition:

101) Instructions not to use any abrasive wheels

102) For saws with riving knife the instruction shall include the following:

Instructions to ensure that the riving knife is adjusted so that the distance between the riving knife and the rim of the blade is not more than 5 mm, and the rim of the blade does not extend more than 5 mm beyond the lowest edge of the riving knife.

Ⓒ

Z101) Information on the correct use of the dust collection system

Z102) Advice to wear a dust mask

Z103) Instruction to only use saw blades recommended

Z104) Instruction to always wear hearing protection Ⓒ

8.12.2 b) Addition

101) Instructions for the blade changing procedure

Additional subclause:

8.12.101 The following additional safety instructions shall be given. If in English they shall be verbatim and in the following order as applicable and equivalent in any other language. This part may be printed separately from the General Safety Instructions. All notes are not to be printed, they are information for the designer of the manual.

8.12.101.1 Safety instructions for all saws

DANGER:

a) **Keep hands away from cutting area and the blade. Keep your second hand on auxiliary handle, or motor housing. If both hands are holding the saw, they cannot be cut by the blade.**

NOTE For circular saws with 140 mm or smaller diameter blades, the "Keep your second hand on auxiliary handle, or motor housing" may be omitted.

b) **Do not reach underneath the workpiece. The guard cannot protect you from the blade below the workpiece.**

c) **Adjust the cutting depth to the thickness of the workpiece. Less than a full tooth of the blade teeth should be visible below the workpiece.**

d) **Never hold piece being cut in your hands or across your leg. Secure the workpiece to a stable platform. It is important to support the work properly to minimize body exposure, blade binding, or loss of control.**

e) **Hold power tool by insulated gripping surfaces when performing an operation where the cutting tool may contact hidden wiring or its own cord. Contact with a "live" wire will also make exposed metal parts of the power tool "live" and shock the operator.**

f) **When ripping always use a rip fence or straight edge guide. This improves the accuracy of cut and reduces the chance of blade binding.**

g) **Always use blades with correct size and shape (diamond versus round) of arbour holes. Blades that do not match the mounting hardware of the saw will run eccentrically, causing loss of control.**

h) **Never use damaged or incorrect blade washers or bolt. The blade washers and bolt were specially designed for your saw, for optimum performance and safety of operation.**

8.12.101.2 Further safety instructions for all saws

Causes and operator prevention of kickback:

- kickback is a sudden reaction to a pinched, bound or misaligned saw blade, causing an uncontrolled saw to lift up and out of the workpiece toward the operator;
- when the blade is pinched or bound tightly by the kerf closing down, the blade stalls and the motor reaction drives the unit rapidly back toward the operator;
- if the blade becomes twisted or misaligned in the cut, the teeth at the back edge of the blade can dig into the top surface of the wood causing the blade to climb out of the kerf and jump back toward the operator.

Kickback is the result of saw misuse and/or incorrect operating procedures or conditions and can be avoided by taking proper precautions as given below.

a) **Maintain a firm grip with both hands on the saw and position your arms to resist kickback forces. Position your body to either side of the blade, but not in line with the blade. Kickback could cause the saw to jump backwards, but kickback forces can be controlled by the operator, if proper precautions are taken.**

NOTE For circular saws with 140 mm or smaller diameter blades, the words "with both hands" may be omitted.

- b) **When blade is binding, or when interrupting a cut for any reason, release the trigger and hold the saw motionless in the material until the blade comes to a complete stop. Never attempt to remove the saw from the work or pull the saw backward while the blade is in motion or kickback may occur. Investigate and take corrective actions to eliminate the cause of blade binding.**
- c) **When restarting a saw in the workpiece, centre the saw blade in the kerf and check that saw teeth are not engaged into the material. If saw blade is binding, it may walk up or kickback from the workpiece as the saw is restarted.**
- d) **Support large panels to minimise the risk of blade pinching and kickback. Large panels tend to sag under their own weight. Supports must be placed under the panel on both sides, near the line of cut and near the edge of the panel.**
- e) **Do not use dull or damaged blades. Unsharpened or improperly set blades produce narrow kerf causing excessive friction, blade binding and kickback.**
- f) **Blade depth and bevel adjusting locking levers must be tight and secure before making cut. If blade adjustment shifts while cutting, it may cause binding and kickback.**
- g) **Use extra caution when making a "plunge cut" into existing walls or other blind areas. The protruding blade may cut objects that can cause kickback.**

8.12.101.3 Safety instructions for saws shown in Figures 101, 102 and 103

- a) **Check lower guard for proper closing before each use. Do not operate the saw if lower guard does not move freely and close instantly. Never clamp or tie the lower guard into the open position. If saw is accidentally dropped, lower guard may be bent. Raise the lower guard with the retracting handle and make sure it moves freely and does not touch the blade or any other part, in all angles and depths of cut.**

NOTE Alternate wording may be substituted for "retracting handle."

- b) **Check the operation of the lower guard spring. If the guard and the spring are not operating properly, they must be serviced before use. Lower guard may operate sluggishly due to damaged parts, gummy deposits, or a build-up of debris.**
- c) **Lower guard should be retracted manually only for special cuts such as "plunge cuts" and "compound cuts." Raise lower guard by retracting handle and as soon as blade enters the material, the lower guard must be released. For all other sawing, the lower guard should operate automatically.**

NOTE Alternate wording may be substituted for "retracting handle."

- d) **Always observe that the lower guard is covering the blade before placing saw down on bench or floor. An unprotected, coasting blade will cause the saw to walk backwards, cutting whatever is in its path. Be aware of the time it takes for the blade to stop after switch is released.**

8.12.101.4 Safety instructions for saws shown in Figure 104

- a) **Check guard for proper closing before each use. Do not operate the saw if guard does not move freely and enclose the blade instantly. Never clamp or tie the guard with the blade exposed. If saw is accidentally dropped, guard may be bent. Check to make sure that guard moves freely and does not touch the blade or any other part, in all angles and depths of cut.**
- b) **Check the operation and condition of the guard return spring. If the guard and the spring are not operating properly, they must be serviced before use. Guard may operate sluggishly due to damaged parts, gummy deposits, or a build-up of debris.**
- c) **Assure that the guide plate of the saw will not shift while performing the "plunge cut" when the blade bevel setting is not at 90°. Blade shifting sideways will cause binding and likely kick back.**
- d) **Always observe that the guard is covering the blade before placing saw down on bench or floor. An unprotected, coasting blade will cause the saw to walk backwards, cutting whatever is in its path. Be aware of the time it takes for the blade to stop after switch is released.**

8.12.101.5 Additional safety instructions for all saws with riving knife

- a) **Use the appropriate riving knife for the blade being used.** *For the riving knife to work, it must be thicker than the body of the blade but thinner than the tooth set of the blade.*
- b) **Adjust the riving knife as described in this instruction manual.** *Incorrect spacing, positioning and alignment can make the riving knife ineffective in preventing kickback.*
- c) **Always use the riving knife except when plunge cutting.** *Riving knife must be replaced after plunge cutting. Riving knife causes interference during plunge cutting and can create kickback.*
- d) **For the riving knife to work, it must be engaged in the workpiece.** *The riving knife is ineffective in preventing kickback during short cuts.*
- e) **Do not operate the saw if riving knife is bent.** *Even a light interference can slow the closing rate of a guard.*

9 Protection against access to live parts

This clause of Part 1 is applicable.

10 Starting

This clause of Part 1 is applicable.

11 Input and current

This clause of Part 1 is applicable.

12 Heating

This clause of Part 1 is applicable.

13 Leakage current

This clause of Part 1 is applicable.

14 Moisture resistance

This clause of Part 1 is applicable.

15 Electric strength

This clause of Part 1 is applicable.

16 Overload protection of transformers and associated circuits

This clause of Part 1 is applicable.

17 Endurance

This clause of Part 1 is applicable.

18 Abnormal operation

This clause of Part 1 is applicable.

19 Mechanical hazards

This clause of Part 1 is applicable, except as follows:

19.1 Replacement:

Saws shall be so guarded as to minimise the risk of accidental access to the rotating blade as far as conditions of use will permit. Guarding systems shall not be removable without the aid of a tool.

There are four commonly used guarding systems for saws, as shown in Figures 101, 102, 103 and 104. Guarding systems can be designed with the blade on the right or on the left side of the saw. These guarding systems shall comply with the requirements of 19.101 and 19.102. Each one of these guarding system types can be designed with or without the riving knife (item 6 in the figures).

- If a guarding system is designed with a riving knife, it shall meet the additional requirements of Annex AA.
- If a guarding system is designed without a riving knife, it shall meet the additional requirements of Annex BB.

Other means of achieving the necessary degree of mechanical safety are allowed, provided that these are as equally effective and reliable as those specified.

Compliance is checked by inspection.

Additional subclauses:

19.101 Guarding above the guide plate

19.101.1 The blade above the guide plate shall be guarded by the upper guard.

19.101.2 Apertures in the guarding system above the guide plate, unless otherwise specified below, shall be designed such that the test probe 'a' of Figure 105, when inserted at any angle and to the depth allowed by its stop, shall not be able to contact the cutting edge zone of any recommended blade.

19.101.2.1 On the motor side of the upper guard, adjacent to the cutting edge zone at the front of the blade an aperture may be provided for viewing the line of the cut. This viewing aperture shall either meet the requirements of 19.101.2, as illustrated in Figure 106, or it shall be limited by proximity and height restrictions.

- Proximity restriction

The straight line distance from a defined measuring point on the auxiliary handle surface to the cutting edge zone of any recommended blade shall be a minimum of 120 mm as shown in Figure 107. If there is no auxiliary handle provided, the distance shall be measured from the motor casing.

Compliance is checked by the following measurements, which shall be conducted with the guide plate set to maximum depth of cut and 90°.

To establish the measuring point on the auxiliary handle or the motor casing, follow the procedure outlined below.

- a) Establish the closest (A) and the most distant (B) points on the auxiliary handle or motor casing from the blade. For the motor casing, the closest (A) point to the blade is assumed to be in the plane of the main handle farthest from the blade. Equidistant between points (A) and (B), but not more than 45 mm away from point (A), draw the vertical intersecting line of the plane parallel with the blade and the surface of the auxiliary handle or motor casing, as applicable.
 - b) Establish the closest (C) and the most distant (D) point from the plane of the guide plate on the auxiliary handle or motor casing. Equidistant between points (C) and (D), draw the horizontal intersecting line of the plane parallel with the guide plate and the surface of the auxiliary handle or motor casing, as applicable.
 - c) The intersection of the vertical and horizontal lines drawn on the applicable surface is the defined measuring point.
- Height restriction

The height of the viewing aperture (H) above the guide plate, as shown in Figure 108a, is limited to the point where the line of sight, from the ordinary operator's head position to the tip of the saw blade cutting the wood, is intersecting the outer surface of the upper guard.

The maximum permissible height H , in millimetres, is given by the formula

$$H = \frac{848 U}{205 + S}$$

where

- U is the maximum distance, in millimetres, from the cutting edge zone to the outer surface of the upper guard at the top end of the viewing aperture, measured perpendicularly to the plane of the saw blade (see Figure 108b);
- S is the distance, in millimetres, from the plane of the saw blade to a parallel centerplane of the switch handle (see Figure 108c).

Compliance is checked by measurement.

19.101.2.2 The upper guard on the side opposite the motor need not completely cover the blade. The perpendicular projection of the upper guard on to the blade shall cover at least the smallest recommended blade-cutting edge zone. The space between the upper guard and the blade shall be designed such that the test probe 'a' of Figure 105 when inserted at any angle and to the depth allowed by its stop, shall not be able to contact the saw blade teeth tips of the recommended blade, as illustrated in Figure 106.

19.101.2.3 For saws having an inclinable guide plate, the distance between the guide plate and the upper guard on the side opposite to the motor and adjacent to the front cutting edge zone of the blade shall not exceed the parameters given below.

Compliance is checked by inspection.

When the guide plate is set for maximum depth of cut at the 90° setting, the maximum distance shall not exceed 38 mm, measured from the lateral side of the upper guard to the nearest edge of the guide plate below the upper guard and adjacent to the cutting zone, as shown in Figure 109.

19.101.2.4 For checking the accessibility of the cutting edge zone at the front of the saw above the guide plate, the rigid test probe 'b' of Figure 110 shall not contact the blade when the saw is set for a 90° cut and maximum depth of cut and the probe 'b' is centred with the blade then advanced in any single plane perpendicular to the blade and parallel to the guide plate, as specified in Figure 111. The test is repeated with probe 'b' offset 13 mm to the right of the blade centre and then offset 13 mm to the left of the blade centre.

Compliance is checked by inspection and measurements.

19.101.3 Plunge type saws (see Figure 104) shall be equipped with an upper guard into which any recommended blade shall automatically retract when not in use. The opening in the upper guard for the passage of the blade and riving knife, if any, shall comply with 19.101.2, as illustrated in Figure 106. The upper guard shall lock the blade automatically in the closed position, when the guide plate is not in contact with the work piece and held in any position likely to occur in normal use.

The minimum opening for the plunging movement of the motor with respect to the upper guard may be provided between the guide plate and the lower side of the motor.

Compliance is checked by inspection and measurements.

19.102 Guarding below the guide plate

19.102.1 For saws shown in Figures 101, 102 and 103, the perpendicular projection of the lower guard on to the blade shall cover at least the smallest recommended blade-cutting edge zone, except for the blade exposure specified in 19.102.4.

19.102.2 The lower guard shall return automatically to the closed position when the guide plate is not in contact with the work piece and held in any position likely to occur in normal use.

Compliance is checked by inspection.

19.102.3 For saws having a blade with a diameter less than 210 mm, the closing time of the lower guard from the fully open position to the fully closed position shall not exceed 0,2 s. For saws having a blade diameter 210 mm and above, the closing time of the lower guard from the fully open position to the fully closed position in seconds, shall be less than the numerical equivalent of the largest recommended blade diameter, expressed in metres, but not more than 0,3 s. During measurement, the saw is set to cut at a right angle and for maximum cutting depth, with the guide plate in the horizontal position and the saw not inverted.

Compliance is checked by measurements.

19.102.4 For saws shown in Figures 101 and 102, when the guide plate is not inclined and is set for maximum depth of cut, and the lower guard is in the closed position, the angle $\angle ACB$ of blade exposure, as specified in Figure 112, shall not exceed

- 0°, if the outboard section of the guide plate does not enclose the blade on the side opposite the motor or the principal dimension H of the guide plate, as specified in Figure 113, is less than $0,10 D$;
- 10°, if the outboard section of the guide plate encloses the blade on the side opposite the motor and the principal dimension H of the guide plate as specified in Figure 113, is $0,10 D$ to $0,15 D$;
- 25°, if the outboard section of the guide plate encloses the blade on the side opposite the motor and the principal dimension H of the guide plate, as specified in Figure 113, is greater than $0,15 D$.

Compliance is checked by inspection and by measurement.

19.102.5 For saws with a tow-guard (see Figure 103) the lower guard shall automatically lock in the closed position when the guide plate is not in contact with the work piece and held in any position likely to occur in normal use.

Compliance is checked by inspection.

19.102.6 For saws as shown in Figures 102 and 103 equipped with a riving knife, the lower guard of which needs to allow for the passage of the blade, riving knife and its holder, the apertures in the lower guard shall be kept as small as possible. The aperture in the lower guard shall be designed such that the test probe 'a' of Figure 105 when inserted at any angle and to the depth allowed by its stop, shall not be able to contact the cutting edge zone of the largest recommended blade as illustrated in Figure 106.

Compliance is checked by inspection.

19.103 Guide plate

19.103.1 The guide plate shall surround the lower guard (or blade in the case of plunge saws) at least from the front, rear and the motor side of the lower guard. If the outboard section of the guide plate is removable or hinged, the dimension H shall be measured in the most unfavourable position. The guide plate shall have the following principal dimensions as specified in Figure 113:

$$F > 0,2 D$$

$$H > 0$$

where

D is the diameter of the blade;

F is the dimension from the periphery of the largest recommended blade to the front edge of the guide plate measured along the bottom surface of the guide plate at maximum cutting depth;

H is the dimension from the outside edge of the guide plate on the blade side, to the near surface of the thickest recommended blade of a not inclined guide plate.

Compliance is checked by measurement.

19.103.2 The guide plate dimensions and the weight distribution of the saw shall be such that it does not cause blade binding.

Compliance is checked by the following test.

The saw is set to maximum depth of cut, with blade and riving knife if any, removed. For plunge type saws, Figure 104, the guide plate is fixed to remain at maximum depth. Then the guide plate of the saw is placed on a horizontal flat surface and the lower guard of saws shown in Figures 101, 102 and 103 is fixed in the open position. The saw shall not tip over and the guide plate shall remain the only supporting structure. The test is performed with the guide plate set at 90° and at the maximum bevel setting.

19.104 Flanges

The outer diameter of the contact surface shall be not less than 0,15 times the blade diameter and at least one of the flanges shall be locked or keyed to the output spindle. The overlap of the clamping area of the two flanges shall be at least 1,5 mm wide, as specified in Figure 114.

Compliance is checked by measurement and by inspection.

19.105 Handles

Saws with a maximum recommended blade diameter larger than 140 mm shall have at least two handles.

For saws with a mass less than 6 kg, the motor casing, if suitably shaped, may be considered as a second handle.

Compliance is checked by inspection and by measurement. The mass of the saw is measured without saw blade and without flexible cable or cord.

19.106 Blade changing

Provision shall be made to enable the operator to replace the blade without difficulty.

Examples of such designs are: spindle lock, flats on the outer flange or other means recommended by the manufacturer.

Compliance is checked by inspection.



19.Z101 The saw blade(s) delivered with the tool shall comply with EN 847-1.

Compliance is checked by inspection.

20 Mechanical strength

This clause of Part 1 is applicable except as follows:

20.1 Addition:

For saws with a riving knife, deformations of the lower guard impairing the compliance with 19.102.6 are disregarded, and the functional test of the lower guard system is not performed after the 1 m drop test. For saws without a riving knife, the functional test of the lower guard is performed on a separate sample in accordance with Annex BB.

21 Construction

This clause of Part 1 is applicable except as follows:

21.18 Addition

The mains switch shall automatically switch off the motor as soon as the actuating member of the switch is released.

This switch shall have no locking arrangement in the "on" position.

The mains switch of a saw shall be equipped with a device that automatically locks it in the "off" position when the actuator is released so that two motions are required to energise the tool, or the travel from "off" to "on" of the part of the switch actuator that has the greatest travel shall not be less than 6,4 mm.

The saw, without use of any attachments or modification, shall not be suitable to be used as a stationary tool in the inverted position.

Compliance is checked by inspection.

Ⓒ

21.21 Addition:

Circular saws are considered to be tools where a considerable amount of dust is produced. Ⓒ

22 Internal wiring

This clause of Part 1 is applicable.

23 Components

This clause of Part 1 is applicable.

24 Supply connection and external flexible cords

This clause of Part 1 is applicable.

25 Terminals for external conductors

This clause of Part 1 is applicable.

26 Provision for earthing

This clause of Part 1 is applicable.

27 Screws and connections

This clause of Part 1 is applicable.

28 Creepage distances, clearances and distances through insulation

This clause of Part 1 is applicable.

29 Resistance to heat, fire and tracking

This clause of Part 1 is applicable.

30 Resistance to rusting

This clause of Part 1 is applicable.

31 Radiation, toxicity and similar hazards

This clause of Part 1 is applicable.

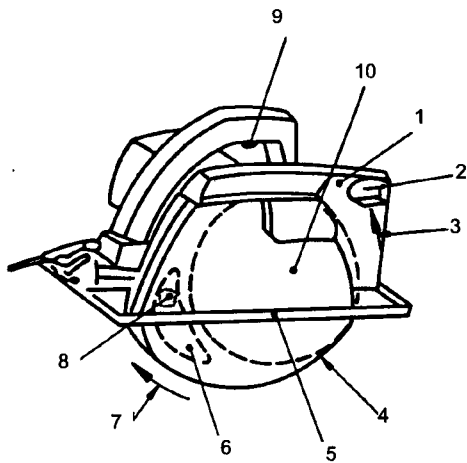

IEC 2978/02

Figure 101 – Circular saw with outer pendulum guard

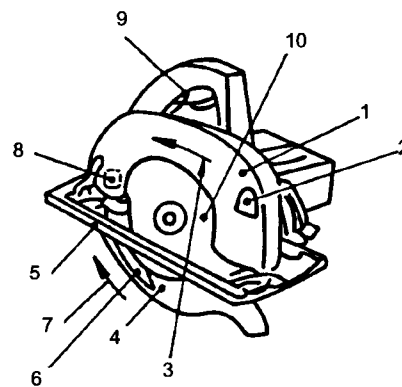

IEC 2979/02

Figure 102 – Circular saw with inner pendulum guard

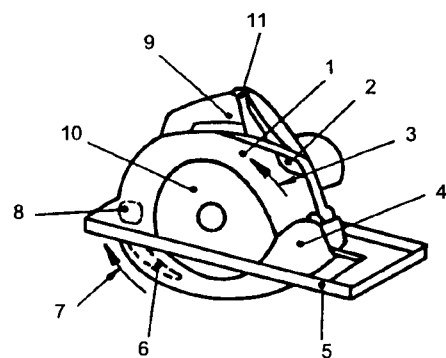

IEC 2980/02

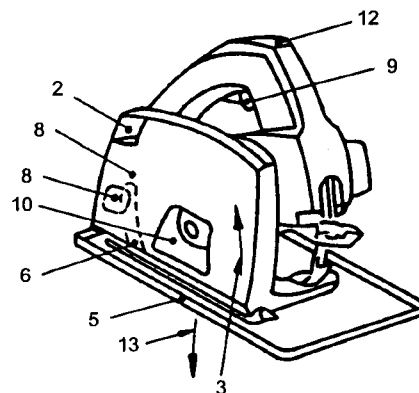

IEC 2981/02

Figure 103 – Circular saw with tow guard

Figure 104 – Plunge type saw

Key to Figures 101 to 104

- | | |
|---|--|
| 1 Upper guard | 7 Direction of lower guard opening |
| 2 Chip ejection port | 8 Holder for riving knife |
| 3 Indication of direction of saw blade rotation | 9 Switch |
| 4 Lower guard | 10 Saw blade |
| 5 Guide plate | 11 Lever for unlocking tow guard lock |
| 6 Riving knife | 12 Lever for unlocking plunge guard lock |
| | 13 Direction of plunging movement |

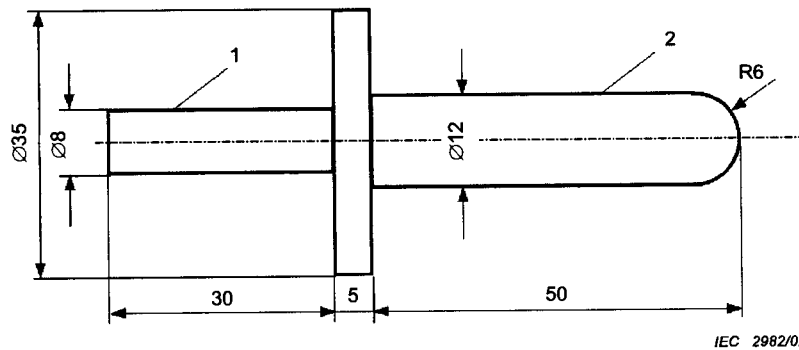

IEC 2982/02

Key

- | | |
|---|----------------|
| 1 | Handle section |
| 2 | Test section |

Dimensions in mm

Figure 105 – Test probe 'a'

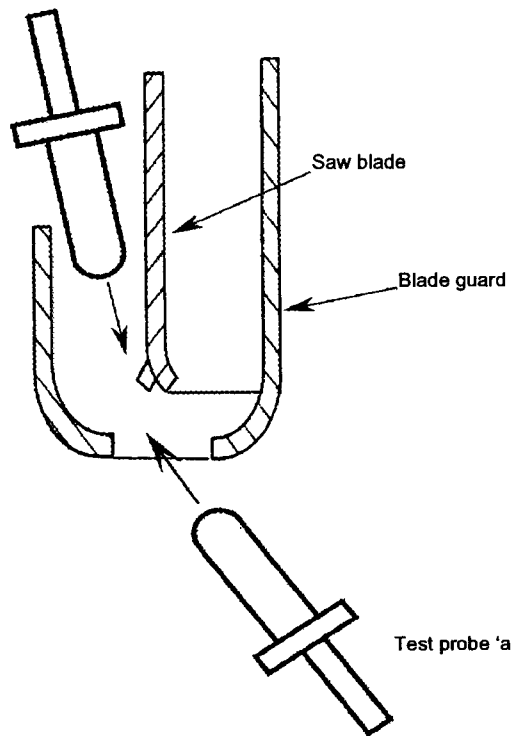

IEC 2983/02

Figure 106 – Aperture for blade and/or riving knife in the lower guard and aperture of the upper guard

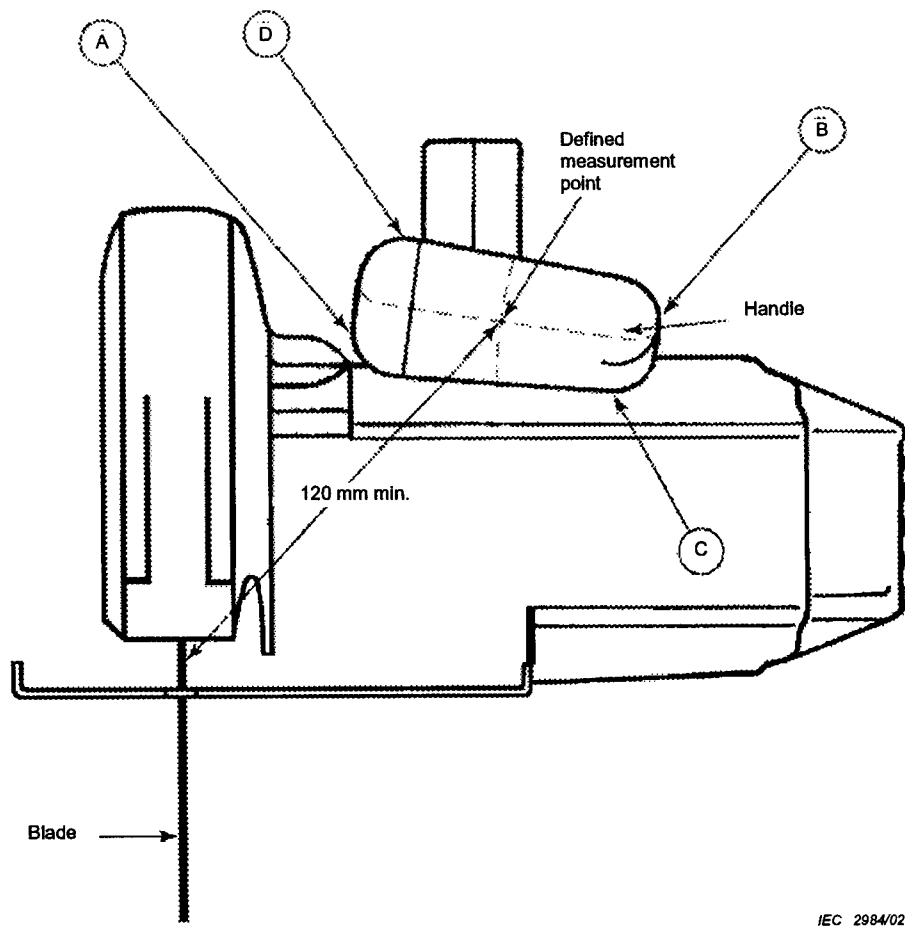

IEC 2984/02

Figure 107 – Distance from the gripping surface to the blade's cutting zone

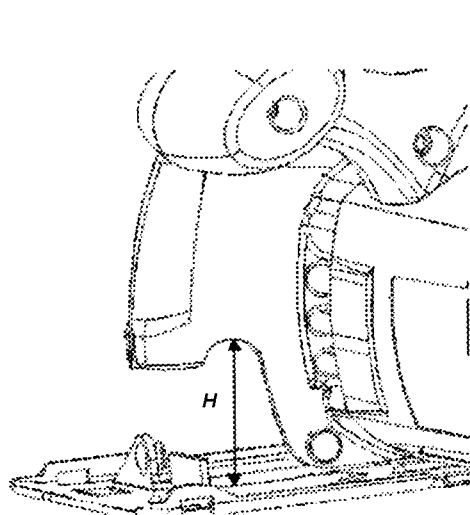

IEC 2985/02

Figure 108a – Height of viewing aperture

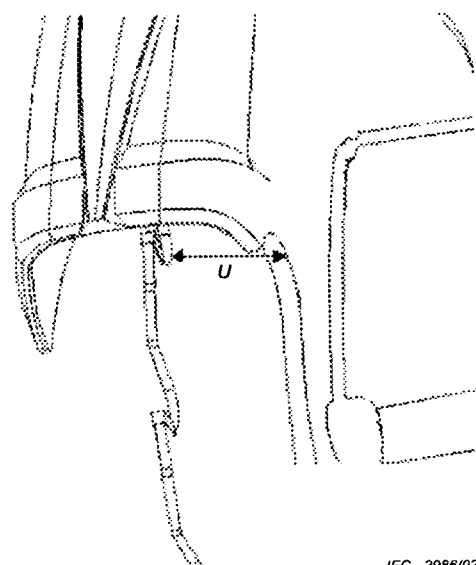

IEC 2986/02

Figure 108b – Dimension U

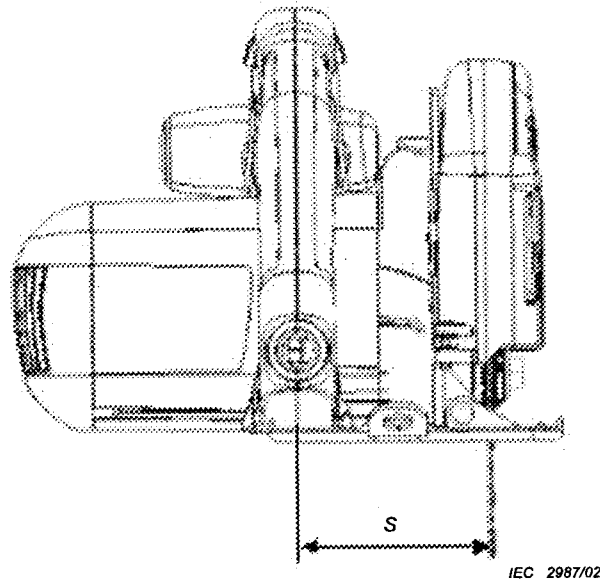
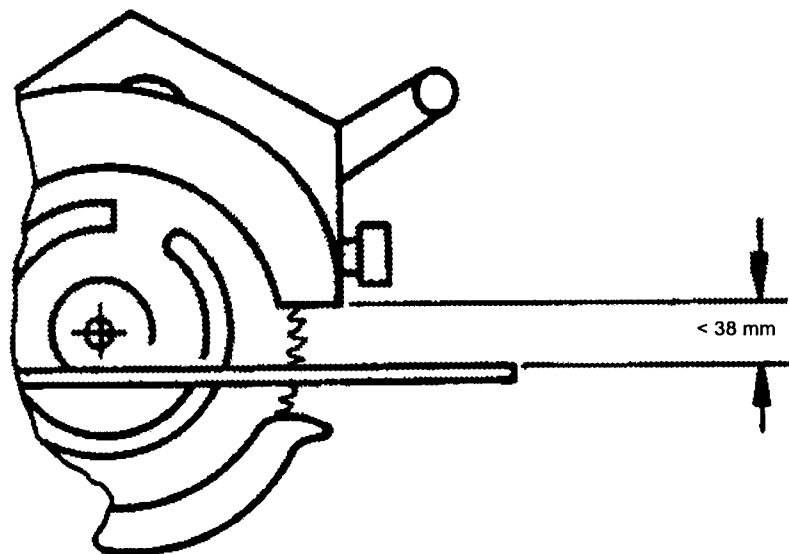

Figure 108c – Dimension S

Figure 108 – Height restriction of the viewing aperture (see 19.101.2.1)



IEC 2988/02

Figure 109 – Distance from the lateral side of the upper guard to the guide plate

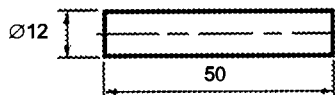

IEC 2989/02

Dimensions in mm

Figure 110 – Test probe 'b'

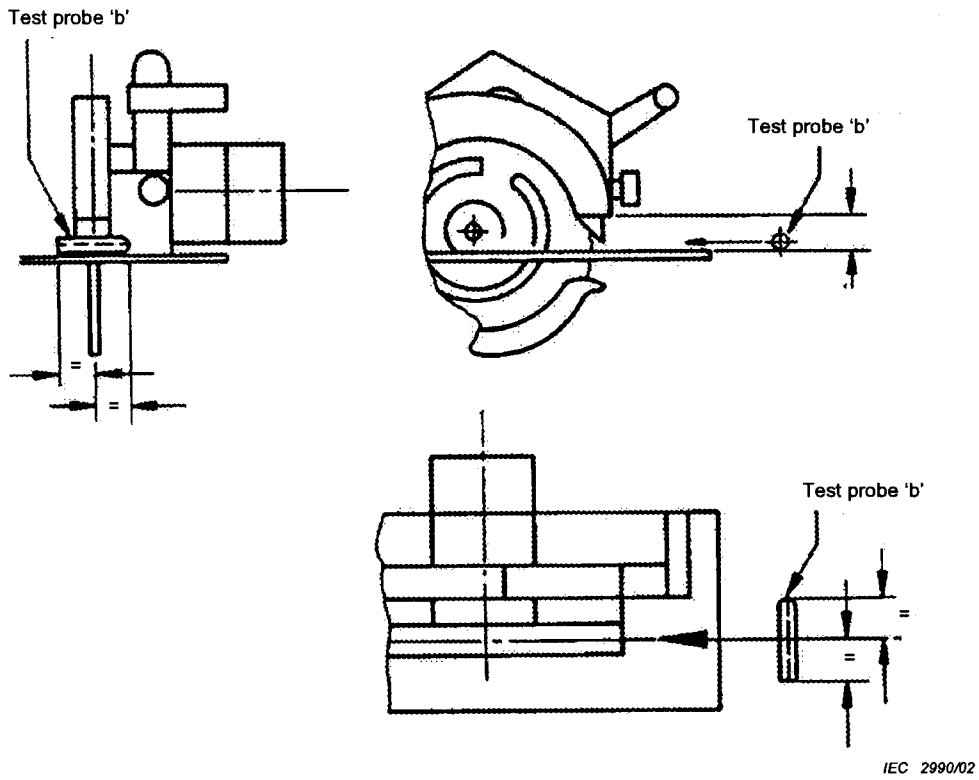
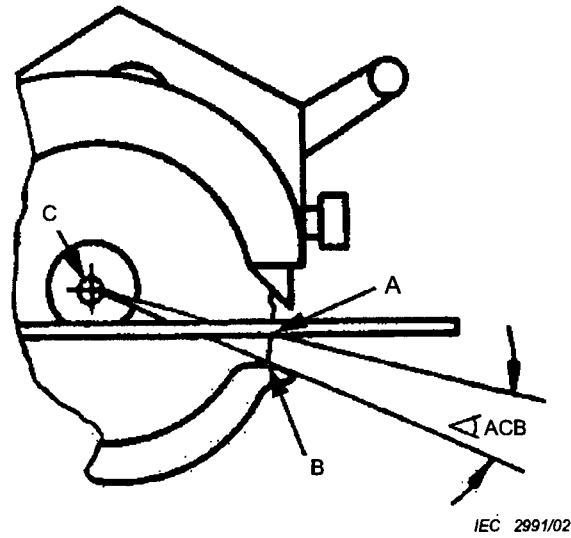

Figure 111 – Accessibility to the front cutting edge zone



Key

- A Blade periphery intersect point with the bottom plane of the guide plate.
- B Blade periphery intersect point with the perpendicular projection onto the blade, of either side or the front tip of the movable guard, that yields the largest $\angle ACB$.
- C Centre of blade.

Figure 112 – Blade exposure angle of the lower guard

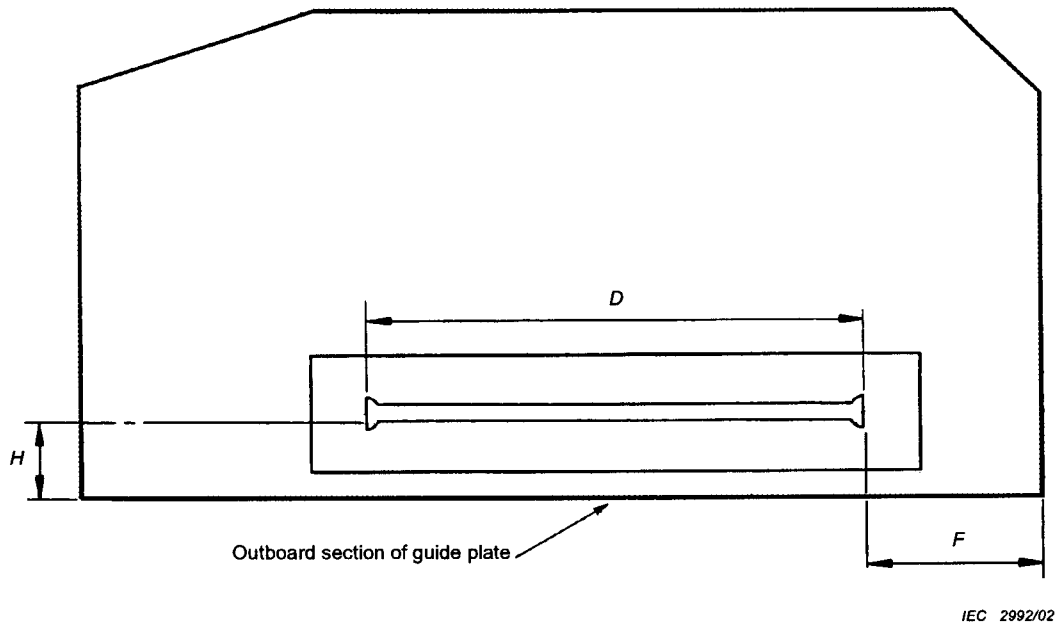

NOTE The shape of the guide plate need not be rectangular nor the one shown

Figure 113 – Principal dimensions of the guide plate

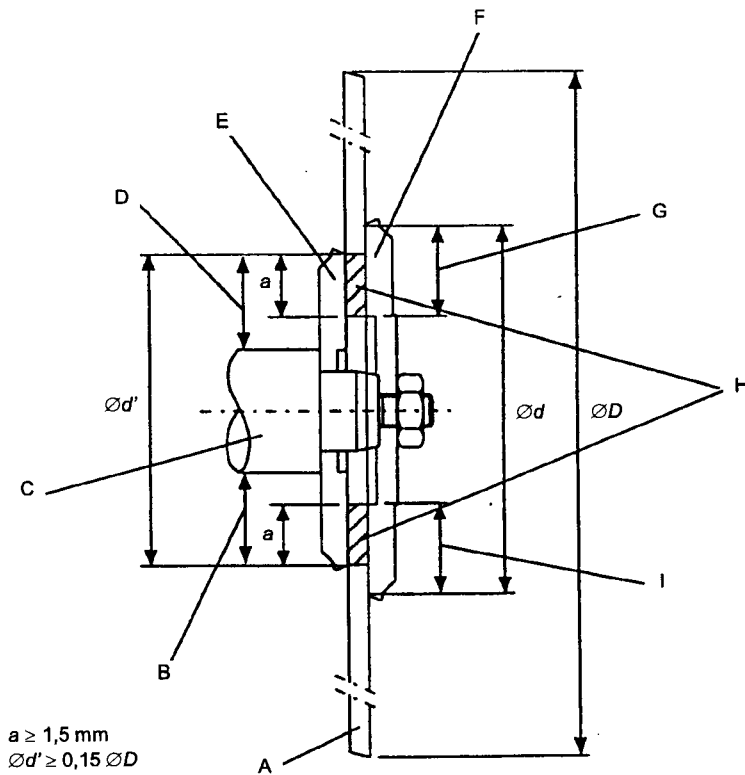

IEC 2993/02

Key

- | | |
|------------------|-------------------|
| A Blade | F Outer flange |
| B Clamping area | G Contact surface |
| C Output spindle | H Overlap surface |
| D Clamping area | I Contact surface |
| E Inner flange | |

Figure 114 – Flange characteristics

Annexes

The annexes of Part 1 are applicable except as follows.

Annex K (normative)

Battery tools and battery packs

K.1.1 Addition:

All clauses of this Part 2 apply unless otherwise specified in this annex.

Annex L (normative)

Battery tools and battery packs provided with mains connection or non-isolated sources

L.1.1 Addition:

All clauses of this Part 2 apply unless otherwise specified in this annex.

Annex AA (normative)

Additional requirements for saws with a riving knife

This annex presents additional requirements for saws with a riving knife. The clause and subclause numbering used here refers to the clauses and subclauses in the main text being complemented by these additional requirements.

AA.19 Mechanical hazards

Riving knives for saws shall meet the requirements of AA.19.101 – AA.19.105:

AA.19.101 The riving knife shall be rigidly fixed within the cutting depth and be in alignment with the plane of the blade and disposed to it so as to pass freely through the cutting groove; it shall not contact the blade. The position of the riving knife shall not change as a result of operation.

Compliance is checked by inspection and by the following test.

The riving knife is adjusted to the maximum distance specified in AA.19.102. The fastening screws of the riving knife are tightened with a torque specified by the manufacturer.

At the centre of the riving knife tip, a force of 100 N is applied for 1 min in the cutting direction and parallel to the guide plate, as shown in Figure AA.101.

During the test, the riving knife shall not touch the blade's cutting edge zone.

After this test, the tip of the riving knife shall not have been displaced by more than 3 mm in direction of the force.

AA.19.102 The riving knife and its holder shall be so designed as to allow the adjustment of the riving knife, for all blade diameters resulting in cutting depths between 100 % and 90 % of the rated cutting depth, to comply with the following conditions of Figure AA.102:

- a) below the guide plate, the radial distance between the riving knife and the edge of the blade shall not at any point exceed 5 mm at the depth of cut set;
- b) the distance from the tip of the riving knife to the rim of the blade shall not exceed 5 mm, when measured along the line perpendicular to the guide plate.

Compliance is checked by inspection and by measurement.

AA.19.103 For saws with a rated cutting depth exceeding 55 mm, the riving knife and its holder shall be so designed that when the cutting depth is adjusted, the riving knife automatically continues to comply with the requirements of items a) and b) of AA.19.102.

Compliance is checked by inspection.

AA.19.104 The riving knife shall be made of steel with a hardness of between 35 HRC and 48 HRC and a resistance to rupture at least equal to 800 MPa.

Its tip shall be rounded, with a radius of not less than 2 mm, and its edges shall not be sharp.

The width of the riving knife, measured at the guide plate level for the maximum cutting depth of the saw, shall be at least equal to 1/8 of the diameter of the blade. Moreover, the faces of the riving knife shall be plane, smooth and parallel and shall be slightly chamfered on the edge facing the blade.

Compliance is checked by inspection, by measurement and by the following test.

The guide plate is set to maximum depth of cut at 90°. The riving knife is adjusted for the maximum recommended saw blade in accordance with AA.19.102. The fastening screws of the riving knife are tightened with the torque specified by the manufacturer.

At the centre of the riving knife tip, a force W equal to the weight of the tool is applied for 1 min in both directions perpendicular to the blade, as shown in Figure AA.101.

After this test, the tip of the riving knife shall not have been displaced in the direction of the force by more than half the thickness of the riving knife.

AA.19.105 The saw shall be designed and made in such a way that it can not rest on the riving knife when placed on a horizontal plane in all its stable positions with the lower guard in the closed position.

Compliance is checked by inspection and by measurement.

AA.20 Mechanical strength

AA.20.2 Addition:

The test is also made on the guarding system. Compliance with the requirements of 19.101, 19.102, and the following is tested after the test of the guarding system.

No breakage shall be visible to the naked eye.

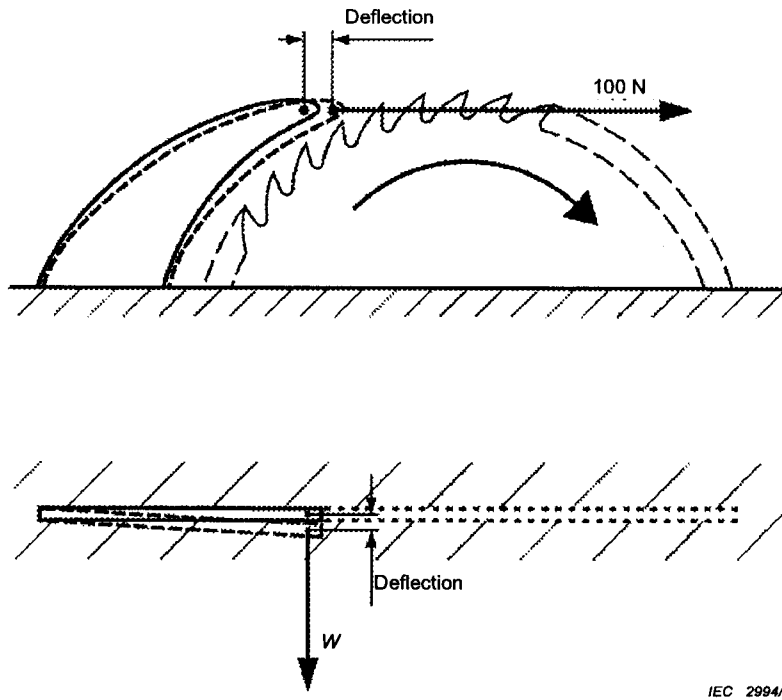

Figure AA.101 – Riving knife stability test

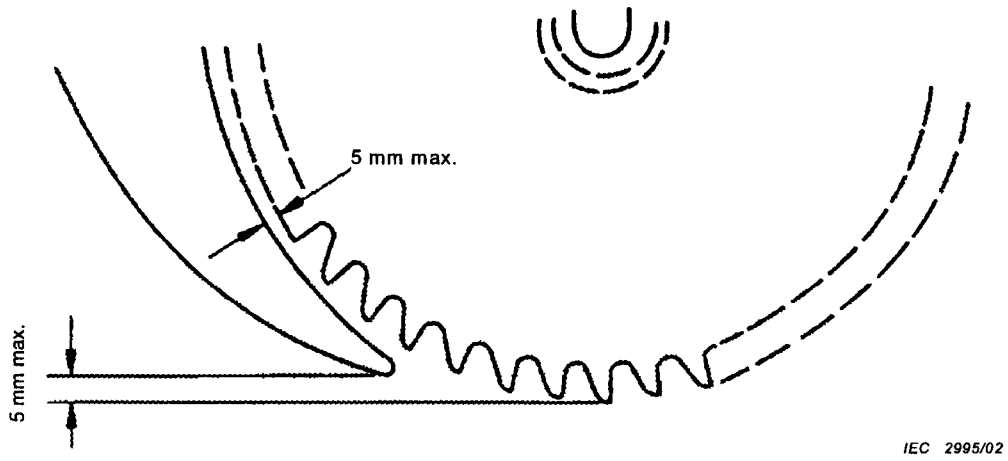

Figure AA.102 – Riving knife adjustment

Annex BB (normative)

Additional requirements for lower guards for saws without a riving knife

This annex presents additional requirements for saws without a riving knife. The clause and subclause numbering used here refers to the clauses and subclauses in the main text being complemented by these additional requirements

BB.20 Mechanical strength

Additional subclauses:

BB.20.101 The lower guard shall be resistant to abuse and dust accumulation.

Compliance is checked by the following tests.

BB.20.101.1 *Sawing 60 m of approximately 12 mm plywood that has been stored indoors for 72 h prior to the sawing. During this test, the dust extraction system shall not be used. The saw then is to be conditioned for 24 h in air at a relative humidity of (93 ± 2) % and within 1 K of any convenient temperature between 20 °C and 30 °C.*

BB.20.101.2 *The saw, set for a 90° cut of maximum depth and oriented so that the lower guard will strike the floor with the guide plate parallel to the floor, is to be dropped once from a height of 1 m to a concrete surface.*

BB.20.101.3 *The saw, set for a 90° cut of maximum depth and oriented in a hand carrying position intended for the particular tool, is to be dropped once from a height of 1 m to a concrete surface.*

The closing time of a lower guard from the fully open position to the fully closed position when measured without restoration of the lower guard in case of bending after a single sample is subjected to BB.20.101.1, BB.20.101.2, and BB.20.101.3 shall not exceed 0,3 s.

BB.20.102 The lower guard shall be durable after extended use.

Compliance is checked by the following test.

The saw is to be set for a 90° cut and oriented in the horizontal plane. The lower guard is to be cycled from the full closed position to the maximum open working position and then released for 50 000 cycles at a rate not less than 10 cycles per minute.

Following the cycling, the closure time shall not exceed 0,3 s. In addition, the lower guard shall be fully functional through its potential range of movements at any guide plate settings.

If agreeable to all concerned, the lower guard system may be tested at a rate faster than 10 cycles per minute. The sample used for this test may be positioned in a manner other than horizontal provided that it can be shown that the alternate position is equivalent.

Bibliography

The bibliography of Part 1 is applicable.

.....