

BRITISH STANDARD

**BS EN
1725:1998**

**Domestic furniture —
Beds and mattresses —
Safety requirements and
test methods**

<http://www.china-gauges.com/>

The European Standard EN 1725:1998 has the status of a
British Standard

ICS 97.140

NO COPYING WITHOUT BSI PERMISSION EXCEPT AS PERMITTED BY COPYRIGHT LAW



5*

National foreword

This British Standard is the English language version of EN 1725:1998. It supersedes BS 7397:1991 which is withdrawn.

The UK participation in its preparation was entrusted to Technical Committee TW6, Beds, which has the responsibility to:

- aid enquirers to understand the text;
- present to the responsible European committee any enquiries on the interpretation, or proposals for change, and keep the UK interests informed;
- monitor related international and European developments and promulgate them in the UK.

A list of organizations represented on this committee can be obtained on request to its secretary.

Cross-references

The British Standards which implement international or European publications referred to in this document may be found in the BSI Standards Catalogue under the section entitled "International Standards Correspondence Index", or by using the "Find" facility of the BSI Standards Electronic Catalogue.

A British Standard does not purport to include all the necessary provisions of a contract. Users of British Standards are responsible for their correct application.

Compliance with a British Standard does not of itself confer immunity from legal obligations.

Summary of pages

This document comprises a front cover, an inside front cover, the EN title page, pages 2 to 10, an inside back cover and a back cover.

Amendments issued since publication

Amd. No.	Date	Text affected

This British Standard, having been prepared under the direction of the Consumer Products and Services Sector Board, was published under the authority of the Standards Board and comes into effect on 15 June 1998

© BSI 1998

ISBN 0 580 29122 7

EUROPEAN STANDARD

EN 1725

NORME EUROPÉENNE

EUROPÄISCHE NORM

January 1998

ICS 97.140

Descriptors: Furniture, beds, mattresses, safety, specifications, accident prevention, tests, mechanical tests, impact tests, stability tests, durability, testing conditions, environment

English version

Domestic furniture — Beds and mattresses — Safety requirements and test methods

Meubles à usage domestique — Lits et matelas —
Exigences de sécurité et méthodes d'essais

Wohnmöbel — Betten und Matratzen —
Sicherheitstechnische Anforderungen und
Prüfverfahren

This European Standard was approved by CEN on 4 December 1997.

CEN members are bound to comply with the CEN/CENELEC Internal Regulations which stipulate the conditions for giving this European Standard the status of a national standard without any alteration. Up-to-date lists and bibliographical references concerning such national standards may be obtained on application to the Central Secretariat or to any CEN member.

This European Standard exists in three official versions (English, French, German). A version in any other language made by translation under the responsibility of a CEN member into its own language and notified to the Central Secretariat has the same status as the official versions.

CEN members are the national standards bodies of Austria, Belgium, Czech Republic, Denmark, Finland, France, Germany, Greece, Iceland, Ireland, Italy, Luxembourg, Netherlands, Norway, Portugal, Spain, Sweden, Switzerland and United Kingdom.

CEN

European Committee for Standardization
Comité Européen de Normalisation
Europäisches Komitee für Normung

Central Secretariat: rue de Stassart 36, B-1050 Brussels

© 1998 CEN All rights of exploitation in any form and by any means reserved worldwide for CEN national Members.

Ref. No. EN 1725:1998 E

Foreword

This European Standard has been prepared by Technical Committee CEN/TC 207, Furniture, the secretariat of which is held by IBN.

This European Standard shall be given the status of a national standard, either by publication of an identical text or by endorsement, at the latest by July 1998, and conflicting national standards shall be withdrawn at the latest by July 1998.

According to the CEN/CENELEC Internal Regulations the national standards organizations of the following countries are bound to implement this European Standard: Austria, Belgium, Czech Republic, Denmark, Finland, France, Germany, Greece, Iceland, Ireland, Italy, Luxembourg, Netherlands, Norway, Portugal, Spain, Sweden, Switzerland and the United Kingdom.

Contents

	Page
Foreword	2
Introduction	3
1 Scope	3
2 Normative references	3
3 Definitions	3
4 General test conditions	3
5 Test environment and apparatus	4
6 Safety requirements	5
7 Test methods	7
8 Test report	8
Annex A (informative) Details of two versions of the edge loading pad	9

Introduction

This European Standard has been prepared in order to provide assurance that domestic beds complying with the requirements are reasonably safe.

It is intended to prevent serious injury through normal functional use, as well as misuse that might reasonably be expected to occur.

It should be understood that the tests do not ensure that structural failure will not eventually occur as a result of habitual misuse or after an excessively long period of use.

1 Scope

This European Standard specifies mechanical safety requirements and testing for all types of fully erected domestic adult beds including all component elements such as bed frame, bed base, mattress and mattress pads (when they form a unit with the mattress). It does not apply to foldaway beds, bunk beds, children's cots and adjustable beds for disabled persons where separate standards exist, as well as waterbeds and air beds.

Further tests may be applicable for test units that are multi-purpose, e.g. convertible sofa beds and power driven systems.

Assessment for ageing and degradation are not included.

2 Normative references

This European Standard incorporates, by dated or undated reference, provisions from other publications. These normative references are cited at the appropriate places in the text and the publications are listed hereafter. For dated references, subsequent amendments to or revisions of any of these publications apply to this European Standard only when incorporated in it by amendment or revision. For undated references, the latest edition of the publication referred to applies.

EN 1022, *Domestic furniture — Seating — Determination of stability.*

ISO 2439, *Flexible cellular polymeric materials — Determination of hardness (indentation technique).*

3 Definitions

For the purposes of this standard the following definitions apply.

3.1

unframed slat base

bed base consisting of separate slats flexibly held together normally by means of textile, rubber or plastic tape

NOTE When loading one slat, the load is transferred to the support by that slat only.

3.2

framed base

bed base consisting of slats, springs, etc., which are connected to a structural frame system

NOTE When loading one component only, e.g. a slat or a spring, the load is distributed to the frame to the support.

3.3

framed sprung mattress

upholstered bed base consisting of springs, topped with fillings, on a rigid frame to be used in a bed frame or freestanding

3.4

divan base

upholstered bed base used without the need of any framework. It may be constructed with a spring filling or a solid top and may include drawers or storage facilities

4 General test conditions

4.1 Preliminary preparation

Before any of the tests are commenced, the test unit shall be old enough to ensure that it has developed its full strength.

The test unit shall be tested as delivered. Knock-down furniture shall be assembled according to the instructions supplied with it. If the test unit can be assembled or combined in different ways, the most adverse combination shall be used for each test. Knock-down fittings shall be tightened before testing if applicable. Further tightening shall not take place unless this is specifically required by the manufacturer. The test unit shall be stored in indoor ambient conditions for at least one week immediately prior to testing. Any deviation from this procedure shall be stated in the report.

The tests shall be carried out in indoor ambient conditions, but if during a test the atmospheric temperature is outside the range 15 °C to 25 °C, the maximum and/or minimum temperature shall be recorded in the test report.

4.2 Test equipment

The forces in static load and durability tests shall be applied sufficiently slowly to ensure that negligible dynamic load is applied.

Test forces, unless otherwise stated, may be applied by any suitable device because results are not dependent upon the apparatus.

4.3 Tolerances

Unless otherwise stated:

- all forces shall have an accuracy of $\pm 5\%$ of the nominal force;
- all masses shall have an accuracy of $\pm 0,5\%$ of the nominal mass;
- all dimensions shall have an accuracy of ± 1 mm of the nominal dimension.

The tolerance for position of loading pads shall be ± 5 mm.

4.4 Sequence of testing

All tests specified for a particular part shall be carried out on the same sample.

The tests shall be carried out in the sequence laid down in this standard.

5 Test environment and apparatus

5.1 Floor surface

Rigid, horizontal and flat.

5.2 Stops

Stops shall be used to prevent the bed from sliding but not tilting and shall be no higher than 12 mm, except in cases where the design of the bed requires the use of higher stops; in which case the lowest that will prevent the bed from moving, shall be used.

5.3 Standard test mattress

Flexible polyether foam with a thickness of 100 mm, a density of $(30 \pm 2) \text{ kg/m}^3$ and an indentation hardness index of $(170 \pm 20) \text{ N}$ in accordance with A40 in ISO/DIS 2439. The size of the mattress shall be such as to overlap the size of the loading pad by at least 100 mm all round.

The test mattress shall have a cover with the following characteristics:

- composition: pure cotton;
- weave in plain: 1/1;
- mass per unit area: 100 g/m^2 to 120 g/m^2 ;
- warp and weft: 20 threads/cm to 30 threads/cm;
- finishing: washed, no finishing agents;
- cover make up: tight fit, but no restriction on the foam.

Each test mattress shall be used for no more than five complete bed tests.

5.4 Standard test bed base (unframed)

Slats made of wooden materials with a modulus of elasticity of $(1000 \pm 200) \text{ N/mm}^2$.

The cross section of the slats shall be $20 \text{ mm} \times 95 \text{ mm}$ and the distance between the slats $(60 \pm 2) \text{ mm}$.

If the free span of the slats is $> 1000 \text{ mm}$ support the slats along the centre line.

The length of the slats shall be 10 mm shorter than the nominal width of the bed frame.

5.5 Standard test bed base (framed)

Slats as described in 5.4.

The slats shall be mounted on a frame made of wooden material defined in 5.4 with a cross section of $45 \text{ mm} \times 20 \text{ mm}$ (see Figure 1).

The width of the bed base shall be 20 mm smaller than the nominal width of the bed frame.

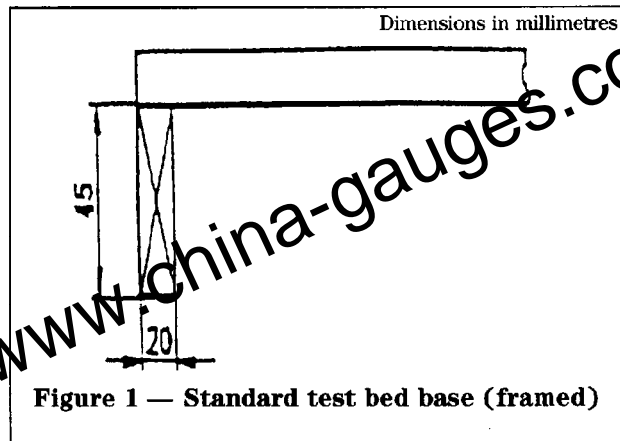

Figure 1 — Standard test bed base (framed)

5.6 Standard test support (unframed bed bases)

The base shall be suitably supported along its whole length.

The total overhang on one side (see Figure 2) shall be $(20 \pm 1) \text{ mm}$.

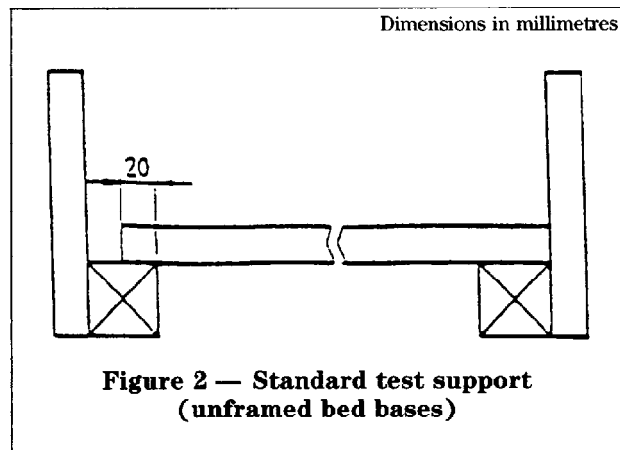

Figure 2 — Standard test support (unframed bed bases)

5.7 Standard test support (framed bed bases)

Supports of 50 mm width, suitable to carry the bed base and the test loads, shall be placed 150 mm from the ends of the frame (see Figure 3).

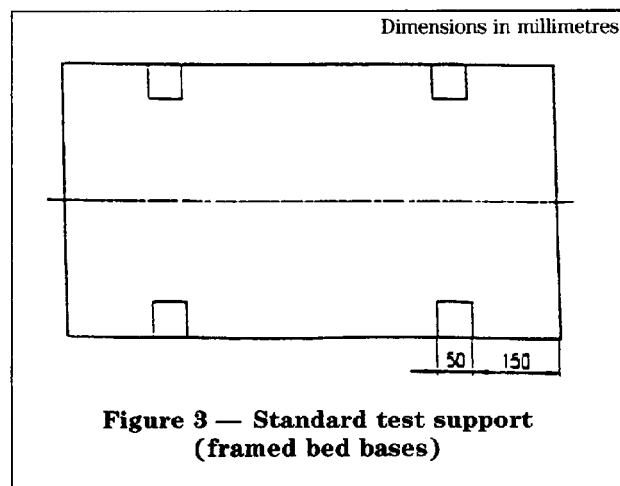

Figure 3 — Standard test support (framed bed bases)

5.8 Loading pad

Rigid circular object 200 mm in diameter the face of which has a convex spherical curvature of 300 mm radius with a 12 mm front edge radius (see Figure 4).

The loading pad shall be rigidly mounted to the loading system of the test machine.

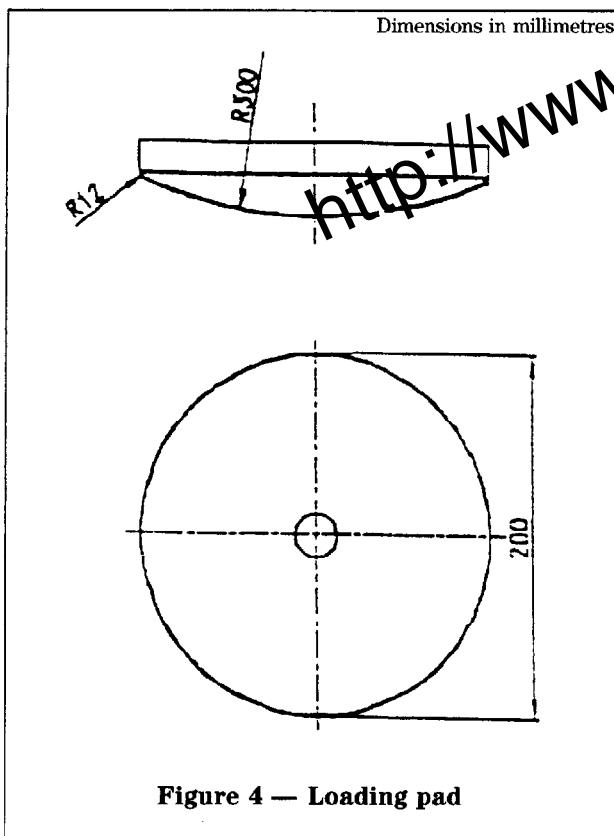

Figure 4 — Loading pad

5.9 Edge loading pad

Naturalistically shaped rigid indenter with a hard, smooth surface having overall dimensions within the limits shown in Figures A.1 and A.2.

The loading pad shall be mounted to the test machine so that it can pivot in the vertical plane about its transverse axis.

Two versions are shown in annex A:

- machined from hardwood as shown in Figure A.1;
- moulded from fibre glass as shown in Figure A.2.

5.10 Impactor (see Figure 5)

5.10.1 Circular body, approximately 200 mm in diameter, separated from the striking surface by helical compression springs and free to move relative to it on a line perpendicular to the plane of the central area of the striking surface.

The body and associated parts minus the springs shall have a mass of $(17 \pm 0,1)$ kg and the whole apparatus, including body, springs and striking surface, shall have a mass of $(25 \pm 0,1)$ kg.

5.10.2 Springs, which shall be such that the combined spring system has a nominal spring rate of $(6,9 \pm 1)$ N/mm and the total friction resistance of the moving parts is between 0,25 N and 0,45 N.

The spring system shall be compressed to an initial load of (1040 ± 5) N (measured statically) and the amount of spring compression movement available from the initial compression point to the point where the springs become fully closed shall be not less than 60 mm.

5.10.3 Striking surface shall be a rigid circular object, 200 mm in diameter, the surface of which has a convex spherical curvature of 300 mm radius with a 12 mm front edge radius.

5.11 Small loading pad

Rigid cylindrical object, 100 mm in diameter, having a smooth hard surface and rounded edges with radius 12 mm.

6 Safety requirements

All components or parts of the bed, with which the user may come into contact during normal use, shall not have burrs and/or sharp edges, nor shall there be open-ended tubes.

When the bed is fully erected and ready for use, all accessible mechanisms that facilitate frame movement shall have safety distances between any two elements moving relative to each other which shall always be ≤ 8 mm or ≥ 25 mm.

When there is a specific danger of feet being trapped by a moving part, the safety distance shall always be ≥ 100 mm from the floor.

When tested according to 7.2, "Stability", the test unit shall not overturn.

All components shall pass the tests specified in clause 7 without fracture (see Table 1).

After testing, there shall be no deformation that may compromise safety.

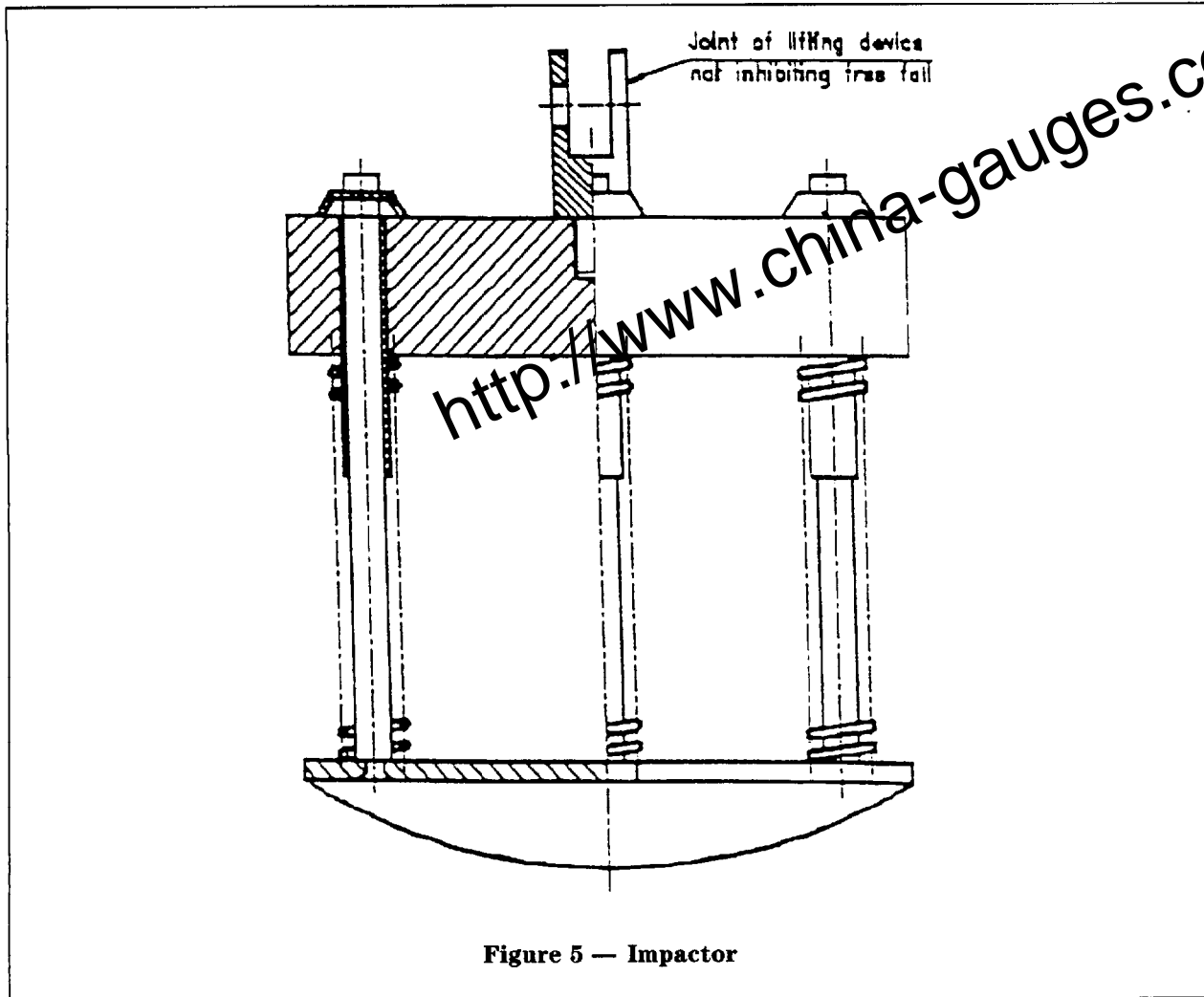

Figure 5 — Impactor

7 Test methods

7.1 General

When mattress, bed base and frame (if applicable) are supplied together as a bed set, they shall be tested together.

When a mattress is supplied separately, it shall be tested on a flat rigid horizontal surface.

When other components are supplied separately, they shall be tested using the standard test mattress, standard test support or standard test bed base described in clause 5, unless otherwise specified by the manufacturer of the component under test.

Except for the stability test according to 7.2, restrain the test unit under test in a suitable manner to prevent tipping under the action of applied forces.

Because of the possibility of an asymmetrical construction of beds and mattresses, the positions of the loading points can differ from the positions defined by the standard.

Table 1 shows which tests are applicable to a bed set and which to parts of a bed.

Table 1 — Testing of beds, bed frames, bed bases, mattresses

Test	7.2	7.3	7.4	7.5	7.6	7.7
Complete bed	x	x	x	x	x	x
Mattress	—	x	x	x	x	—
Bed base	(x)	x	x	(x)	x	(x)
Bed frame	x	x	x	x	x	x

(x) = if applicable.
x = test to be carried out.

Unless otherwise stated, the tests shall be carried out with adjustable parts of the bed base in horizontal or lowest position.

7.2 Stability

The test shall be carried out in accordance with EN 1022, except that the position of the loading points shall be as shown in Figure 6.

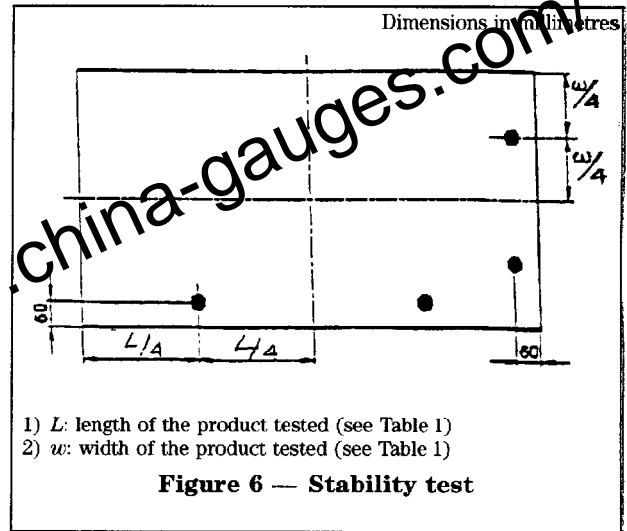

7.3 Durability test

Apply a vertical downward force of 1 000 N using the loading pad (see 5.8).

Apply the load 10 000 times at each position point shown in Figure 7.

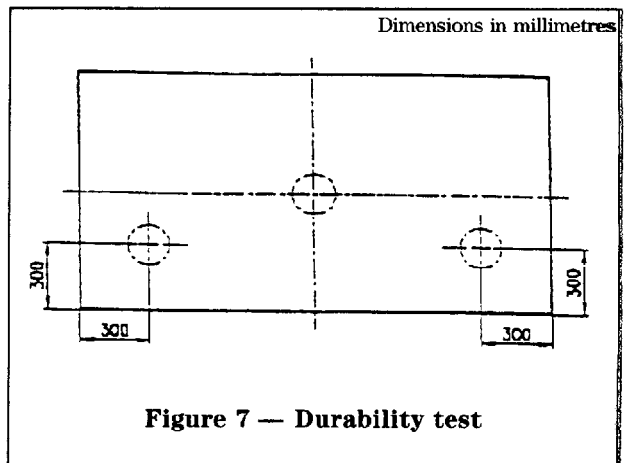

During each application maintain the load for (3 ± 1) s. In the case of an adjustable bed base, the test shall be carried out with adjustable parts in a position as close as possible to 7° above the horizontal.

In the case where the supporting structure of head and feet is identical, the test shall be performed in the middle and to one end only.

7.4 Vertical impact test

Allow the impactor (see 5.10) to fall freely from a height of 180 mm (measured from the top face of the unloaded mattress) onto the mattress, at the following positions (see Figure 8):

- test units greater than 1 150 mm in width: A, B, D, E, G, I and J;
- test units equal to or less than 1 150 mm in width: A, B, C, D, G, I and J.

Carry out ten impacts at each point.

In the case of an adjustable bed base, the test shall be carried out with adjustable parts in a position as close as possible to 7° above the horizontal.

In the case where the supporting structure of head and feet is identical, the test shall be performed in the middle and to one end only.

The centre of the pad and the points A, C, D, G, I and J shall be located at 150 mm from the edge of the bed.

7.5 Durability of bed edge

Apply a force of 1 000 N for 5 000 cycles by means of the edge loading pad (see 5.9).

Testing shall be carried out on one edge at the middle of the length.

The load application point shall be 300 mm from the edge of the top surface of the mattress.

During each application maintain the force for (3 ± 1) s.

7.6 Vertical static load test

Apply a vertical force of 1 400 N downwards using the loading pad (see 5.8).

Apply the load ten times at any point of the bed base where failure is considered likely to occur.

During each application maintain the load for (10 ± 1) s.

7.7 Vertical static load test of the edge of the bed

Using two loading pads (see 5.11) apply two forces of 1 200 N simultaneously for 1 min on the centre line (M) of the bed frame side member.

The loads shall be applied on points 600 mm apart, as shown in Figure 9.

If the bed tends to overturn, the bed shall be loaded sufficiently to prevent it from overturning.

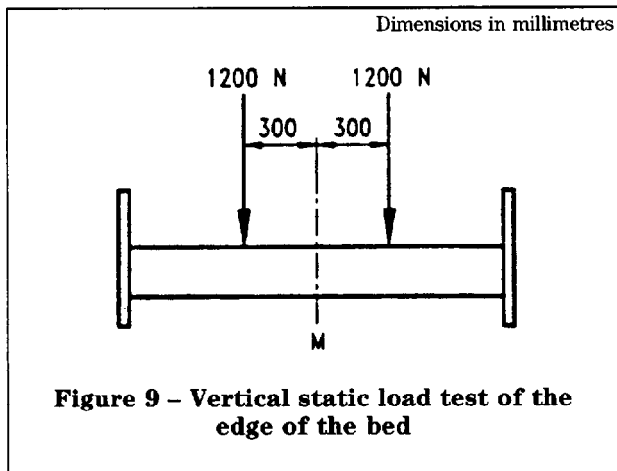
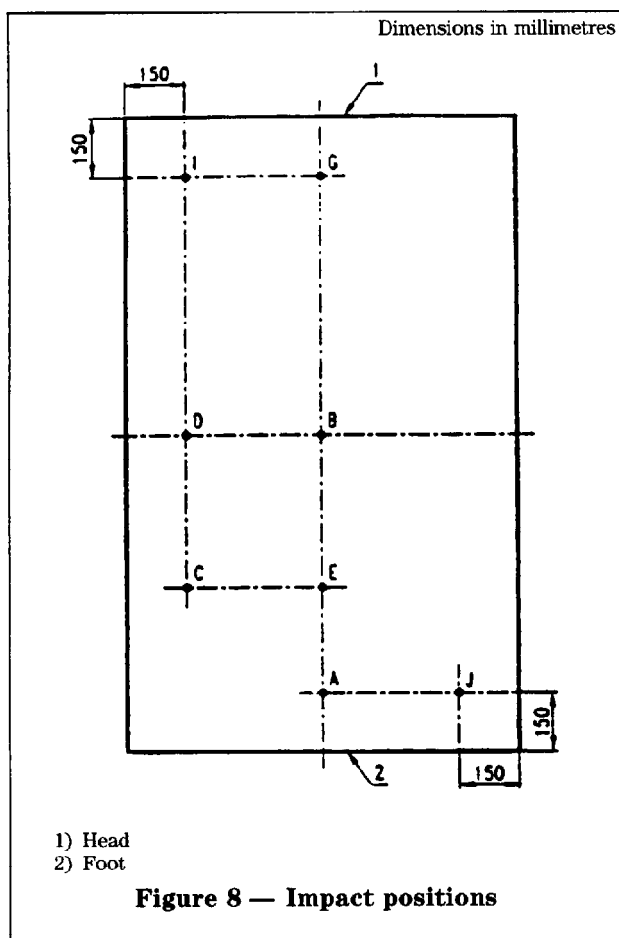

8 Test report

The test report shall include at least the following information:

- a) a reference to EN 1725;
- b) the unit tested;
- c) test results according to 7.2 to 7.7;
- d) compliance with requirements according to EN 1725;
- e) details of any deviation from EN 1725;
- f) the name and address of the test laboratory;
- g) the date of the tests.

Annex A (informative)

Details of two versions of the edge loading pad

The loading pad specified in 5.9 currently exists in two versions:

- 1) machined in hardwood as shown in Figure A.1;
- 2) moulded from fibre glass as shown in Figure A.2.

They may be made from any material which satisfied the requirements of 5.9.

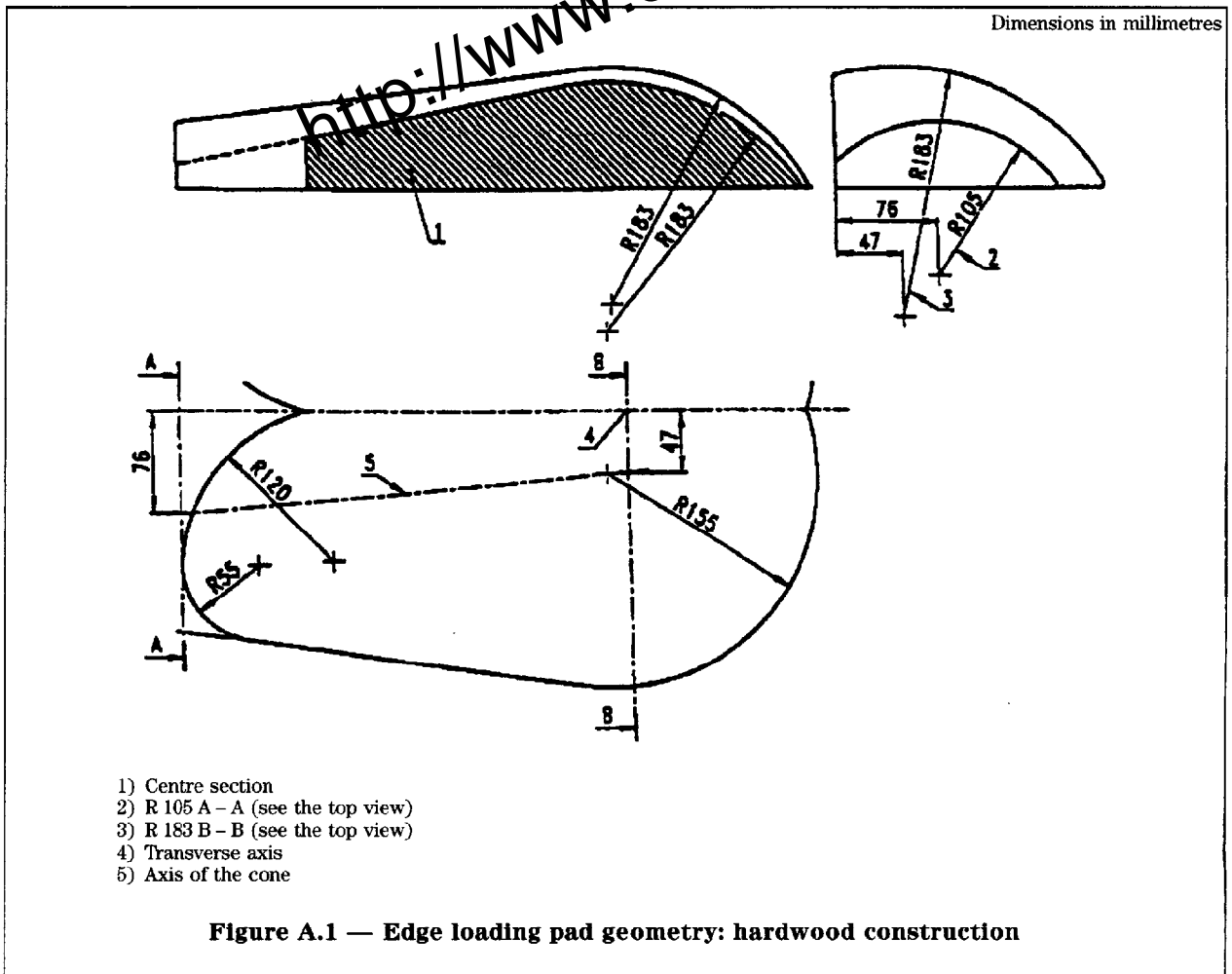

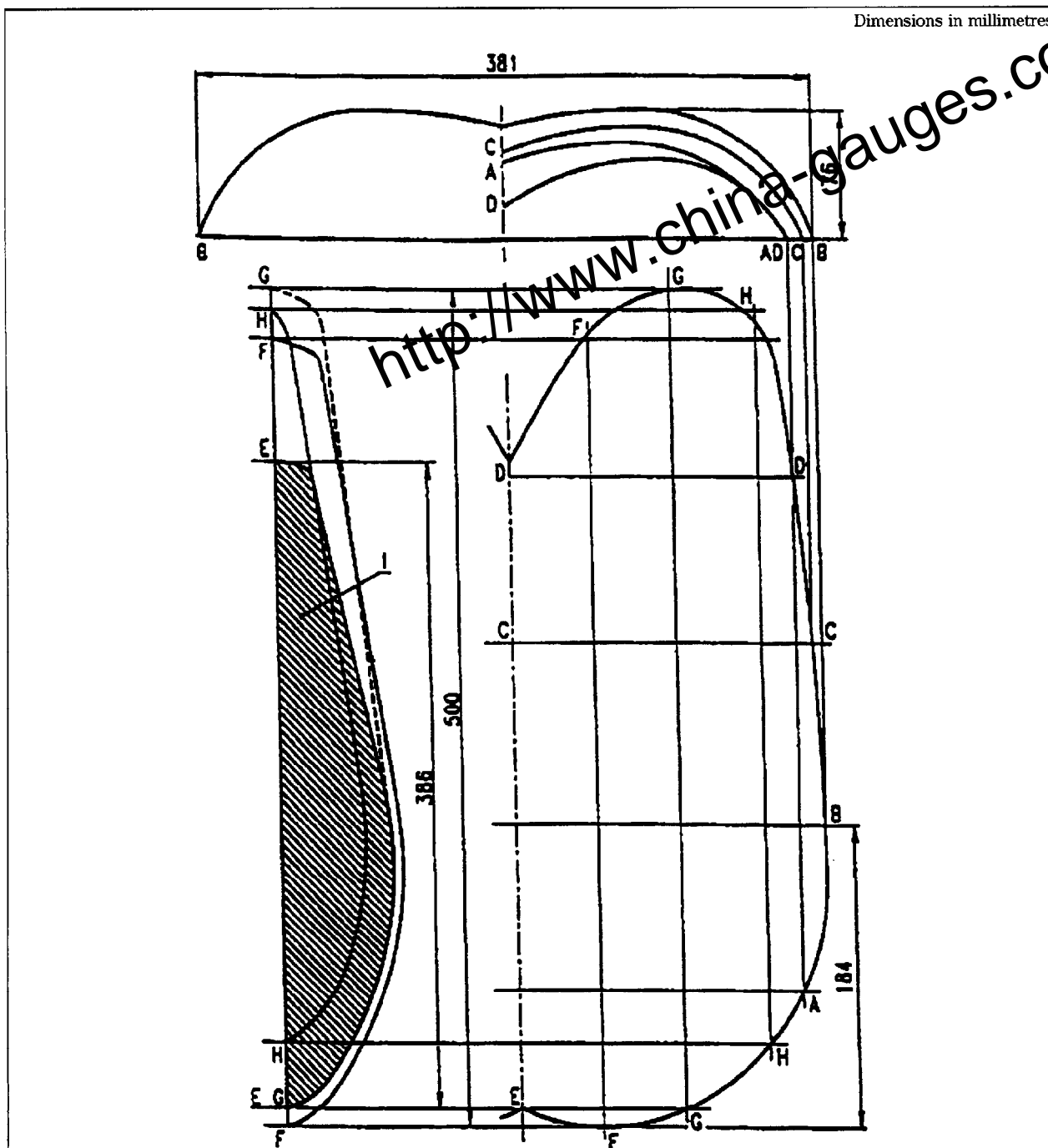

1) Centre section

Figure A.2 — Edge loading pad geometry: moulded fibre glass construction

BS EN
1725:1998

BSI — British Standards Institution

BSI is the independent national body responsible for preparing British Standards. It presents the UK view on standards in Europe and at the international level. It is incorporated by Royal Charter.

Revisions

British Standards are updated by amendment or revision. Users of British Standards should make sure that they possess the latest amendments or editions.

It is the constant aim of BSI to improve the quality of our products and services. We would be grateful if anyone finding an inaccuracy or ambiguity while using this British Standard would inform the secretary of the technical committee responsible, the identity of which can be found on the inside front cover. Tel: 0181 996 9000. Fax: 0181 996 7400.

BSI offers subscribers an individual updating service called PLUS which ensures that subscribers automatically receive the latest editions of standards.

Buying standards

Orders for all BSI, international and foreign standards publications should be addressed to Customer Services. Tel: 0181 996 7000. Fax: 0181 996 7001.

In response to orders for international standards, it is BSI policy to supply the BSI implementation of those that have been published as British Standards, unless otherwise requested.

Information on standards

BSI provides a wide range of information on national, European and international standards through its Library and its Technical Help to Exporters Service. Various BSI electronic information services are also available which give details on all its products and services. Contact the Information Centre. Tel: 0181 996 7111. Fax: 0181 996 7048.

Subscribing members of BSI are kept up to date with standards developments and receive substantial discounts on the purchase price of standards. For details of these and other benefits contact Membership Administration. Tel: 0181 996 7002. Fax: 0181 996 7001.

Copyright

Copyright subsists in all BSI publications. BSI also holds the copyright, in the UK, of the publications of the international standardization bodies. Except as permitted under the Copyright, Designs and Patents Act 1988 no extract may be reproduced, stored in a retrieval system or transmitted in any form or by any means – electronic, photocopying, recording or otherwise – without prior written permission from BSI.

This does not preclude the free use, in the course of implementing the standard, of necessary details such as symbols, and size, type or grade designations. If these details are to be used for any other purpose than implementation then the prior written permission of BSI must be obtained.

If permission is granted, the terms may include royalty payments or a licensing agreement. Details and advice can be obtained from the Copyright Manager. Tel: 0181 996 7070.

BSI
389 Chiswick High Road
London
W4 4AL