

BS EN 60335-2-2:2010+A1:2013

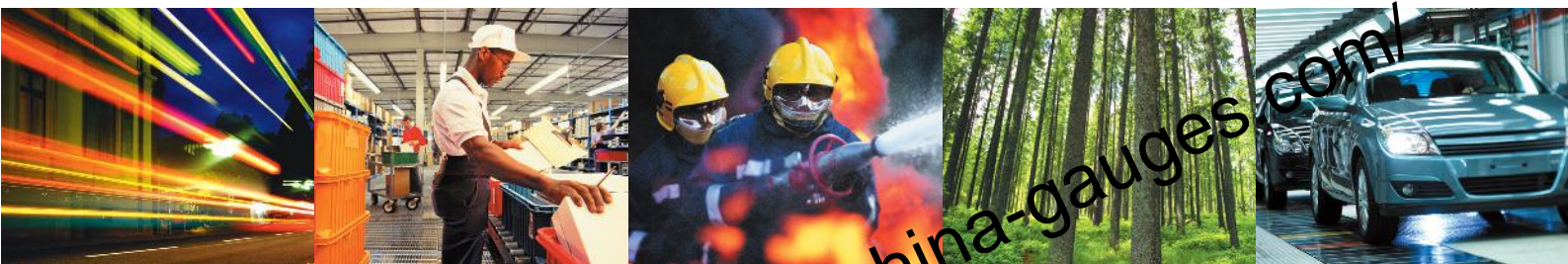

BSI Standards Publication

<http://www.china-gauges.com/>

Household and similar electrical appliances — Safety

Part 2-2: Particular requirements for vacuum cleaners and water-suction cleaning appliances

bsi.

...making excellence a habit.™

National foreword

This British Standard is the UK implementation of EN 60335-2-2:2010+A1:2013. It is derived from IEC 60335-2-2:2009, incorporating amendment 1:2012. It supersedes BS EN 60335-2-2:2010+A11:2012, which will be withdrawn on 20 December 2015.

The start and finish of text introduced or altered by an amendment is indicated in the text by tags. Tags indicating changes to IEC text carry the number of the IEC amendment. For example, text altered by IEC amendment 1 is indicated by $\Delta 1$.

Where a common modification has been introduced by amendment, the tags carry the number of the amendment. For example, the common modifications introduced by CENELEC amendment A11 are indicated by \square_{A11} .

The UK participation in its preparation was entrusted by Technical Committee CPL/61, Safety of household and similar electrical appliances, to Subcommittee CPL/61/1, Motorised appliance group.

A list of organizations represented on this subcommittee can be obtained on request to its secretary.

This publication does not purport to include all the necessary provisions of a contract. Users are responsible for its correct application.

© The British Standards Institution 2013. Published by BSI Standards Limited 2013

ISBN 978 0 580 77915 2

ICS 97.080

Compliance with a British Standard cannot confer immunity from legal obligations.

This British Standard was published under the authority of the Standards Policy and Strategy Committee on 31 May 2010.

Amendments/corrigenda issued since publication

Date	Text affected
30 November 2012	Implementation of CENELEC amendment A11:2012
31 July 2013	Implementation of IEC amendment 1:2012 with CENELEC endorsement A1:2013

English version

**Household and similar electrical appliances -
Safety -
Part 2-2: Particular requirements for vacuum cleaners
and water suction cleaning appliances
(IEC 60335-2-2:2009)**

Appareils électrodomestiques
et analogues -
Sécurité -
Partie 2-2: Règles particulières
pour les aspirateurs et les appareils
de nettoyage à aspiration d'eau
(CEI 60335-2-2:2009)

Sicherheit elektrischer Geräte
für den Hausgebrauch
und ähnliche Zwecke -
Teil 2-2: Besondere Anforderungen
für Staubsauger und Wassersauger
(IEC 60335-2-2:2009)

This European Standard was approved by CENELEC on 2010-02-01. CENELEC members are bound to comply with the CEN/CENELEC Internal Regulations which stipulate the conditions for giving this European Standard the status of a national standard without any alteration.

Up-to-date lists and bibliographical references concerning such national standards may be obtained on application to the Central Secretariat or to any CENELEC member.

This European Standard exists in three official versions (English, French, German). A version in any other language made by translation under the responsibility of a CENELEC member into its own language and notified to the Central Secretariat has the same status as the official versions.

CENELEC members are the national electrotechnical committees of Austria, Belgium, Bulgaria, Croatia, Cyprus, the Czech Republic, Denmark, Estonia, Finland, France, Germany, Greece, Hungary, Iceland, Ireland, Italy, Latvia, Lithuania, Luxembourg, Malta, the Netherlands, Norway, Poland, Portugal, Romania, Slovakia, Slovenia, Spain, Sweden, Switzerland and the United Kingdom.

CENELEC

European Committee for Electrotechnical Standardization
Comité Européen de Normalisation Electrotechnique
Europäisches Komitee für Elektrotechnische Normung

Central Secretariat: Avenue Marnix 17, B - 1000 Brussels

Foreword

The text of document 61/3871/FDIS, future edition 6 of IEC 60335-2-2, prepared by IEC TC 61, Safety of household and similar electrical appliances, was submitted to the IEC-CENELEC parallel vote and was approved by CENELEC as EN 60335-2-2 on 2010-02-01.

This European Standard supersedes EN 60335-2-2:2003 + A1:2004 + A2:2006.

The principal change in EN 60335-2-2:2010 as compared with EN 60335-2-2:2003 is as follows (minor changes are not listed):

- the text is aligned with EN 60335-1:2002, and its amendments A1:2004 and A2:2006 (see text marked with a marginal bar).

Attention is drawn to the possibility that some of the elements of this document may be the subject of patent rights. CEN and CENELEC shall not be held responsible for identifying any or all such patent rights.

The following dates were fixed:

- latest date by which the EN has to be implemented at national level by publication of an identical national standard or by endorsement (dop) 2010-11-01
- latest date by which the national standards conflicting with the EN have to be withdrawn (dow) 2015-02-01

This Part 2 has to be used in conjunction with EN 60335-1, Household and similar electrical appliances – Safety – Part 1: General requirements. It was established on the basis of the 2002 edition of that standard. Amendments and revisions of Part 1 have also to be taken into account and the dates when such changes become applicable will be stated in the relevant amendment or revision of Part 1.

This Part 2 supplements or modifies the corresponding clauses of EN 60335-1, so as to convert it into the European Standard: Safety requirements for vacuum cleaners and water-suction cleaning appliances.

When a particular subclause of Part 1 is not mentioned in this Part 2, that subclause applies as far as is reasonable. When this standard states "addition", "modification" or "replacement", the relevant text of Part 1 is to be adapted accordingly.

NOTE 1 The following numbering system is used:

- subclauses, tables and figures that are numbered starting from 101 are additional to those in Part 1;
- unless notes are in a new subclause or involve notes in Part 1, they are numbered starting from 101, including those in a replaced clause or subclause;
- additional annexes are lettered AA, BB, etc.;
- subclauses, notes and annexes that are additional to those in the IEC standard are prefixed with the letter Z.

NOTE 2 The following print types are used:

- requirements: in roman type;
- *test specifications: in italic type;*
- notes: in small roman type.

Words in **bold** in the text are defined in Clause 3. When a definition concerns an adjective, the adjective and the associated noun are also in bold.

There are no special national conditions causing a deviation from this European Standard, other than those listed in Annex ZA to EN 60335-1.

There are no national deviations from this European Standard, other than those listed in Annex ZB to EN 60335-1.

Introduction

p Add:

An investigation by CENELEC TC 61 has shown that all risks from products within the scope of this standard are fully covered by the Low Voltage Directive, 2006/95/EC. For products having mechanical moving parts, a risk assessment in accordance with the Machinery Directive, 2006/42/EC, has shown that the risks are mainly of electrical origin and consequently this directive is not applicable. However, the relevant essential safety requirements of the Machinery Directive are covered by this standard together with the principal objectives of the Low Voltage Directive.

Endorsement notice

The text of the International Standard IEC 60335-2-2:2009 was approved by CENELEC as a European Standard without any modification.

Foreword to amendment A11

This document (EN 60335-2-2:2010/A11:2012) has been prepared by CLC/TC 61 "Safety of household and similar electrical appliances".

The following dates are fixed:

- latest date by which this document has to be implemented at national level by publication of an identical national standard or by endorsement (dop) 2013-07-09
- latest date by which the national standards conflicting with this document have to be withdrawn (dow) 2015-02-01

Attention is drawn to the possibility that some of the elements of this document may be the subject of patent rights. CENELEC [and/or CEN] shall not be held responsible for identifying any or all such patent rights.

This amendment supplements or modifies the corresponding clauses of EN 60335-1:2012 and EN 60335-2-2:2010.

This standard covers the Principle Elements of the Safety Objectives for Electrical Equipment Designed for Use within Certain Voltage Limits (LVD - 2006/95/EC).

Bibliography

p Add the following notes to the standards mentioned:

- | | | |
|----------------|------|-------------------------------|
| IEC 60335-2-69 | NOTE | Harmonized as EN 60335-2-69. |
| ISO 13732-1 | NOTE | Harmonized as EN ISO 13732-1. |
-

Foreword to amendment A1

The text of document 61/4446/FDIS, future amendment 1 to edition 6 of IEC 60335-2-2, prepared by IEC/TC 61 "Safety of household and similar electrical appliances" was submitted to the IEC-CENELEC parallel vote and approved by CENELEC as EN 60335-2-2:2010/A1:2013.

The following dates are fixed:

- latest date by which the document has to be implemented at national level by publication of an identical national standard or by endorsement (dop) 2013-09-22
- latest date by which the national standards conflicting with the document have to be withdrawn (dow) 2015-12-20

Attention is drawn to the possibility that some of the elements of this document may be the subject of patent rights. CENELEC [and/or CEN] shall not be held responsible for identifying any or all such patent rights.

This standard covers the Principle Elements of the Safety Objectives for Electrical Equipment Designed for Use within Certain Voltage Limits (LVD - 2006/95/EC).

Endorsement notice

The text of the International Standard IEC 60335-2-2:2009/A1:2012 was approved by CENELEC as a European Standard without any modification.

p Add:

Annex ZC
(normative)

**Normative references to international publications
with their corresponding European publications**

Addition:

<u>Publication</u>	<u>Year</u>	<u>Title</u>	<u>EN/HD</u>	<u>Year</u>
IEC 60312	-	Vacuum cleaners for household use - Methods of measuring the performance	EN 60312	-
ISO 6344-2	-	Coated abrasives - Grain size analysis - Part 2: Determination of grain size distribution of Abrasives P12 to P220	-	-

<http://www.china-gauges.com/>

CONTENTS

INTRODUCTION.....	9
1 Scope.....	9
2 Normative references.....	10
3 A1 Terms and definitions A1	10
4 General requirement.....	11
5 General conditions for the tests.....	11
6 Classification.....	12
7 Marking and instructions.....	12
8 Protection against access to live parts.....	14
9 Starting of motor-operated appliances.....	14
10 Power input and current.....	14
11 Heating.....	14
12 Void.....	15
13 Leakage current and electric strength at operating temperature.....	15
14 Transient overvoltages.....	15
15 Moisture resistance.....	15
16 Leakage current and electric strength.....	17
17 Overload protection of transformers and associated circuits.....	17
18 Endurance.....	17
19 Abnormal operation.....	17
20 Stability and mechanical hazards.....	18
21 Mechanical strength.....	19
22 Construction.....	21
23 Internal wiring.....	22
24 Components.....	22
25 Supply connection and external flexible cords.....	22
26 Terminals for external conductors.....	23
27 Provision for earthing.....	23
28 Screws and connections.....	23
29 Clearances, creepage distances and solid insulation.....	23
30 Resistance to heat and fire.....	23
31 Resistance to rusting.....	23
32 Radiation, toxicity and similar hazards.....	23
Annexes.....	27
Annex B (normative) Appliances powered by rechargeable batteries.....	27
Annex C (normative) Ageing test on motors.....	29
A1 Annex R (normative) Software evaluation A1	30
Bibliography.....	30
Figure 101 – Apparatus for testing the abrasion resistance of current-carrying hoses.....	24
Figure 102 – Apparatus for testing the resistance to flexing of current-carrying hoses.....	25

Figure 103 – Configuration of the hose for the freezing treatment 26
Figure 104 – Flexing positions for the hose after removal from the freezing cabinet..... 26

<http://www.china-gauges.com/>

INTRODUCTION

It has been assumed in the drafting of this International Standard that the execution of its provisions is entrusted to appropriately qualified and experienced persons.

This standard recognizes the internationally accepted level of protection against hazards such as electrical, mechanical, thermal, fire and radiation of appliances when operated as in normal use taking into account the manufacturer's instructions. It also covers abnormal situations that can be expected in practice and takes into account the way in which electromagnetic phenomena can affect the safe operation of appliances.

This standard takes into account the requirements of IEC 60364 as far as possible so that there is compatibility with the wiring rules when the appliance is connected to the supply mains. However, national wiring rules may differ.

If an appliance within the scope of this standard also incorporates functions that are covered by another part 2 of IEC 60335, the relevant part 2 is applied to each function separately, as far as is reasonable. If applicable, the influence of one function on the other is taken into account.

When a part 2 standard does not include additional requirements to cover hazards dealt with in part 1, part 1 applies.

NOTE 1 This means that the technical committees responsible for the part 2 standards have determined that it is not necessary to specify particular requirements for the appliance in question over and above the general requirements.

This standard is a product family standard dealing with the safety of appliances and takes precedence over horizontal and generic standards covering the same subject.

NOTE 2 Horizontal and generic standards covering a hazard are not applicable since they have been taken into consideration when developing the general and particular requirements for the IEC 60335 series of standards. For example, in the case of temperature requirements for surfaces on many appliances, generic standards, such as ISO 13732-1 for hot surfaces, are not applicable in addition to part 1 or part 2 standards.

An appliance that complies with the text of this standard will not necessarily be considered to comply with the safety principles of the standard if, when examined and tested, it is found to have other features that impair the level of safety covered by these requirements.

An appliance employing materials or having forms of construction differing from those detailed in the requirements of this standard may be examined and tested according to the intent of the requirements and, if found to be substantially equivalent, may be considered to comply with the standard.

HOUSEHOLD AND SIMILAR ELECTRICAL APPLIANCES – SAFETY –

Part 2-2: Particular requirements for vacuum cleaners and water-suction cleaning appliances

1 Scope

Ⓒ11 This clause of Part 1 is replaced by the following:

This European Standard deals with the safety of electric vacuum cleaners and water suction cleaning appliances for household and similar purposes, including vacuum cleaners for animal grooming, their **rated voltage** being not more than 250 V. It also applies to centrally-sited vacuum cleaners and automatic battery-powered cleaners.

This European Standard also applies to motorized cleaning heads and current-carrying hoses associated with a particular vacuum cleaner.

Appliances intended to be used by laymen in shops and other premises for normal housekeeping purposes, are within the scope of this European Standard.

NOTE Z101 Examples of appliance for household environment are appliances for typical housekeeping functions used in the household environment that may also be used by non-expert users for typical housekeeping functions:

- in shops and other similar working environments;
- in farm houses;
- by clients in hotels, motels and other residential type environments;
- in bed and breakfast type environments.

NOTE Z102 Household environments include the dwelling and its associated buildings, the garden, etc.

As far as is practicable, this European Standard deals with the common hazards presented by appliances that are encountered by all persons in household and similar environments.

However, in general, it does not take into account

- **children** playing with the appliance,
- the use of the appliance by **very young children**,
- the use of the appliance by **young children** without supervision.

It is recognized that **very vulnerable people** may have needs beyond the level addressed in this European Standard.

This European Standard does not apply to

- appliances intended exclusively for industrial and commercial purposes,
- appliances intended to be used in locations where special conditions prevail, such as the presence of a corrosive or explosive atmosphere (dust, vapour or gas),
- wet and dry vacuum cleaners, including power brush, for commercial use (EN 60335-2-69).

NOTE Z103 Attention is drawn to the fact that

- for appliances intended to be used in vehicles or on board ships or aircraft, additional requirements may be necessary,
- in many countries additional requirements are specified by the national health authorities, the national authorities responsible for the protection of labour, the national water supply authorities and similar authorities. Ⓒ11

2 Normative references

This clause of Part 1 is applicable except as follows.

Addition:

IEC 60312, *Vacuum cleaners for household use – Methods of measuring the performance*

ISO 6344-2, *Coated abrasives – Grain size analysis – Part 2: Determination of grain size distribution of macrogrits P12 to P220*

3 ^{A1} Terms and definitions ^{A1}

This clause of Part 1 is applicable except as follows.

3.1.4 *Addition:*

NOTE 101 For appliances incorporating a **booster setting**, the **rated power input** corresponds to the operation of the appliance without the **booster setting** being used.

3.1.9 *Replacement:*

normal operation

operation of the appliance under the following conditions:

the appliance is supplied at **rated voltage** and operated continuously with the air inlet adjusted to give a power input P_m after 20 s

Three minutes later a final adjustment of the air inlet is made, if necessary.

P_m is calculated from the formula

$$P_m = 0,5 (P_f + P_i)$$

where

P_f is the power input in watts, after 3 min of operation with the air inlet unobstructed. Any device that ensures a flow of air to cool the motor in the event of a blockage of the main air inlet is allowed to operate;

P_i is the power input in watts, after a further 20 s of operation with the air inlet blocked. Any device that is adjustable without the aid of a **tool**, and which ensures a flow of air to cool the motor in the event of a blockage of a main air inlet, is rendered inoperative.

If the appliance is marked with a **rated voltage range**, it is supplied at the mean value of the range if the difference between the limits of the range does not exceed 10 % of the mean value. If the difference exceeds 10 %, the supply voltage is the upper value of the range.

The measurements are made with the appliance fitted with a clean dust bag and filter, any water collection container being empty. If the appliance is intended to be used only with a hose, detachable nozzles and tubes are removed and the hose is laid out straight. If the appliance is provided with a hose as an accessory, it is operated without the hose.

Rotating brushes and similar devices are in operation but not in contact with any surface. **Motorized cleaning heads** are connected by means of the hose or tube and are in operation but not in contact with any surface.

Appliance outlets for other accessories are loaded with a resistive load in accordance with the marking.

Automatic battery-powered cleaners are operated with a clean dust bag or filter on the carpet defined in IEC 60312. A frame of 1,5 m by 1,5 m is used on the carpet to limit the area of action. The air inlet is unobstructed.

3.101

water-suction cleaning appliance

appliance for aspirating an aqueous solution that may contain cleaning detergent

3.102

booster setting

position of a control resulting in a temporary higher power input that is automatically reduced to the power input value when the setting is not used

3.103

centrally-sited vacuum cleaner

vacuum cleaner that is connected to a ducting system installed in the building

NOTE During use, the nozzle and its associated hose are connected to one of the suction inlets of the ducting system.

3.104

motorized cleaning head

accessory containing a motor that is supplied from the vacuum cleaner and which is attached to the end of a hose or tube

3.105

automatic battery-powered cleaner

automatic vacuum cleaner that operates without human control only within a defined perimeter, within a pre-programmed area or in an area self-controlled by the appliance

The cleaner consists of the mobile part and may have a **docking station**.

3.106

docking station

unit that may provide

- manual or automatic battery charging facilities,
- dust removal,
- data processing facility, and
- suction for the mobile part

NOTE A **docking station** is also known as a base unit.

4 General requirement

This clause of Part 1 is applicable.

5 General conditions for the tests

This clause of Part 1 is applicable except as follows.

5.2 Addition:

A new hose is used for each of the tests of 21.101 to 21.105.

5.101 *Current-carrying hoses operating at **safety extra-low voltage** are not subjected to the tests of 21.101 to 21.105.*

6 Classification

This clause of Part 1 is applicable except as follows.

6.1 *Modification:*

Vacuum cleaners and **water-suction cleaning appliances** shall be **class I**, **class II** or **class III**.

Vacuum cleaners for animal grooming shall be **class II** or **class III**.

Vacuum cleaners may be **class 0** provided that their **rated voltage** does not exceed 150 V.

Stationary parts of **automatic battery-powered cleaners** may be **class 0** if the **rated voltage** does not exceed 150 V.

6.2 *Addition:*

Vacuum cleaners for animal grooming and **water-suction cleaning appliances** shall be at least IPX4.

7 Marking and instructions

This clause of Part 1 is applicable except as follows.

7.1 *Addition:*

The appliance shall be marked with the sum of its **rated power input** and the maximum load of the appliance outlet in watts (if applicable).

7.6 *Addition:*

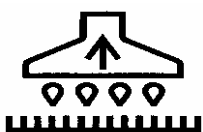

[symbol IEC 60417-5935 (2002-10)]

motorized cleaning head for
water suction cleaning

7.12 *Addition:*

C11 7.12 Instructions for use shall be provided with the appliance so that the appliance can be used safely.

NOTE Instructions for use may be marked on the appliance as long as they are visible in normal use.

It is necessary to take precautions during **user maintenance**, appropriate details shall be given. **C11**

Ⓒ11 The instructions shall state the substance of the following:

This appliance can be used by children aged from 8 years and above and persons with reduced physical, sensory or mental capabilities or lack of experience and knowledge if they have been given supervision or instruction concerning use of the appliance in a safe way and understand the hazards involved. Children shall not play with the appliance. Cleaning and user maintenance shall not be made by children without supervision.

If a vacuum cleaner can be equipped with a **hand-held accessory** with rotating parts a warning has to be given concerning entrapment.

The instructions for appliances having a current-carrying hose operating at other than **safety extra-low voltage** shall include the substance of the following:

CAUTION: This hose contains electrical connections:

- do not use to suck up water (for vacuum cleaners only);
- do not immerse in water for cleaning;
- the hose should be checked regularly and must not be used if damaged.

The instructions for appliances having a part of **class III construction** supplied from a **detachable power supply unit** shall state that the appliance is only to be used with the power supply unit provided with the appliance.

The instructions for **class III appliances** shall state that it must only be supplied at safety extra low voltage corresponding to the marking on the appliance. This instruction is not necessary for battery-operated appliances if the battery is a primary battery or secondary battery charged outside of the appliance.

The instructions for vacuum cleaners incorporating rotating brushes or similar devices, and **water-suction cleaning appliances**, shall state that the plug must be removed from the socket-outlet before cleaning or maintaining the appliance.

If symbol 5935 of IEC 60417 is used, its meaning shall be explained.

Compliance is checked by inspection. Ⓒ11

7.14 Addition:

The height of symbol IEC 60417-5935 (2002-10) shall be at least 15 mm.

Compliance is checked by measurement.

7.101 Motorized cleaning heads shall be marked with

- **rated voltage** or **rated voltage range** in volts;
- **rated power input** in watts;
- name, trade mark or identification mark of the manufacturer or responsible vendor;
- model or type reference.

Motorized cleaning heads for water-suction cleaning appliances, except those of **class III construction** having a **working voltage** up to 24 V, shall be marked with symbol IEC 60417-5935 (2002-10).

NOTE This symbol is an information sign and, except for the colours, the rules of ISO 3864-1 apply.

Compliance is checked by inspection.

7.102 Appliance outlets for accessories shall be marked with the maximum load in watts.

NOTE This marking may be on the appliance close to the appliance outlet.

Compliance is checked by inspection.

8 Protection against access to live parts

This clause of Part 1 is applicable except as follows.

8.1.1 Addition:

If the instructions state that a part is to be removed when replacing an fan or a drive belt, and a **tool** is required for its removal, the part is not considered to be a **detachable part** provided that

- an instruction to disconnect the appliance from the supply before opening is marked on the cover or is visible during its removal, and
- after removal of the cover, access to **live parts** is prevented by at least **basic insulation**.

9 Starting of motor-operated appliances

This clause of Part 1 is not applicable.

10 Power input and current

This clause of Part 1 is applicable except as follows.

10.1 Addition:

*The power input of **motorized cleaning heads** is measured separately.*

NOTE 101 Appliance outlets are not loaded when measuring the **rated power input**.

Booster settings are not used during these measurements.

11 Heating

This clause of Part 1 is applicable except as follows.

11.3 Addition:

NOTE 101 When measuring the power input to ensure that the appliance has been correctly reassembled, the power input P_1 with the air-inlet blocked is measured.

11.5 Addition:

Booster settings are activated as often as allowed by the construction.

Docking stations of automatic battery-powered cleaners are operated at 0,94 or 1,06 times **rated voltage**, whichever is the most unfavourable.

*If a suction mode is incorporated in **docking stations of automatic battery-powered cleaners**, the test conditions of 3.1.9 are applied.*

11.7 Addition:

Appliances are operated until steady conditions are established.

Appliances incorporating an automatic cord reel are operated with one-third of the total length of the cord unreeled for 30 min, after which the cord is completely unreeled.

11.8 Modification:

Replace the first paragraph of Part 1 by the following: "During the test, the temperature rises are monitored continuously and shall not exceed the values shown in Table 3 and Table Z101".

In Table 3 delete the row "External enclosure of **motor-operated appliances**, except hand tools held in normal use" and the corresponding footnotes.

Add the following Table Z101.

Table Z101 – Maximum temperature rises for external surfaces under normal operating conditions

Surface ^a	Temperature rise of external surfaces K	
	Surfaces of appliances situated up to 850 mm above the floor after installation and portable appliances ^d	Surfaces of appliances situated more than 850 mm above the floor after installation (e.g. central vacuum cleaners) ^e
Bare metal	40	45
Coated metal ^b	45	55
Glass and ceramic	55	60
Plastic and plastic coating > 0,3 mm ^c	60	65

^a When the thickness of the plastic coating does not exceed 0,3 mm, the temperature rise limits of the coated metal or of glass and ceramic material apply.

^b Metal is considered coated when a coating having a minimum thickness of 80 µm made by enamel or non substantially plastic coating is used.

^c The temperature rise limit of plastic also applies for plastic material having a metal finish of thickness less than 0,1 mm.

^d For air outlets the above values can be increased by 10 K.

^e For air outlets the above values can be increased by 5 K.

12 Void

13 Leakage current and electric strength at operating temperature

This clause of Part 1 is applicable except as follows.

13.1 Addition:

NOTE 101 **Booster settings** are not used.

14 Transient overvoltages

This clause of Part 1 is applicable.

15 Moisture resistance

This clause of Part 1 is applicable except as follows.

15.2 Replacement:

Appliances having a liquid container shall be constructed so that spillage of liquid due to overfilling, and due to overturning of appliances liable to be overturned in normal use, does not affect their electrical insulation.

Compliance is checked by the following test.

The liquid container is filled with water to half the level indicated in the instructions. The appliance is placed on a support inclined at an angle of 15° to the horizontal. A force of 180 N is applied to the top of the appliance in the most unfavourable horizontal direction. If the appliance overturns, it is considered to be liable to be overturned in normal use.

Appliances with **type X attachment**, except those having a specially prepared cord, are fitted with the lightest permissible type of flexible cord of the smallest cross-sectional area specified in Table 13.

Appliances incorporating an appliance inlet are tested with or without an appropriate connector in position, whichever is more unfavourable.

Liquid containers that are filled by hand are completely filled with water containing approximately 1 % NaCl, and a further quantity, equal to 15 % of the capacity of the container or 0,25 l, whichever is the greater, is poured in steadily over a period of 1 min.

Containers of **hand-held appliances** and other appliances liable to be overturned in normal use are completely filled, the cover being closed. The appliance is then overturned and left in that position for 5 min, unless it returns automatically to its normal position of use.

Nozzles and **motorized cleaning heads of water-suction cleaning appliances** are placed in a container, the base of which is level with the surface supporting the appliance. The container is filled with a detergent solution to a level of 5 mm above its base, this level being maintained throughout the test. The solution consists of 20 g of NaCl and 1 ml of a solution of 28 % by mass of dodecyl sodium sulphate in each 8 l of water.

The appliance is operated until its liquid container is completely full and for a further 5 min.

NOTE 101 The solution is to be stored in a cool atmosphere and used within seven days of its preparation.

NOTE 102 The chemical designation of dodecyl sodium sulphate is $C_{12}H_{25}NaSO_4$.

After each of these tests, the appliance shall withstand the electric strength test of 16.3.

Inspection shall show that there is no trace of liquid on insulation that could result in a reduction of **clearances** or **creepage distances** below the values specified in Clause 29.

15.101 Motorized cleaning heads of water-suction cleaning appliances shall be resistant to liquids that may come into contact with them.

Compliance is checked by the following tests.

The **motorized cleaning head** is subjected to an impact test as described in IEC 60068-2-75, the value of the impact being 2 J. The **motorized cleaning head** is rigidly supported and three blows are applied to every point of the enclosure that is likely to be weak.

It is then subjected to the free-fall test procedure 1 of IEC 60068-2-32. It is dropped 4 000 times from a height of 100 mm onto a steel plate having a thickness of not less than 15 mm. It is dropped

- 1 000 times on its right side;
- 1 000 times on its left side;
- 1 000 times on its front face;
- 1 000 times on its cleaning surface.

The **motorized cleaning head** is then subjected to the test described in 14.2.7 of IEC 60529, the water containing approximately 1 % NaCl.

The **motorized cleaning head** shall then withstand the electric strength test of 16.3, the voltage being applied between the **live parts** and the solution. Inspection shall show that there is no trace of saline solution on insulation that could result in a reduction of **clearances** or **creepage distances** below the values specified in Clause 29.

NOTE The test is not carried out on **motorized cleaning heads** of **class III construction** having a **working voltage** up to 24 V.

16 Leakage current and electric strength

This clause of Part 1 is applicable except as follows.

16.3 Addition:

Current-carrying hoses, except for their electrical connections, are immersed for 1 h in water containing approximately 1 % NaCl, at a temperature of 20 °C ± 5 °C. While the hose is still immersed, a voltage of 2 000 V is applied for 5 min between each conductor and all the other conductors connected together. A voltage of 3 000 V is then applied for 1 min between all the conductors and the saline solution.

17 Overload protection of transformers and associated circuits

This clause of Part 1 is applicable.

18 Endurance

This clause of Part 1 is not applicable.

19 Abnormal operation

This clause of Part 1 is applicable except as follows.

19.1 Addition:

*The test of 19.7 is only carried out on **motorized cleaning heads** and separate fan motors of **centrally-sited vacuum cleaners**.*

***Water-suction cleaning appliances** having a valve are also subjected to the test of 19.101.*

*Appliances incorporating a **booster setting** that is not deactivated electronically are also subjected to the test of 19.102.*

Centrally-sited vacuum cleaners are also subjected to the tests of 19.103, and 19.104 if applicable.

19.7 Addition:

Motorized cleaning heads are tested with the rotating brush or similar device locked for 30 s.

Separate fan motors of **centrally-sited vacuum cleaners** are operated until steady conditions are reached.

19.9 Replacement:

Docking stations of **automatic battery-powered cleaners** incorporating a suction mode are tested at **rated voltage** with the air inlet fully blocked until steady conditions are established.

The temperatures of the windings shall not exceed the values specified in Table 8.

19.10 Replacement:

Appliances incorporating series motors are supplied at 1,3 times **rated voltage** and operated for 30 s with the air inlet blocked, rotating brushes and similar devices being removed.

After this test, the safety of the appliance shall not have been impaired, in particular windings and connections shall not have worked loose.

19.101 Water-suction cleaning appliances, the liquid container of which incorporates a valve or other overflow prevention device, are supplied at **rated voltage**. The appliance is operated with the nozzle placed in a trough containing water and with the valve or overflow prevention-device held open or otherwise rendered inoperative. The test is terminated 30 s after water starts to flow out of the appliance.

NOTE If the appliance incorporates more than one overflow prevention device, these are rendered inoperative in turn.

19.102 The deactivating means of the **booster setting** is rendered inoperative and the appliance is operated under the conditions specified in Clause 11 using the **booster setting**.

19.103 Centrally-sited vacuum cleaners are supplied at **rated voltage** and operated with the inlet for the suction hose open and then closed.

The temperatures of the windings shall not exceed the values specified in 19.9.

19.104 Centrally-sited vacuum cleaners with separate ventilation for the motor are supplied at **rated voltage** and operated with the airflow through the motor blocked.

20 Stability and mechanical hazards

This clause of Part 1 is applicable except as follows.

20.1 Addition:

NOTE 101 **Motorized cleaning heads** are not subjected to this test.

20.2 Addition:

NOTE 101 The requirement regarding moving parts does not apply to rotating brushes and similar devices. It does not apply to parts that become accessible when changing accessories and only move when the brush or similar device is in operation.

- Ⓒ11) **20.Z101** Driven parts of an appliance shall not become accessible if the appliance is switched on by overturning.

The appliance is fully assembled as in normal operation without any parts removed. The appliance connected to the mains is overturned in the most unfavourable position. If the appliance is activated as consequence of overturning, hazardous moving parts shall not be accessible according to 20.2.

The test is made in the most unfavourable orientation.

- 20.Z102** Inadvertent access to hazardous rotating brushes and similar devices during **normal operation** shall be prevented, so far as is reasonably practicable.

Appliances are fully assembled as in normal operation without any parts removed. Compliance is checked by using the foot probe as illustrated in Figure Z101. The appliance is placed on a hard flat surface, being in the normal operating position. Height adjustment components such as rollers or wheels are adjusted to the most unfavourable position. The base of the foot probe is held horizontally and applied to any point on the periphery of the cleaner in contact with the floor without appreciable force. The test is conducted under static conditions. The probe shall not touch rotating parts. Ⓒ11)

21 Mechanical strength

- Ⓒ11) **21.1** Modification:

The appliance is rigidly supported and three blows, having an impact energy of 1,0 J, are applied to every point of the enclosure that is likely to be weak. Ⓒ11)

This clause of Part 1 is applicable except as follows.

- 21.101** Current-carrying hoses shall be resistant to crushing.

Compliance is checked by the following test.

The hose is placed between two parallel steel plates each having a length of 100 mm, a width of 50 mm and the edges of the longer sides rounded with a radius of 1 mm. The axis of the hose is positioned at right angles to the longer sides of the plates. The plates are placed at a distance of approximately 350 mm from one end of the hose.

The steel plates are pressed together at a rate of 50 mm/min \pm 5 mm/min until the applied force is 1,5 kN. The force is then released and the electric strength test of 16.3 is carried out between the conductors connected together and the saline solution.

- 21.102** Current-carrying hoses shall be resistant to abrasion.

Compliance is checked by the following test.

One end of the hose is attached to the connecting rod of the crank mechanism shown in Figure 101. The crank rotates at 30 r/min resulting in the end of the hose moving horizontally backwards and forwards over a distance of 300 mm.

The hose is supported by a rotating smooth roller over which a belt of abrasive cloth moves at a speed of 0,1 m/min. The abrasive is corundum grit size P 100, as specified in ISO 6344-2. A mass of 1 kg is suspended from the other end of the hose, which is guided to avoid rotation. In the lowest position, the mass has a maximum distance of 600 mm from the centre of the roller.

The test is carried out for 100 revolutions of the crank.

After the test, **basic insulation** shall not be exposed, and the electric strength test of 16.3 is carried out between the conductors connected together and the saline solution.

21.103 Current-carrying hoses shall be resistant to flexing.

Compliance is checked by the following test.

The end of the hose intended to be connected to the **motorized cleaning head** is attached to the pivoting arm of the test equipment shown in Figure 102. The distance between the pivot axis of the arm and the point where the hose enters the rigid part is $300 \text{ mm} \pm 5 \text{ mm}$. The arm can be raised from the horizontal position by an angle of $40^\circ \pm 1^\circ$. A mass of 5 kg is suspended from the other end of the hose or from a convenient point along the hose so that when the arm is in the horizontal position the mass is supported and there is no tension on the hose.

NOTE 1 It may be necessary to reposition the mass during the test.

The mass slides against an inclined plate so that the maximum deflection of the hose is 3° . The arm is raised and lowered by means of a crank that rotates at a speed of $10 \text{ r/min} \pm 1 \text{ r/min}$.

The test is carried out for 2 500 revolutions of the crank after which the fixed end of the hose is turned through 90° and the test continued for a further 2 500 revolutions. The test is repeated in each of the other two 90° positions.

NOTE 2 If the hose ruptures before 10 000 revolutions of the crank, the flexing is terminated.

After the test, the hose shall withstand the electric strength test of 16.3.

21.104 Current-carrying hoses shall be resistant to torsion.

Compliance is checked by the following test.

One end of the hose is held in a horizontal position with the remainder of the hose freely suspended. The free end is rotated in cycles, each cycle consisting of five turns in one direction and five turns in the opposite direction, at a rate of 10 turns per minute.

The test is carried out for 2 000 cycles.

After the test, the hose shall withstand the electric strength test of 16.3 and shall not be damaged to such an extent that compliance with this standard is impaired.

21.105 Current-carrying hoses shall be resistant to cold conditions.

Compliance is checked by the following test.

A 600 mm length of hose is bent as shown in Figure 103 and the ends are tied together over a length of 25 mm. The hose is then placed for 2 h in a cabinet having a temperature of $-15^\circ\text{C} \pm 2^\circ\text{C}$. Immediately after, the hose is removed from the cabinet it is flexed three times, as shown in Figure 104, at a rate of one flexing per second.

The test is carried out three times.

There shall be no cracks or breaks in the hose and it shall withstand the electric strength test of 16.3.

NOTE Any discoloration is neglected.

C11 21.Z101 **Hand-held appliances** are subjected to the following test:

The appliance is put on an horizontal surface 700 mm above a rigidly supported hardwood board and operated while supplied at rated voltage until steady state conditions are reached.

It is then allowed to drop freely. The test is carried out five times, the appliance being held in different positions likely to occur.

The appliance shall not be damaged to such an extent that compliance with this European Standard is impaired. In particular, the appliance shall not emit flames or molten metal and the requirements of Clauses 8 and 29 shall be fulfilled.

22 Construction

This clause of Part 1 is applicable except as follows.

22.32 Addition:

Vacuum cleaners shall be constructed so that the internal parts of the motors and electrical connections are not subjected to deposition of dust due to the passage of air.

NOTE 101 This requirement is met if the air passes through the dust bag before it passes through the motor.

NOTE 102 For **water-suction cleaning appliances**, compliance with the requirement concerning protection against deposition of pollution has been adequately checked by the test of 15.2.

22.101 Motorized cleaning heads for use with appliances that have a water-suction cleaning mode, except those of class III construction having a working voltage up to 24 V, shall be motorized cleaning heads for water-suction cleaning appliances.

*Compliance is checked by inspection of the marking and the tests for **motorized cleaning heads for water-suction cleaning appliances**.*

C11 22.Z101 Hinged handles of vacuum cleaners intended to be free standing shall require a specific action to operate them, such as a lever, the handle release mechanism or similar.

Compliance is checked by inspection.

22.Z102 **Supply cords** of appliances shall not be damaged by the appliance running over them.

The functional openings of power rotating brushes, driven by the main suction motor, shall not exceed 120 mm along the major dimension of the opening.

Compliance is checked by inspection and measurement. **C11**

23 Internal wiring

This clause of Part 1 is applicable.

24 Components

This clause of Part 1 is applicable except as follows.

24.1.3 Addition:

Switches incorporated in vacuum cleaners, other than those for household use only, are tested for 50 000 cycles of operation.

25 Supply connection and external flexible cords

This clause of Part 1 is applicable except as follows.

25.1 Addition:

Vacuum cleaners for animal grooming and **water-suction cleaning appliances** shall not incorporate an appliance inlet.

25.7 Modification:

Supply cords shall be not lighter than the following:

- for **hand-held appliances** having a mass not exceeding 1,5 kg when fitted with the heaviest accessory, but excluding the **supply cord**,
 - if rubber insulated, ordinary tough rubber sheathed flexible cord (code designation 60245 IEC 53);
 - if polyvinyl chloride insulated, light polyvinyl chloride sheathed flexible cord (code designation 60227 IEC 52);
- for appliances for animal grooming,
 - ordinary polychloroprene sheathed flexible cord (code designation 60245 IEC 57);
 - if polyvinyl chloride insulated, flat twin flexible cord (code designation 60227 IEC 42);
- for other appliances,
 - if rubber insulated, ordinary tough rubber sheathed flexible cord (code designation 60245 IEC 53);
 - if polyvinyl chloride insulated, ordinary polyvinyl chloride sheathed flexible cord (code designation 60227 IEC 53).

25.23 Addition:

Live conductors in a flexible hose shall have an insulation and sheath thickness at least equivalent to that specified for a 60227 IEC 52 cord of $2 \times 0,75 \text{ mm}^2$.

NOTE 101 The conductors used may consist of copper-plated steel wires.

26 Terminals for external conductors

This clause of Part 1 is applicable.

27 Provision for earthing

This clause of Part 1 is applicable.

28 Screws and connections

This clause of Part 1 is applicable.

29 Clearances, creepage distances and solid insulation

This clause of Part 1 is applicable.

30 Resistance to heat and fire

This clause of Part 1 is applicable except as follows.

30.2 Addition:

For centrally-sited vacuum cleaners, 30.2.3 is applicable. For other appliances, 30.2.2 is applicable.

31 Resistance to rusting

This clause of Part 1 is applicable.

32 Radiation, toxicity and similar hazards

This clause of Part 1 is applicable.

<http://www.china-gauges.com/>

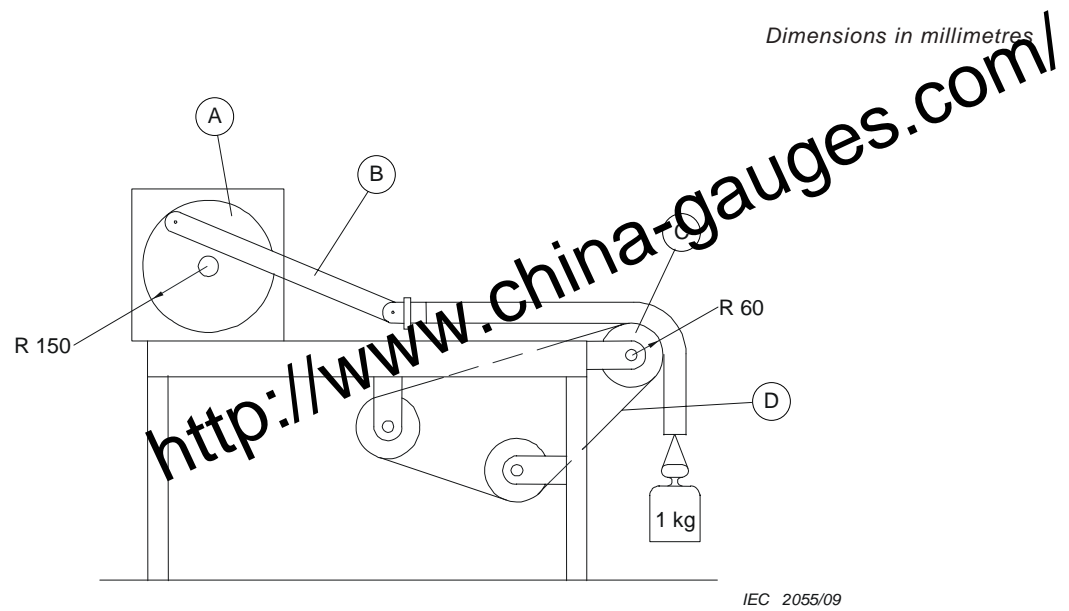

Key

- A crank mechanism
- B connecting rod
- C roller, diameter 120 mm
- D abrasive cloth belt

Figure 101 – Apparatus for testing the abrasion resistance of current-carrying hoses

Dimensions in millimetres

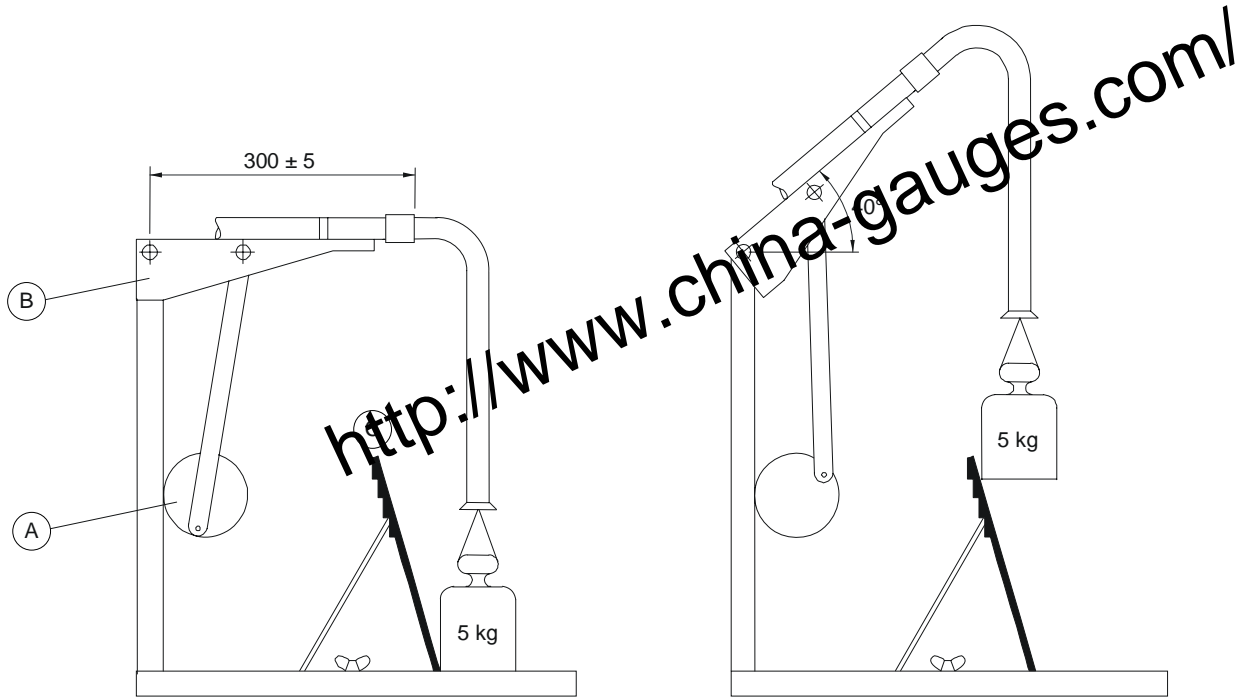

IEC 2056/09

Key

- A crank mechanism
- B arm
- C inclined plane

Figure 102 – Apparatus for testing the resistance to flexing of current-carrying hoses

Dimensions in millimetres

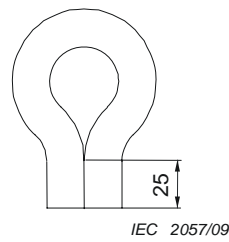

Figure 103 – Configuration of the hose for the freezing treatment

In the intermediate position



Position of the hose at start
and finish of each flexing

IEC 2058/09

Figure 104 – Flexing positions for the hose after removal from the freezing cabinet

C11

Dimensions in millimetres

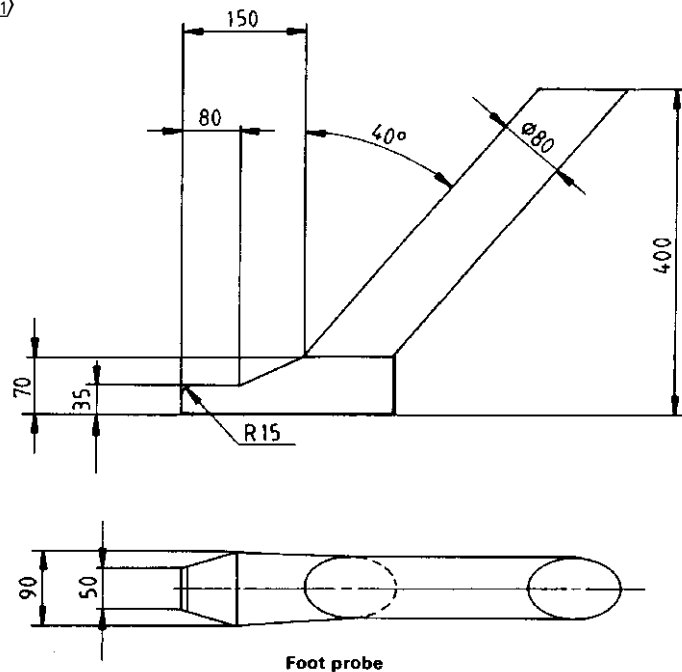

Figure Z101 – Foot probe C11

Annexes

The annexes of Part 1 are applicable except as follows.

Annex B (normative)

Appliances powered by rechargeable batteries

This annex of Part 1 is applicable except as follows.

NOTE Additional subclauses in this annex are numbered starting with 201.

6 Classification

6.1 Mobile parts of **automatic battery-powered cleaners** shall be **class II** or **class III**.

7 Marking and instructions

7.1 Addition:

The mobile part of an **automatic battery-powered cleaner** shall be marked with the

- name, trademark or identification mark of the manufacturer or responsible vendor;
- the model or type reference of the **docking station** with which the mobile part is intended to be used.

7.12 Addition:

Automatic battery-operated cleaners shall also be provided with cautionary instructions for room preparation and constant care.

11.7 Addition:

*For mobile parts of **automatic battery-powered cleaners**, the test ends when the cleaning operation is stopped due to the discharging of the battery.*

19 Abnormal operation

19.1 Addition:

*Mobile parts of **automatic battery-powered cleaners** are subjected to the test of 19.7 while they are being supplied by their battery.*

19.7 *On mobile parts of **automatic battery-powered cleaners**, the rotor is locked.*

21 Mechanical strength

21.201 Mobile parts of **automatic battery-powered cleaners** shall have sufficient mechanical strength.

Compliance is checked by the following test.

An evenly distributed load of 60 kg is placed on top of the mobile part for 60 s. During this test, no short circuit shall occur. After the test, there shall be no visible damage that could impair compliance with this standard.

22 Construction

22.40 Mobile parts of **automatic battery-powered cleaners** shall be fitted with a switch to turn the appliance off.

A1 Compliance is checked by inspection.

If compliance relies on the operation of an **electronic circuit**, the electromagnetic phenomena tests of Subclause 19.11.4.1 and 19.11.4.2 have to be applied. During the tests, the motor which moves the mobile part shall not start. **A1**

22.201 Mobile parts of **automatic battery-powered cleaners** shall be equipped with

- a device to stop movement within 1 s of accessible hazardous moving parts when they lose contact with the surface being cleaned, and
- A1** – a device to protect the appliance from dropping off the cleaning surface (e.g. stairways, etc.). When the mobile part senses that it has reached a critical edge, it shall
 - stop; or
 - reverse and move away from the edge of the cleaning surface and then continue to operate normally. **A1**

Compliance is checked by inspection and test.

A1 NOTE The test can be carried out on a testing bed with rollers.

If compliance relies on the operation of an **electronic circuit**, the test is repeated under the following conditions applied separately:

- the fault conditions in a) to g) of 19.11.2 applied one at a time to the **electronic circuit**;
- the electromagnetic phenomena test of 19.11.4.1 and 19.11.4.2 applied to the appliance.

If the **electronic circuit** is programmable, the software shall contain measures to control the fault/error conditions specified in Table R.1 and is evaluated in accordance with the relevant requirements of Annex R. **A1**

22.202 When operating on a sloping surface, the speed of the mobile part shall not be excessive.

Compliance is checked by the following test.

The speed of the mobile part is measured during the test of Clause 11.

The mobile part is then directed to move down a glass surface inclined at 10° to the horizontal and its speed is again measured. The measured speed shall not exceed the speed initially measured by more than 10 %.

24 Components

24.201 Thermal cut-outs and protective electronic circuits incorporated in **automatic battery-powered cleaners** for compliance with 19.7 shall be non-self-resetting.

Compliance is checked by inspection.

30 Resistance to heat and fire

30.2 Addition:

For **automatic battery-powered cleaners**, 30.2.3 is applicable.

Annex C
(normative)

Ageing test on motors

Modification:

The value of p in Table C.1 is 2 000.

<http://www.china-gauges.com/>



Annex R (normative)

Software evaluation

R.2.2.5 *Modification:*

For programmable **electronic circuits** with functions requiring software incorporating measures to control the fault/error conditions specified in Table R.1 or Table R.2, detection of a fault/error shall occur before compliance with Clause 19 and 22.201 of Annex B is impaired.

R.2.2.9 *Modification:*

The software and safety-related hardware under its control shall be initialized and shall terminate before compliance with Clause 19 and 22.201 of Annex B is impaired.



Bibliography

The bibliography of Part 1 is applicable except as follows.

Addition:

IEC 60335-2-69, *Household and similar electrical appliances – Safety – Part 2-69: Particular requirements for wet and dry vacuum cleaners, including power brushes, for industrial and commercial use*

ISO 3864-1, *Graphical symbols – Safety colours and safety signs – Part 1: Design principles for safety signs in workplaces and public areas*

☐^{A1} Text deleted ☐^{A1}

<http://www.china-gauges.com/>

<http://www.china-gauges.com/>

British Standards Institution (BSI)

BSI is the national body responsible for preparing British Standards and other standards-related publications, information and services.

BSI is incorporated by Royal Charter. British Standards and other standardization products are published by BSI Standards Limited.

About us

We bring together business, industry, government, consumers, innovators and others to shape their combined experience and expertise into standards-based solutions.

The knowledge embodied in our standards has been carefully assembled in a dependable format and refined through our open consultation process. Organizations of all sizes and across all sectors choose standards to help them achieve their goals.

Information on standards

We can provide you with the knowledge that your organization needs to succeed. Find out more about British Standards by visiting our website at bsigroup.com/standards or contacting our Customer Services team or Knowledge Centre.

Buying standards

You can buy and download PDF versions of BSI publications, including British and adopted European and international standards, through our website at bsigroup.com/shop, where hard copies can also be purchased.

If you need international and foreign standards from other Standards Development Organizations, hard copies can be ordered from our Customer Services team.

Subscriptions

Our range of subscription services are designed to make using standards easier for you. For further information on our subscription products go to bsigroup.com/subscriptions.

With **British Standards Online (BSOL)** you'll have instant access to over 55,000 British and adopted European and international standards from your desktop. It's available 24/7 and is refreshed daily so you'll always be up to date.

You can keep in touch with standards developments and receive substantial discounts on the purchase price of standards, both in single copy and subscription format, by becoming a **BSI Subscribing Member**.

PLUS is an updating service exclusive to BSI Subscribing Members. You will automatically receive the latest hard copy of your standards when they're revised or replaced.

To find out more about becoming a BSI Subscribing Member and the benefits of membership, please visit bsigroup.com/shop.

With a **Multi-User Network Licence (MUNL)** you are able to host standards publications on your intranet. Licences can cover as few or as many users as you wish. With updates supplied as soon as they're available, you can be sure your documentation is current. For further information, email bsmusales@bsigroup.com.

BSI Group Headquarters

389 Chiswick High Road London W4 4AL UK

Revisions

Our British Standards and other publications are updated by amendment or revision.

We continually improve the quality of our products and services to benefit your business. If you find an inaccuracy or ambiguity within a British Standard or other BSI publication please inform the Knowledge Centre.

Copyright

All the data, software and documentation set out in all British Standards and other BSI publications are the property of and copyrighted by BSI, or some person or entity that owns copyright in the information used (such as the international standardization bodies) and has formally licensed such information to BSI for commercial publication and use. Except as permitted under the Copyright, Designs and Patents Act 1988 no extract may be reproduced, stored in a retrieval system or transmitted in any form or by any means – electronic, photocopying, recording or otherwise – without prior written permission from BSI. Details and advice can be obtained from the Copyright & Licensing Department.

Useful Contacts:

Customer Services

Tel: +44 845 086 9001

Email (orders): orders@bsigroup.com

Email (enquiries): cservices@bsigroup.com

Subscriptions

Tel: +44 845 086 9001

Email: subscriptions@bsigroup.com

Knowledge Centre

Tel: +44 20 8996 7004

Email: knowledgecentre@bsigroup.com

Copyright & Licensing

Tel: +44 20 8996 7070

Email: copyright@bsigroup.com